

March 2025

lindapter®

Established 1934



Technical Innovation in Steel Connections

Welcome

For over 90 years Lindapter has earned a respected reputation as the pioneer in the design and manufacture of steel clamping systems, growing from a modest family business into a reputable global brand by providing a faster, cost-effective alternative to drilling or welding.

History



Lindapter's proud heritage began in 1934 when Engineer Henry Lindsay (*above*) invented an entirely new concept of connecting steel with the Lindsay Bolt Adapter, a solution that allowed steel beams to be quickly clamped together, instead of time-consuming drilling or welding.

Henry combined the words 'Lindsay' and 'Adapter' to create the trusted brand name. Today Lindapter remains true to its roots, by continuing to invent and manufacture high quality, safe products that save steel contractors time and money.

Lindapter's unique connections can be installed with standard hand tools and allow faster construction, reduce labor costs and allow on-site adjustability with no damage to steel sections.

Here to help you

PAGES 6 - 7

Lindapter's team of experienced Engineers offer unrivalled support which includes free connection detailing and custom product development, from initial design through to installation guidance.



Girder Clamps

PAGES 8 - 43

High strength connections for steel beams, channels or angles. Type AF and AAF clamps have been evaluated by ICC-ES for structural connections in all Seismic Design Categories (A to F).



Lifting Points

PAGES 44 - 47

These assemblies support the lifting or rigging of general equipment. Can be used for single lift situations or permanent applications such as theater, lighting and rigging units.

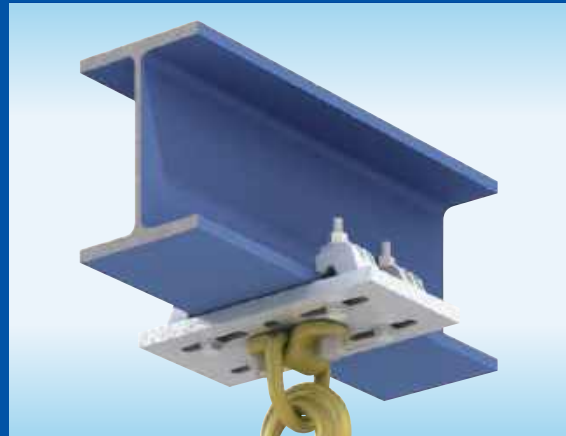

➤ Load values and typical Factors of Safety (FOS) shown in this catalog are for Lindapter products only and are subject to the strength of the supporting section. Tightening torques stated are for unlubricated fasteners.

Hollo-Bolt™

PAGES
48 - 65

Expansion bolts for quickly connecting steel sections to Hollow Structural Section (HSS) from one side. All Hollo-Bolts have been evaluated by ICC-ES for all Seismic Design Categories (A to F).



Steel Floor Connections

PAGES
66 - 69

A range of innovative products for connecting steel flooring to the supporting steel without the need for on-site drilling or welding. Installation can be carried out quickly and safely from above.

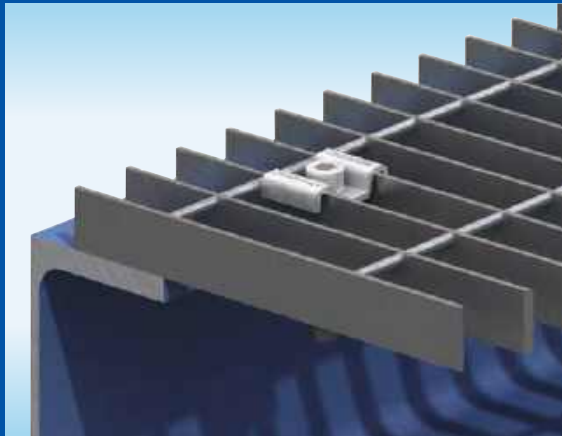

Pipe / Conduit Supports

PAGES
70 - 75

Easy-to-install solutions for suspending building services from structural or secondary beams. The adjustability of these products allows pipework and other equipment to be quickly positioned.



Case Studies

PAGES
86 - 93

Read how Lindapter's proven connection solutions have been used in prestigious construction projects such as the Tobin Bridge in Boston and the Wilshire Grand Center in Los Angeles.



PAGES
77 - 79

Frequently Asked Questions

PAGES
80 - 85

Structural Sections

PAGE
98

Approvals

Markets

We provide technical solutions that overcome engineering and construction challenges. Our Engineers and support teams add value to projects across the globe, proven from Antarctica to the Caribbean, creating safety and time-saving benefits in a vast range of markets including:

Building & Construction

- ✓ Architectural
- ✓ Arts / Entertainment / Staging
- ✓ Building Refurbishment & Renovation
- ✓ Façades & Cladding
- ✓ Modular & Offsite Construction
- ✓ Retail Centers
- ✓ Signage
- ✓ Stadiums / Arenas
- ✓ Steel Building Construction
- ✓ Theme Parks / Recreation
- ✓ Warehouse / Distribution Centers

Energy

- ✓ Nuclear
- ✓ Oil & Gas - Off Shore
- ✓ Oil & Gas - On Shore
- ✓ Power Generation (other)
- ✓ Renewable Energy

Industrial

- ✓ Automotive
- ✓ MEP / Building Services
- ✓ Chemical & Pharmaceutical
- ✓ Cranes & Crane Rail
- ✓ Food Processing
- ✓ General Manufacturing
- ✓ Gigafactory
- ✓ Machine Building
- ✓ Material Handling
- ✓ Mining
- ✓ Ship Building

Infrastructure

- ✓ Airports
- ✓ Bridge
- ✓ Data Centers
- ✓ Ports / Docks / Piers / Seawalls
- ✓ Foundations / Piling
- ✓ Rail
- ✓ Roads
- ✓ Towers / Monopoles / Pylons
- ✓ Water & Wastewater / Treatment

Project Case Studies can be found on pages 88-95



Architectural



Automotive



Stadiums / Arenas



Bridges



Renewable Energy

Project Case Studies can be found on pages 88-95



Modular & Offsite Construction



Steel Building Construction

Market Sector Brochures

In addition to this technical catalog, browse our range of brochures to find typical connection solutions for your market. Each brochure is packed with typical applications and product recommendations. Visit our website and create a free Lindapter account to access these resources.

Steel connection solutions for many industries and applications including:



Each brochure features a wide range of Lindapter connection solutions for specific market sectors, as well as real-life project photographs, descriptions of the solution and 3D renders so the reader can quickly understand and visualize the application and relate it to their own situation.

Extracts from the MEP Brochure pictured

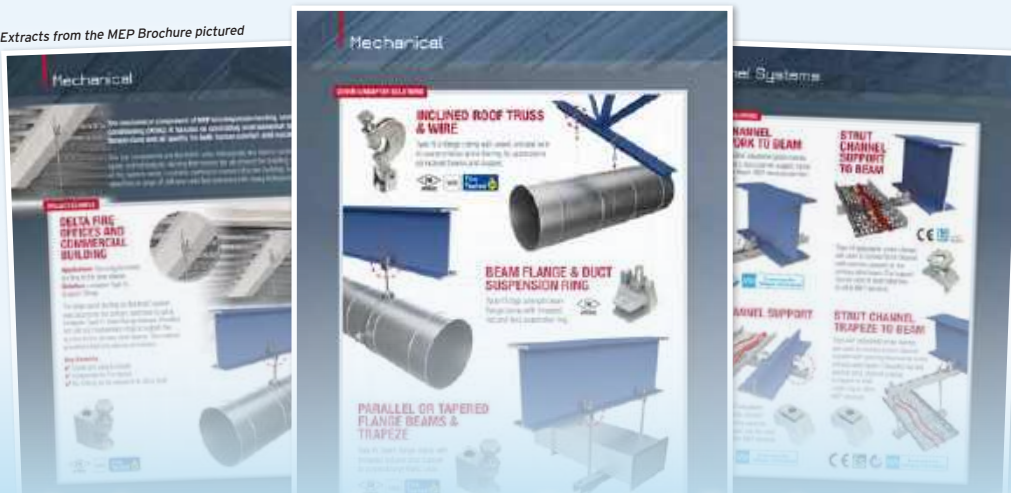

Download your copy from the 'Market Brochures' section at www.Lindapter.com

We are here to help

Lindapter's team of experienced Engineers offer an unrivalled support service, including free connection detail and custom product development. Lindapter's philosophy is to deliver the highest level of service from initial detail through to installation guidance.

Free connection detailing

Lindapter can design a custom connection based on your specific requirements free of charge in three easy steps. Based on your connection requirements, our Technical Support Engineers will supply customized CAD drawings and BIM compatible files to complement your structural designs.

Step 1

Email your requirement to
support@Lindapter.com

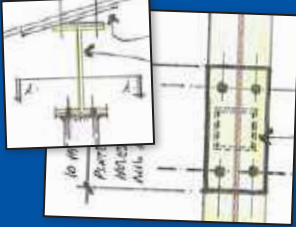

Step 2

Our experienced Engineers will
design your custom solution

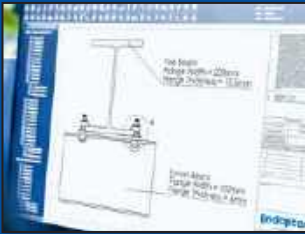

Step 3

An Engineer will send a detailed
connection drawing (see below)

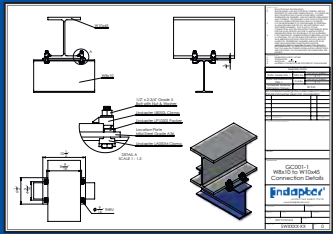

What we require...

If you would like Lindapter to design your custom connection, please make sure to have the following:

1. Member sizes to be used or flange width and thickness
2. Loads to be resisted (eg. 2,000lbs tension and 3,000lbs slip)
3. General arrangement sketch / verbal description
4. Project Name / Title / Location (optional)



The Design Sheet

Each submittal includes:

- A) Assembly Data (Design Strength and Allowable Strength or Safe Working Loads)
- B) Lindapter distributor purchasing information
- C) Customized project name or detail
- D) Your company name
- E) Lindapter product requirements
- F) Additional dimensions for precise fabrication

TO COMPLY WITH ICC-ES, PLEASE REFER TO EVALUATION REPORT No. ESR-3974 FOR REQUIRED BOLTING STANDARDS / TECHNICAL DATA & LINDAPTER SPECIAL INSPECTION DOCUMENT "SDGC" (ICC-ES REQUIRES CONNECTING STEELWORK TO BE BARE OR HOT DIP GALVANIZED (HDG) TO ASTM A153. OTHER COATINGS TO BE REMOVED LOCALLY)

SECTION A-A

Plate (ASTM A327 - Grade 50) - Bare or HDG

SECTION B-B

W27 x 84

W10 x 49

DETAIL C

Bolt & Nut to be tightened as shown in DIT instructions. (ASTM F959)

1/2" x 5" Grade A325 Bolt c/w Two Pin Hardened Washers, Heavy Hex Nut & DT Washer to suit (see section 3.2.2 of ESR 3974)

SECTION A-A		SECTION B-B		DETAIL C	
ITEM	DESCRIPTION	ITEM	DESCRIPTION	ITEM	DESCRIPTION
1	Plate (ASTM A327 - Grade 50) - Bare or HDG	1	W27 x 84	1	1/2" x 5" Grade A325 Bolt c/w Two Pin Hardened Washers, Heavy Hex Nut & DT Washer to suit (see section 3.2.2 of ESR 3974)
2	W10 x 49	2	W27 x 84	2	1/2" Dia. Drill Size

VALUES SHOWN IN TABLE ARE FOR THE FULL ASSEMBLY (four clamps combined) - ALL VALUES SUBJECT TO CAPACITY OF SECTIONS

ONLY TO BE USED BY ENGINEERS DESIGNING A CONNECTION AS PER AISC 341 AND AISC 358/3587 as referenced in section 2.0.5 of the BIC

A VALUES BELOW PER ESR-3974 ARE FOR THE CONNECTION AS SHOWN

ASSEMBLY	SECTION	DESIGN STRENGTH (k)	ALLOWABLE STRENGTH (k)	DESIGN STRENGTH (k)	ALLOWABLE STRENGTH (k)
1/2" A325	SECTION A-A	113.574	113.574	113.574	113.574

B LINDAPTER DISTRIBUTOR PURCHASING INFORMATION

C PROJECT NAME

D YOUR COMPANY NAME

E LINDAPTER PRODUCT REQUIREMENTS

F ADDITIONAL DIMENSIONS FOR PRECISE FABRICATION

Alternatively, try our **Girder Clamp Configurator** which produces fully detailed connection drawings to get an instant solution.



Additional technical support services available to you

We offer comprehensive design and support, tailoring our products to your application. Our team of qualified Structural and Mechanical Engineers are on hand to work with you to deliver the highest level of service from initial concept designs through to completion.

Engineered Solutions

Lindapter's Research & Development facility and unique expertise facilitates a custom product development service, passionately referred to as 'Engineered Solutions'. Supported by the latest technology including 3D modelling, 3D printing, FEA and three test machines with capacity of 5 to 200 tons, Lindapter's Engineers can develop solutions that satisfy your connection demands.

Key R&D Capabilities

- ✓ Creating initial concepts and 3D models, performing FEA stress analysis to validate designs
- ✓ 3D printed samples help verify the design before prototypes are made and tested
- ✓ In-house test facility with three machines with a capacity of 5 to 200 tons for static, tensile, compression shear and slip tests
- ✓ The team ensure products meet or exceed industry standards

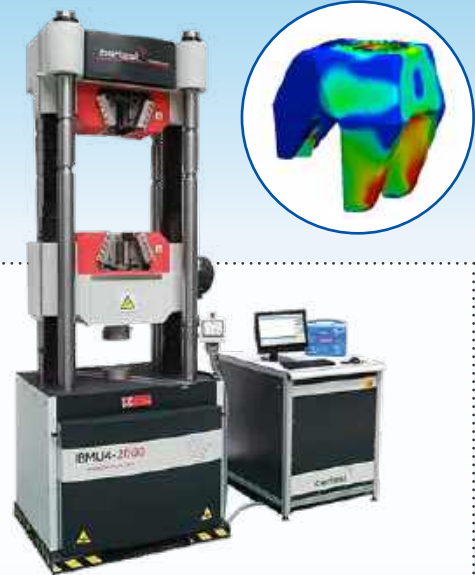

Contact Lindapter to design a solution for your connection requirement. Email support@Lindapter.com or call **866-566-2658 (BOLT)** for more details.

Lunch and Learn

We are pleased to offer Lunch and Learn presentations either in person or online and run regular live webinars. These presentations look at the unique solutions, offered by Lindapter, for connecting steel faster and more cost-effectively compared to alternative traditional methods of welding or drilling and bolting.



Who should attend?

Structural Engineers, Consulting Engineers and Specifiers involved with the design of steel-to-steel connections.

How do I book?

Please complete the Lunch and Learn form on the Lindapter website. Once we receive your request we will contact you to confirm the date and time. Webinars can be booked via our website Live Webinar Schedule news page.



Girder Clamp - The Connection Concept

Lindapter products provide a faster, cost-effective alternative to drilling or welding in the field and are designed to reduce installation time and labor costs. A high strength, permanent (or temporary) connection is quickly achieved by clamping two steel sections together.

Quick and easy to install

1) Bring the location plate and the lower beam into position below the upper beam.



2) Fit the bolts with two Lindapter clamps, any packings required, a nut and a washer.



3) Using a torque wrench, simply tighten each bolt to the recommended torque.



REASONS TO USE...



Save time and money

Clamping two steel sections together avoids time-consuming welding or conventional drilling and bolting.



High strength

Lindapter clamps are manufactured from high strength materials to resist high load requirements and harsh environments.



Adjustable

Quickly align steel sections by sliding the section into the correct position before tightening the Girder Clamp to complete the installation.



Safer connections

Drilling and welding in the field is avoided, removing the need for hot work permits and encouraging safer site conditions.



Industry leading approvals

Lindapter has earned a reputation synonymous with safety and reliability, gaining multiple independent approvals. Further details can be found on **page 98**.



Free connection detailing

Lindapter's experienced Engineers can detail a custom connection based on your specific requirements free of charge. See **page 6** for more details.

Turn to **page 10** to see the components of a Girder Clamp in more detail.



Watch how to install Girder Clamps at www.Lindapter.com



Typical Configurations

The Girder Clamp represents a range of Lindapter products that are compatible with virtually any shape or size of steel section and can withstand loading conditions in a wide variety of applications, for example:

STANDARD

Beam-to-beam (tensile loading)

The original configuration is designed to secure steel sections and resist tensile loading. It features a pre-drilled location plate that is placed between the beams to locate the four bolts. Each bolt has two Lindapter components to clamp the flange immediately above and below the plate. For larger beams with increased flange thicknesses, packing pieces may be required to raise the height of the clamp to ensure the component is positioned correctly on the beam.

See the components of a Girder Clamp in more detail on [page 10](#).



HIGH SLIP RESISTANCE

Beam-to-column (slip resistance)

This configuration utilizes a High Slip Resistance (HSR) clamp to achieve a secure connection to vertical columns.

An end plate is pre-fabricated to the section that will be joined to the column. The purpose of this plate is to locate the bolts and provide a fastening position for the Lindapter clamps.

Lindapter's range of HSR clamps can be found on [pages 12 - 25](#).

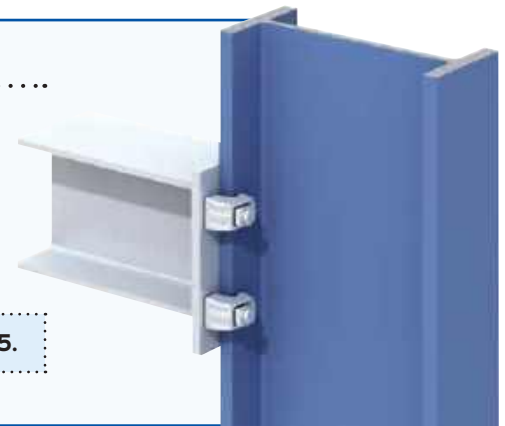

ADJUSTABLE

Inclined beam-to-beam (combined loading)

A fabricated assembly, optimized with Lindapter's adjustable High Slip Resistance clamps to resist both tensile loading and slip.

This solution is adjustable, allowing for a connection to a wide range of flange thicknesses for added convenience. Lindapter can detail and supply the entire assembly to suit individual applications.

Read more about free connection detailing on [page 6](#).



Lindapter has a solution for connecting almost any type of steel section including W beams, S beams, channels, angles and more. See [pages 39 - 43](#) for examples.

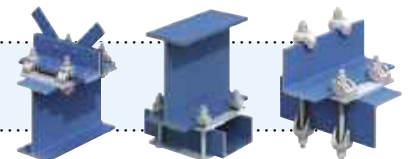

Girder Clamp Configuration

A Girder Clamp is a connection system configured with components to suit specific application requirements, for example high tensile loading or high corrosion resistance. Take advantage of our free connection detailing to find the best solution for your connection requirement.

Typical Girder Clamp Components

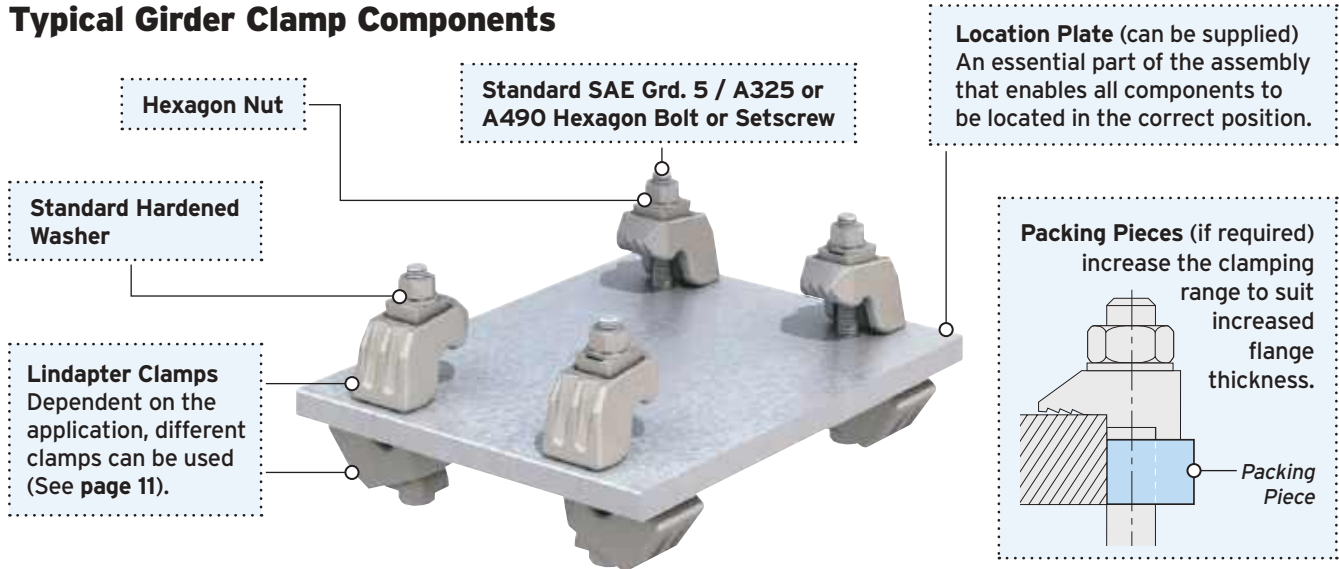

➤ This example is for illustration purposes only. Contact Lindapter to determine the optimum configuration for your connection requirement.

Bolt Length Calculator

To calculate bolt length, simply add up all parts the bolt will go through and use the next standard bolt length. The example on the right shows the Type AAF used with 1/2" A325 bolts to connect W12 x 26 below W14 x 61:

Can we help?
Try Lindapter's free connection detailing

For your next project, Lindapter's team of experienced Engineers can advise the correct product and detail the connection for you free of charge, providing CAD drawings in 2D or 3D BIM compatible files that can be imported into all major software. Turn to page 6 for more information.

A Bolt protrusion = 0.5 x bolt Ø	1/4"
B Height of nut	1/2"
C Hardened Washer	1/8"
D DTI Washer (if applicable)*	1/8"
E T of top clamp	1 3/8"
F Flange thickness of top section	5/8"
G Plate thickness	1/2"
H Flange thickness of lower section	3/8"
I T of lower clamp	1 3/8"
J Hardened Washer	1/8"
Total length	5 3/8"
Next standard bolt length	5 1/2"

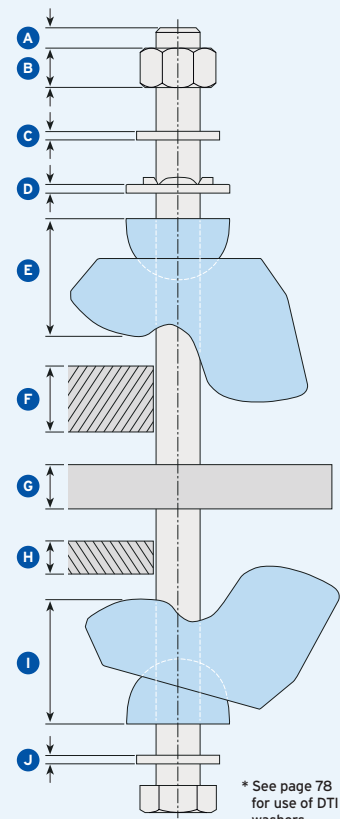

Product Configuration

The table below shows the various components that can be assembled in a Girder Clamp arrangement. Each product has specific properties, for example the Type AF heavy duty clamp can resist tensile loads up to 56,200lbs when used with four bolts (A490) in a Girder Clamp assembly.

Single Components

Product	Parallel Flanges	Tapered Flanges	Tensile	High Slip Resistance	Slotted Clearance Holes	Adjustable	Stainless Steel	Evaluated for Fatigue	Fire Tested per ASTM E-119	ICC-ES Approved
Type AAF pages 12-17 	✓	✓ ≤ 10°	✓	✓	✓	✓	-	✓	✓	✓ pages 14-15
Type AF pages 18-23 	✓	✓ ≤ 10°	✓	✓	✓	-	-	✓	✓	✓ pages 20-21
Type CF pages 24-25 	✓	✓ ≤ 10°	✓	✓	-	✓	-	-	-	
Type LR pages 26-27 	✓	✓ ≤ 15°	✓	-	✓	✓	-	-	-	
Type A pages 28-29 	✓	✓ ≤ 4°	✓	-	-	-	-	✓	-	
Type B pages 30-31 	✓	✓ ≤ 4°	✓	-	-	-	-	✓	-	
Type LS page 34-35 	✓	✓ ≤ 10°	✓	-	✓	✓	✓	-	-	
Type BR page 36 	✓	✓ ≤ 8°	✓	-	✓	-	-	-	-	

Other Clamp Systems (these products do not require a location plate)

Product	Parallel Flanges	Tapered Flanges	Tensile	High Slip Resistance	Slotted Clearance Holes	Adjustable	Stainless Steel
Type FC page 37 	✓	✓	✓	-	-	✓	-
Type F9 page 38 	✓	-	✓	-	-	✓	-

Also available

ICC-ES Approved Girder Clamps

See pages 14, 15, 20 & 21 for more information.



Lindapter Lifting Points

See pages 44 - 47 for more information.



Type AAF

This adjustable High Slip Resistance clamp is easy to install and provides high load capacities even in low temperature environments down to -76°F. Hot dip galvanized corrosion protection.



GIRDER CLAMPS

LIFTING POINTS

HOLLO-BOLT

FLOOR CONNECTIONS

PIPE SUPPORTS

FAQS & CASE STUDIES



- High slip resistance clamp evaluated for tensile, slip and combined load applications.
- Independently evaluated for fatigue resistance per ICC-ES ESR-3976, AISC 360 Appendix 3 and EN 1993-1-9.
- Self-adjusts to suit a range of flange thicknesses.
- Safe working loads apply in temperatures as low as -76°F.
- For parallel and tapered flanges up to and including 10°.
- The tail spans slotted clearance holes.

- Lindapter suggests the use of DTI Washers when using A325 or A490 structural bolts with Type AAF. For further information refer to page 78.
- For fatigue resistance please refer to ESR 3976 for appropriate stress category in accordance with AISC 360 Appendix 3 or contact our Technical Support team.

For Safe Working Loads or LRFD / ASD data turn to [page 13](#)

If you are designing a connection to the International Building Code refer to the ICC-ES data on [pages 14-15](#)

Watch the Type AAF installation video at www.Lindapter.com

LRFD / ASD Loads and Safe Working Loads for Type AAF



IMPORTANT: If you are designing a connection to the IBC, refer to the ICC-ES data on pages 14-15.

Material: Low temperature SG iron, hot dip galvanized.

Note: Y, X and T will vary depending on the thickness of V.

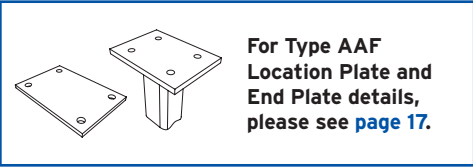
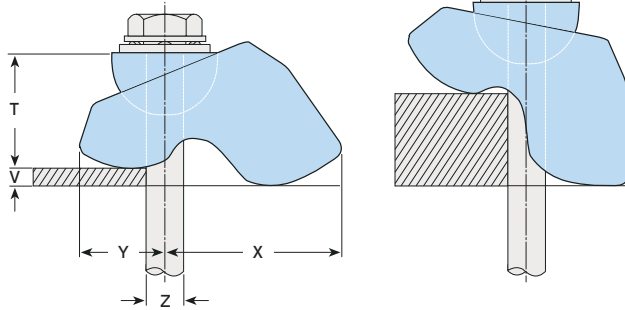

LRFD/ASD STATIC LOAD DATA (see page 15 for ICC Seismic load tables)															
Product Code	Bolt		Static Loads				Minimum Plate Thickness (see page 17)		Tight. Torque*	Clamping Range V	Dimensions				
	Size Z	Grade	LRFD Design Strength		ASD Allowable Strength		Location Plate	End Plate			Galv. Steel ft lb	Y	X	T	Width
			Tension 1/bolt lbs	Slip ³⁾ 2/bolts lbs	Tension 1/bolt lbs	Slip ³⁾ 2/bolts lbs									
LAAF050	1/2"	A325	6025	1350	3750	845	1/2"	1/2"	66	3/16" - 1"	1" - 15/16"	1 1/16" - 1 15/16"	1 1/32" - 1 3/8"	1 5/8"	
LAAF062	5/8"	A325	9100	2700	5700	1745	5/8"	3/4"	177	1/4" - 13/16"	1 5/16" - 2"	1 1/4" - 2 5/16"	1 3/8" - 1 13/16"	2 3/16"	
LAAF075	3/4"	A325	15300	4070	9575	2540	3/4"	1"	347	1/4" - 19/16"	1 5/16" - 2 1/2"	1 7/8" - 3 1/16"	2 1/16" - 2 1/2"	3"	
LAAF062	5/8"	A490**	9925	3150	6200	1965	5/8"	1"	221	1/4" - 13/16"	1 5/16" - 2"	1 1/4" - 2 5/16"	1 3/8" - 1 13/16"	2 3/16"	
LAAF075	3/4"	A490**	16850	6650	10525	4150	3/4"	1"	477	1/4" - 19/16"	1 5/16" - 2 1/2"	1 7/8" - 3 1/16"	2 1/16" - 2 1/2"	3"	

SAFE WORKING LOAD DATA														
Product Code	Bolt		Safe Working Loads				Minimum Plate Thickness (see page 17)		Tight. Torque*	Clamping Range V	Dimensions			
	Size Z	Grade	Tensile Resistance / 1 Bolt (FOS 4.5:1) lbs	Slip Resistance ¹⁾ / 2 Bolts (FOS 2:1)		Location Plate	End Plate	Galv. Steel ft lb			Y	X	T	Width
				Painted Steel ²⁾ lbs	Galv. Steel lbs									
LAAF050	1/2"	5/A325	1911	764	877	1/2"	1/2"	66	3/16" - 1"	1" - 15/16"	1 1/16" - 1 15/16"	1 1/32" - 1 3/8"	1 5/8"	
LAAF062	5/8"	5/A325	3597	1798	2248	5/8"	3/4"	177	1/4" - 13/16"	1 5/16" - 2"	1 1/4" - 2 5/16"	1 3/8" - 1 13/16"	2 3/16"	
LAAF075	3/4"	5/A325	5901	2922	3597	3/4"	1"	347	1/4" - 19/16"	1 5/16" - 2 1/2"	1 7/8" - 3 1/16"	2 1/16" - 2 1/2"	3"	
LAAF062	5/8"	A490**	4383	2473	2698	5/8"	1"	221	1/4" - 13/16"	1 5/16" - 2"	1 1/4" - 2 5/16"	1 3/8" - 1 13/16"	2 3/16"	
LAAF075	3/4"	A490**	6744	4496	5620	3/4"	1"	477	1/4" - 19/16"	1 5/16" - 2 1/2"	1 7/8" - 3 1/16"	2 1/16" - 2 1/2"	3"	

1) Slip resistant values calculated against movement exceeding 0.004" / 0.1mm.
 2) Shot blast and painted steel.
 3) Slip loads are calculated based on bare or galvanized steel.
 * Torque figures based on fasteners in an unlubricated condition. These values do not apply when using DTIs or Tension Control Bolts. For further information see page 78.
 ** Limited availability of Grade A490 bolts - please check availability before specifying.

GIRDER CLAMPS
LIFTING POINTS
HOLLO-BOLT
FLOOR CONNECTIONS
PIPE SUPPORTS
FAOS & CASE STUDIES

Type AAF (data for applications requiring ICC approval)

Lindapter's Girder Clamp is the world's first and only approved structural steel clamping system that is compliant with the International Building Code for structural and seismic designs. Extracts of ICC Evaluation Service Report ESR-3976 can be found below, visit www.Lindapter.com to view the full report.

		Evaluated for fatigue resistance per ICC-ES ESR-3976			
		Code Compliance	<input checked="" type="checkbox"/> IBC	<input checked="" type="checkbox"/> IRC	<input checked="" type="checkbox"/> LARC
		<input checked="" type="checkbox"/> CBC	<input checked="" type="checkbox"/> CRC	<input checked="" type="checkbox"/> LABC	<input checked="" type="checkbox"/> LARC

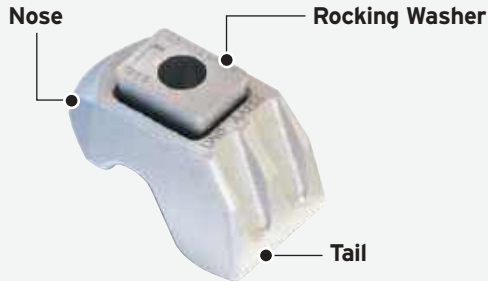

Note: Y, X and T will vary depending on the thickness of V.

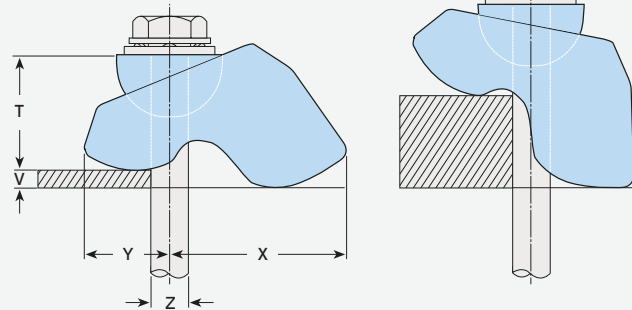

Material: Low temperature SG iron, hot dip galvanized.

DIMENSION DATA

Product Code	Bolt Size Z	Clamping Range V	Dimensions			
			Y	X	T	Width
LAAF050	1/2"	3/16" - 1"	1" - 1 5/16"	1 1/16" - 1 15/16"	1 1/32" - 1 3/8"	1 5/8"
LAAF062	5/8"	1/4" - 1 3/16"	1 5/16" - 2"	1 1/4" - 2 5/16"	1 3/8" - 1 13/16"	2 3/16"
LAAF075	3/4"	1/4" - 1 9/16"	1 15/16" - 2 1/2"	1 7/8" - 3 1/16"	2 1/16" - 2 1/2"	3"



Packing pieces are available to increase the clamping range, please see [page 16](#).

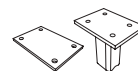

For Type AF Location Plate and End Plate details, please see [page 17](#).

ICC-ES Girder Clamp Components

The following components must be used for Type AAF ICC-ES approved connections:

- 1 Hexagon Nut to A563 Grade DH
- 2 Standard Hardened Washer to ASTM F436
- 3 DTI Washer to ASTM F959 (Required for A325 / A490 bolts per ICC, see page 78)
- 4 Type AAF
- 5 Location Plate or End Plate (see page 17)
- 6 Standard ASTM F3125 A325 / A490 Hexagon Bolt
If using a Tension Control Bolt (ASTM F1852/F2280), DTI washer is not required.

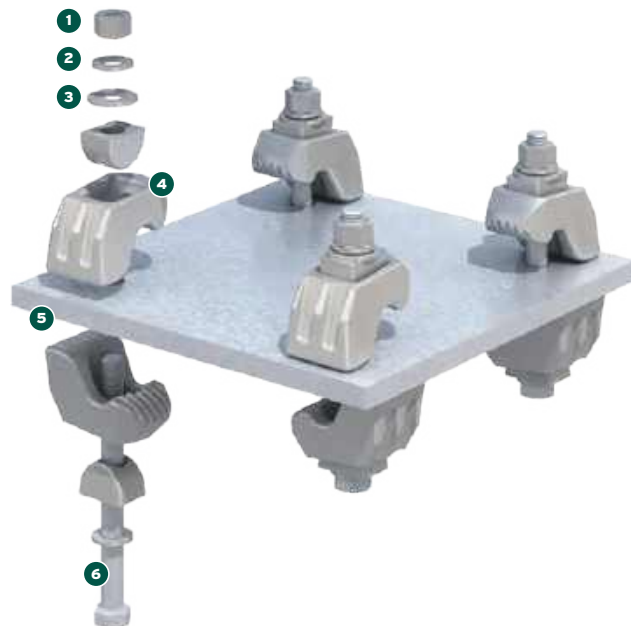

Type AAF (data for applications requiring ICC approval)

The data below is for use by Engineers designing a connection as per AISC 360, AISC 341 and ASCE / SEI 7 as referenced by the locally adopted building code. To comply with ICC-ES please also refer to Evaluation Report ESR-3976 and the Special Inspection Document which can be found on our website.

The Girder Clamp is approved for use in all Seismic Design Categories (SDC) A through F and can be configured with either a Location Plate or an End Plate (as shown in this example).

Design strengths are based on a four-bolt assembly and the correct data should be used for the required application. In this example, the LRFD design strength for an application in SDC A is shown.



GIRDER CLAMPS

LIFTING POINTS

HOLLOW-BOLT

FLOOR CONNECTIONS

PIPE SUPPORTS

FAOS & CASE STUDIES

Connection Example

Bolt Size	3/4"
Bolt Grade	A490
Design Method	LRFD
Seismic Design Category	A
Tensile Design Strength of Assembly	52,600 lbs
Slip Design Strength of Assembly	13,300 lbs

LRFD design strength & ASD allowable strength

LRFD and ASD strengths (taken from ESR-3976) are to be used when designing a connection per AISC 360, AISC 341 and ASCE/SEI 7 as referenced by the locally adopted building code. For combined loading refer to Evaluation Report ESR-3976.

Product Code	Bolt Size Grade		Static				Seismic Design Category A, B and C				Seismic Design Category D, E and F			
			LRFD Design Strength		ASD Allowable Strength		LRFD Design Strength		ASD Allowable Strength		LRFD Design Strength		ASD Allowable Strength	
			Tension /4 bolts lbs	Slip /4 bolts lbs	Tension /4 bolts lbs	Slip /4 bolts lbs	Tension /4 bolts lbs	Slip /4 bolts lbs	Tension /4 bolts lbs	Slip /4 bolts lbs	Tension /4 bolts lbs	Slip /4 bolts lbs	Tension /4 bolts lbs	Slip /4 bolts lbs
LAAF050	1/2"	A325	24100	2700	15000	1690	19500	2700	12200	1690	18200	2120	11400	1330
LAAF062	5/8"	A325	36400	5400	22800	3490	30200	5400	18900	3490	27200	4250	17000	2660
LAAF075	3/4"	A325	61200	8140	38300	5080	44600	8140	27900	5080	40600	8140	25400	5080
LAAF062	5/8"	A490	39700	6300	24800	3930	37200	6300	23300	3930	35600	5670	22300	3450
LAAF075	3/4"	A490	67400	13300	42100	8300	52600	13300	32900	8300	50800	11300	31800	7080

Notes: • A girder clamp connection includes multiples of two, typically four, replicate girder clamp assemblies.
 • Slip loads are calculated based on bare or galvanized steel. If using painted steel the coating must be removed at the point of contact to comply with ICC-ES ESR-3976.
 • Limited availability of Grade A490 bolts - please check availability before specifying.

- Refer to ESR-3976 and Lindapter's Special Inspection Document for details of connection design, installation and conditions of use.
- For fatigue resistance please refer to ESR 3976 for appropriate stress category in accordance with AISC 360 Appendix 3 or contact our Technical Support team.

Packing Pieces for Type AAF

Packing pieces are used to increase the clamping range to suit a range of flange thicknesses.

Packing Pieces

Type AFCW

Material: Mild steel, hot dip galvanized.



Product Code	Bolt Size Z	Dimension T
LAF050CW	1/2"	1/16"
LAF062CW	5/8"	1/16"

Note: Type AFCW has a slight bend along its center line which flattens out during installation.

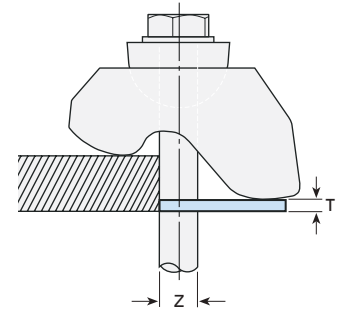

Type AFP1 / AFP2 / AAFP3

Material: Mild steel, hot dip galvanized.



Product Code	Bolt Size Z	Dimension T
LAF050P1	1/2"	3/16"
LAF062P1	5/8"	3/16"
LAF050P2	1/2"	3/8"
LAF062P2	5/8"	3/8"
LAAF075P3	3/4"	13/16"

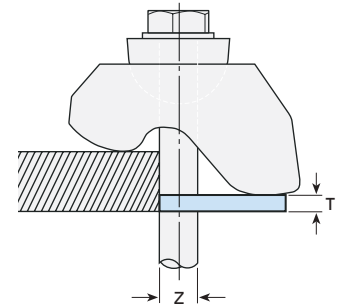

GIRDER CLAMPS

LIFTING POINTS

HOLLO-BOLT

FLOOR CONNECTIONS

PIPE SUPPORTS

FAQS & CASE STUDIES

Location and End Plates for Type AAF

These plates ensure the clamps and bolts are located in the correct position relative to the supporting steel. If you would like help choosing a suitable plate, please contact Lindapter.

Location Plate

Location plates are required when securing two sections together with clamps attached to the upper and lower sections with both clamps directly opposing each other.

The plate is positioned between the two sections to hold the bolts at the correct centers and should be fabricated to the dimensions shown in the table below.

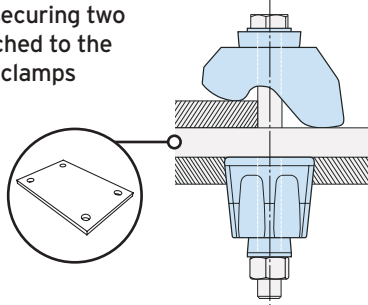

Material: Structural steel A572 Grade 50. For other grades contact Lindapter.

Bolt Size	Hole \emptyset d	Minimum Plate Thickness for Bolt Grade		Hole Centers C1	Length min L1	Hole Centers C2	Width min L2
		5/A325	A490				
1/2"	9/16"	1/2"	1/2"	$B_1 + 9/16"$	$B_1 + 4"$	$B_2 + 9/16"$	$B_2 + 4"$
5/8"	11/16"	5/8"	5/8"	$B_1 + 11/16"$	$B_1 + 4"$	$B_2 + 11/16"$	$B_2 + 4"$
3/4"	13/16"	3/4"	3/4"	$B_1 + 13/16"$	$B_1 + 6"$	$B_2 + 13/16"$	$B_2 + 6"$

LOCATION PLATE DIMENSIONS

L1 = Location Plate Length, L2 = Location Plate Width, B1, B2 = Flange Width, C1, C2 = Hole Centers, d = Hole \emptyset

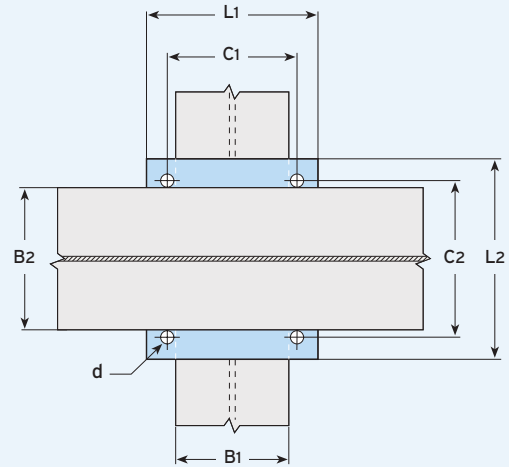

End Plate

End Plates should be used when clamps are attached to the supporting section only.

The End Plate holds the bolts at the correct centers and should be fabricated to the dimensions shown in the table below.

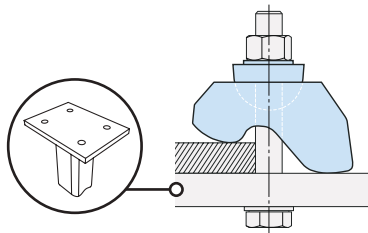

Material: Structural steel A572 Grade 50. For other grades contact Lindapter.

Bolt Size	Hole \emptyset d	Minimum Plate Thickness for Bolt Grade ¹⁾		Hole Centers C1	Length min L1	Hole Centers min C2	Width min L2
		5/A325	A490				
1/2"	9/16"	1/2"	5/8"	$B + 9/16"$	$B + 4"$	3"	$C_2 + 3"$
5/8"	11/16"	3/4"	1"	$B + 11/16"$	$B + 4"$	4"	$C_2 + 4"$
3/4"	13/16"	1"	1"	$B + 13/16"$	$B + 6"$	6"	$C_2 + 6"$

¹⁾ Depending on the type of connection and associated end plate use, the thickness may need to be modified to comply with accepted local design codes.

END PLATE DIMENSIONS

L1 = End Plate Length, L2 = End Plate Width, B = Flange Width, C1, C2 = Hole Centers, d = Hole \emptyset

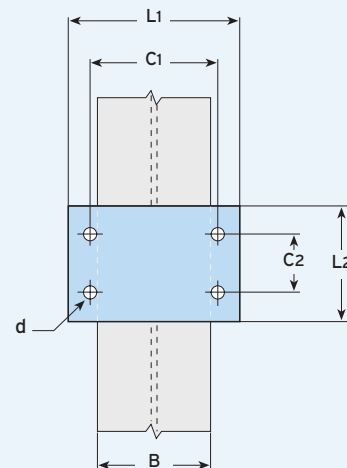

- For ICC-ES approved connections the Location Plate or End Plate must be bare steel or HDG. Refer to ESR-3976 and Lindapter's Special Inspection Document for details of connection design, installation and conditions of use.
- Use Lindapter's Bolt Length Calculator on page 10 to calculate the correct bolt length for your application.
- If drilling through the flange of the supported steel please contact Lindapter to ensure suitability.

Type AF

A heavy duty clamp offering the highest load capacities of all Lindapter's High Slip Resistance clamps. Hot dip galvanized corrosion protection.



Recess - holds bolt head captive
(Grd. 5 bolts, sizes 1/2" - 3/4" only)

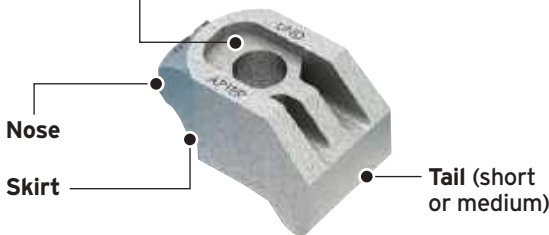

Type AF with Type AFW washer
(Type AFW supplied separately)

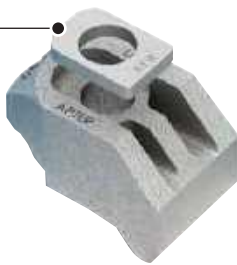

Note: Type AFW (page 22) converts the recess to a flat top and is required for A325, A490 and 1" Grade 5 structural bolts.

HIGH SLIP RESISTANCE

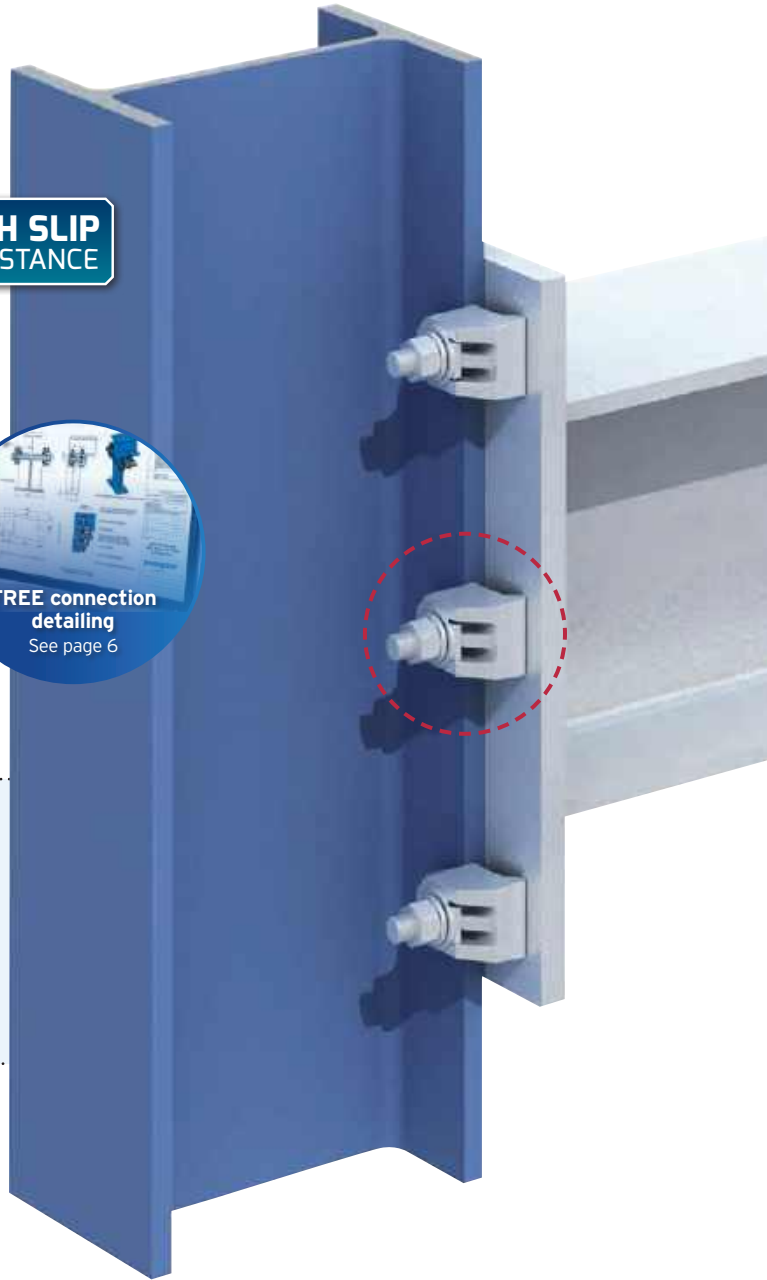
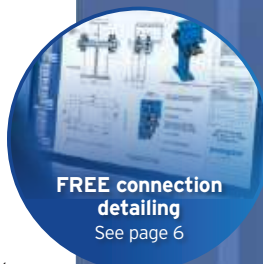

- High slip resistance clamp evaluated for tensile, slip and combined load applications.
- Static slip resistance of 15,736lbs or tensile 56,200lbs (4 x A490 bolt configuration, size 1").
- Independently evaluated for fatigue resistance per ICC-ES ESR-3976, AISC 360 Appendix 3 and EN 1993-1-9.
- For parallel and tapered flanges up to and including 10°.
- The tail spans slotted clearance holes.

- ▶ Lindapter suggests the use of DTI Washers when using A325 or A490 structural bolts with Type AF. For further information refer to page 78.
- ▶ For fatigue resistance please refer to ESR 3976 for appropriate stress category in accordance with AISC 360 Appendix 3 or contact our Technical Support team.

For Safe Working Loads or LRFD / ASD data turn to [page 19](#)

If you are designing a connection to the International Building Code refer to the ICC-ES data on [pages 20-21](#)

Watch the Type AF installation video at www.Lindapter.com

GIRDER CLAMPS

LIFTING POINTS

HOLLO-BOLT

FLOOR CONNECTIONS

PIPE SUPPORTS

FAQS & CASE STUDIES

LRFD / ASD Loads and Safe Working Loads for Type AF



IMPORTANT: If you are designing a connection to the IBC, refer to the ICC-ES data on pages 20-21.

Material: SG iron, hot dip galvanized.

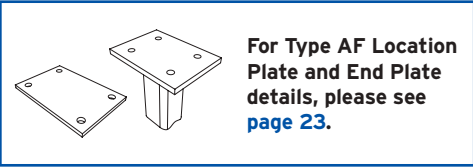
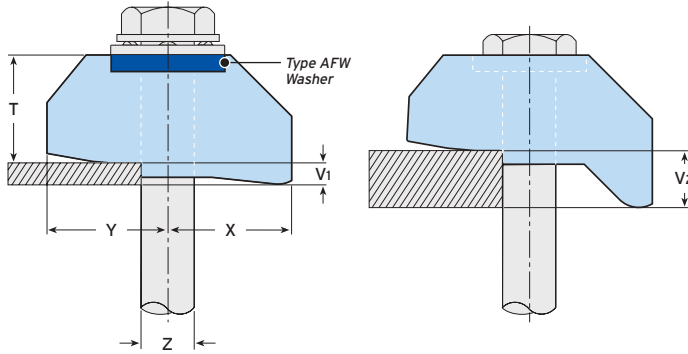

LRFD/ASD STATIC LOAD DATA (see page 21 for ICC Seismic load tables)

Product Code	Bolt		Static Loads				Minimum Plate Thickness (see page 23)		Tightening Torque* ft lb	Tail Length		Dimensions				
	Size Z	Grade	LRFD Design Strength		ASD Allowable Strength		Location Plate	End Plate		short V1	medium V2	Y	X	T		Width
			Tension 1/bolt lbs	Slip ⁴⁾ 2/bolts lbs	Tension 1/bolt lbs	Slip ⁴⁾ 2/bolts lbs								AF	AF + AFW	
LAF050	1/2"	A325	6025	1350	3750	845	1/2"	1/2"	66	3/16"	1/2"	1 1/8"	1 1/16"	1 1/16"	7/8"	1 9/16"
LAF062	5/8"	A325	9100	2700	5700	1745	5/8"	5/8"	177	5/16"	9/16"	1 3/8"	1 1/2"	7/8"	1 1/16"	1 15/16"
LAF075	3/4"	A325	15300	4070	9575	2540	3/4"	3/4"	347	3/8"	1 1/16"	1 9/16"	1 9/16"	1"	1 1/4"	2 3/16"
LAF100	1"	A325	25750	6350	16125	3980	1"	1"	590	9/16"	1 1/8"	1 7/8"	2 3/8"	1 1/4"	1 5/8"	3 1/4"
LAF062	5/8"	A490**	9925	3150	6200	1965	5/8"	3/4"	221	5/16"	9/16"	1 3/8"	1 1/2"	7/8"	1 1/16"	1 15/16"
LAF075	3/4"	A490**	16850	6650	10525	4150	3/4"	3/4"	477	3/8"	1 1/16"	1 9/16"	1 9/16"	1"	1 1/4"	2 3/16"
LAF100	1"	A490**	34250	9050	21425	5650	1"	1"	737	9/16"	1 1/8"	1 7/8"	2 3/8"	1 1/4"	1 5/8"	3 1/4"

SAFE WORKING LOAD DATA

Product Code	Bolt		Safe Working Loads			Minimum Plate Thickness (see page 23)		Tightening Torque* ft lb	Tail Length		Dimensions				
	Size Z	Grade	Tensile Resistance / 1 Bolt (FOS 5:1) lbs	Slip Resistance ¹⁾ / 2 Bolts (FOS 2:1)		Location Plate	End Plate		short V1	medium V2	Y	X	T		Width
				Painted Steel ²⁾ lbs	Galv. Steel lbs								AF	AF + AFW	
LAF050	1/2"	5 / A325	1911	764	877	1/2"	1/2"	66	3/16"	1/2"	1 1/8"	1 1/16"	1 1/16"	7/8"	1 9/16"
LAF062	5/8"	5 / A325	3597	1798	2248	5/8"	5/8"	177	5/16"	9/16"	1 3/8"	1 1/2"	7/8"	1 1/16"	1 15/16"
LAF075	3/4"	5 / A325	5901	2922	3597	3/4"	3/4"	347	3/8"	1 1/16"	1 9/16"	1 9/16"	1"	1 1/4"	2 3/16"
LAF100	1"	5 / A325	8892	5395	6774	1"	1"	590	9/16"	1 1/8"	1 7/8"	2 3/8"	1 1/4"	1 5/8"	3 1/4"
LAF062	5/8"	A490**	4383	2473	2698	5/8"	3/4"	221	5/16"	9/16"	1 3/8"	1 1/2"	7/8"	1 1/16"	1 15/16"
LAF075	3/4"	A490**	6744	4496	5620	3/4"	3/4"	477	3/8"	1 1/16"	1 9/16"	1 9/16"	1"	1 1/4"	2 3/16"
LAF100	1"	A490**	14050 ³⁾	6295	7868	1"	1"	737	9/16"	1 1/8"	1 7/8"	2 3/8"	1 1/4"	1 5/8"	3 1/4"

1) Slip resistant values calculated against movement exceeding 0.004" / 0.1mm.

2) Shot blast and painted steel.

3) 3.2:1 Factor of Safety.

4) Slip loads are calculated based on bare or galvanized steel.

* Torque figures based on fasteners in an unlubricated condition. These values do not apply when using DTIs or Tension Control Bolts. For further information see page 78.

** Limited availability of Grade A490 bolts - please check availability before specifying.

Type AF (data for applications requiring ICC approval)

Lindapter's Girder Clamp is approved for use in all Seismic Design Categories (A through F) and is the only structural steel clamping system compliant with the International Building Code. Extracts of ICC Evaluation Service Report ESR-3976 can be found below, visit www.Lindapter.com to view the full report.

		Evaluated for fatigue resistance per ICC-ES ESR-3976					
		Code Compliance	<input checked="" type="checkbox"/> IBC	<input checked="" type="checkbox"/> IRC	<input checked="" type="checkbox"/> LABC	<input checked="" type="checkbox"/> LARC	
<input checked="" type="checkbox"/> CBC	<input checked="" type="checkbox"/> CRC	<input checked="" type="checkbox"/> LABC	<input checked="" type="checkbox"/> LARC				

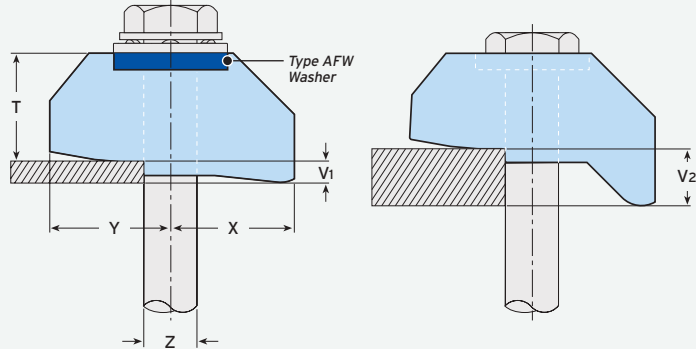

Material: SG iron, hot dip galvanized.

DIMENSION DATA							
Product Code	Bolt Size Z	Tail Length		Y	X	T	Width
		short V ₁	medium V ₂				
LAF050	1/2"	3/16"	1/2"	1 1/8"	1 1/16"	7/8"	19/16"
LAF062	5/8"	5/16"	9/16"	1 3/8"	1 1/2"	1 1/16"	1 15/16"
LAF075	3/4"	3/8"	1 1/16"	1 9/16"	1 9/16"	1 1/4"	2 3/16"
LAF100	1"	9/16"	1 1/8"	1 7/8"	2 3/8"	1 5/8"	3 1/4"

Packing pieces are available to increase the clamping range, please see [page 22](#).

For Type AF Location Plate and End Plate details, please see [page 23](#).

ICC-ES Girder Clamp Components

The following components must be used for Type AF ICC-ES approved connections:

- 1 Hexagon Nut to A563 Grade DH
- 2 Standard Hardened Washer to ASTM F436
- 3 DTI Washer to ASTM F959 (Required for A325 / A490 bolts per ICC, see page 78)
- 4 Type AFW Washer (see page 22)
- 5 Type AF
- 6 Location Plate or End Plate (see page 23)
- 7 Standard ASTM F3125 A325 / A490 Hexagon Bolt
If using a Tension Control Bolt (ASTM F1852/F2280), DTI washer is not required.

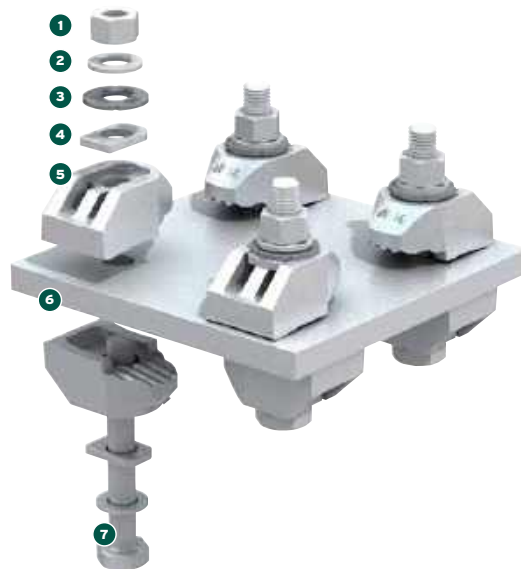

Type AF (data for applications requiring ICC approval)

The data below is for use by Engineers designing a connection as per AISC 360, AISC 341 and ASCE / SEI 7 as referenced by the locally adopted building code. To comply with ICC-ES please also refer to Evaluation Report ESR-3976 and the Special Inspection Document which can be found on our website.

The Girder Clamp is approved for use in all Seismic Design Categories (SDC) A through F and can be configured with either a Location Plate (as shown in this example) or an End Plate.

Design strengths are based on a four-bolt assembly and the correct data should be used for the required application. In this example, the LRFD design strength for an application in SDC F is shown.

Bare steel or HDG. —●
If coated remove locally at point of contact.

Example pictured: Location Plate configuration

Location Plate (Bare steel or HDG)

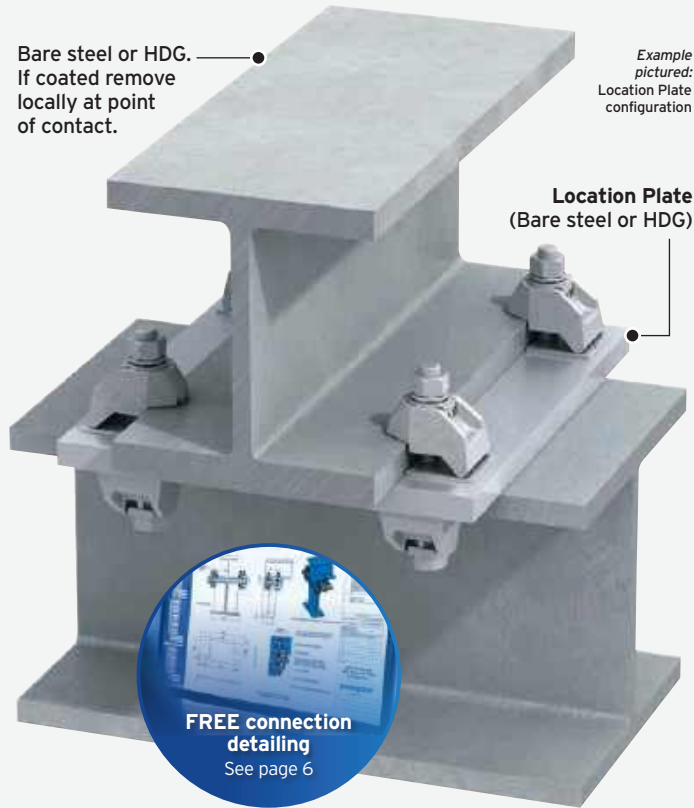

GIRDER CLAMPS

LIFTING POINTS

HOLLOW-BOLT

FLOOR CONNECTIONS

PIPE SUPPORTS

FAOS & CASE STUDIES

Connection Example

Bolt Size	1"
Bolt Grade	A490
Design Method	LRFD
Seismic Design Category	F
Tensile Design Strength of Assembly	116,000 lbs
Slip Design Strength of Assembly	18,100 lbs

FREE connection detailing
See page 6

LRFD design strength & ASD allowable strength

LRFD and ASD strengths (taken from ESR-3976) are to be used when designing a connection per AISC 360, AISC 341 and ASCE/SEI 7 as referenced by the locally adopted building code. For combined loading refer to Evaluation Report ESR-3976.

Product Code	Bolt Size Grade		Static				Seismic Design Category A, B and C				Seismic Design Category D, E and F			
			LRFD Design Strength		ASD Allowable Strength		LRFD Design Strength		ASD Allowable Strength		LRFD Design Strength		ASD Allowable Strength	
			Tension /4 bolts lbs	Slip /4 bolts lbs	Tension /4 bolts lbs	Slip /4 bolts lbs	Tension /4 bolts lbs	Slip /4 bolts lbs	Tension /4 bolts lbs	Slip /4 bolts lbs	Tension /4 bolts lbs	Slip /4 bolts lbs	Tension /4 bolts lbs	Slip /4 bolts lbs
LAF050	1/2"	A325	24100	2700	15000	1690	19500	2700	12200	1690	18200	2120	11400	1330
LAF062	5/8"	A325	36400	5400	22800	3490	30200	5400	18900	3490	27200	4250	17000	2660
LAF075	3/4"	A325	61200	8140	38300	5080	44600	8140	27900	5080	40600	8140	25400	5080
LAF100	1"	A325	103000	12700	64500	7960	86700	12700	54300	7960	80300	11700	50300	7310
LAF062	5/8"	A490	39700	6300	24800	3930	37200	6300	23300	3930	35600	5670	22300	3450
LAF075	3/4"	A490	67400	13300	42100	8300	52600	13300	32900	8300	50800	11300	31800	7080
LAF100	1"	A490	137000	18100	85700	11300	119000	18100	74400	11300	116000	18100	72800	11300

Notes: • A girder clamp connection includes multiples of two, typically four, replicate girder clamp assemblies.
• Slip loads are calculated based on bare or galvanized steel. If using painted steel the coating must be removed at the point of contact to comply with ICC-ES ESR-3976.
• Limited availability of Grade A490 bolts - please check availability before specifying.

- Refer to ESR-3976 and Lindapter's Special Inspection Document for details of connection design, installation and conditions of use.
- For fatigue resistance please refer to ESR 3976 for appropriate stress category in accordance with AISC 360 Appendix 3 or contact our Technical Support team.

Packing Pieces for Type AF

Packing pieces are used to increase the clamping range to suit a range of flange thicknesses. The Type AF is available with two different tail lengths (short and medium) and the correct combination of packing pieces should be used, see the table at the bottom of the page.

Packing Pieces

Type AFCW

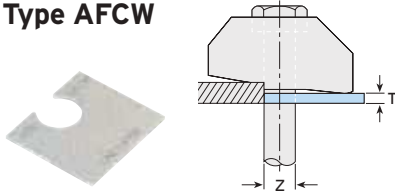

Material: Mild steel, hot dip galvanized.

Product Code	Bolt Size Z	Dimension T
LAF050CW	1/2"	1/16"
LAF062CW	5/8"	1/16"
LAF075CW	3/4"	1/16"

Note: Type AFCW has a slight bend along its center line which flattens out during installation.

Type AFP1 / AFP2 / AAFP3

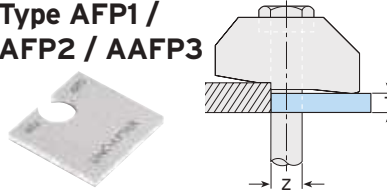

Material: Mild steel, hot dip galvanized.

Product Code	Bolt Size Z	Dimension T
LAF050P1	1/2"	3/16"
LAF062P1	5/8"	3/16"
LAF075P1	3/4"	3/16"
LAF100P1	1"	3/16"
LAF050P2	1/2"	3/8"
LAF062P2	5/8"	3/8"
LAF075P2	3/4"	3/8"
LAF100P2	1"	3/8"
LAAF075P3	3/4"	13/16"

Also Available

Type AFW

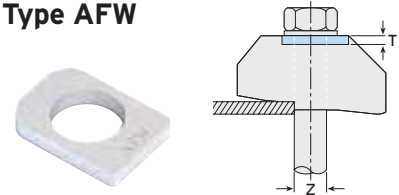

Material: SG iron, mild steel, hot dip galvanized.

Product Code	Bolt Size Z	Dimension T
LAF050W	1/2"	3/16"
LAF062W	5/8"	3/16"
LAF075W	3/4"	1/4"
LAF100W	1"	3/8"

Note: Type AFW converts the recess to a flat top to enable the bolt head or nut to be rotated on a hardened washer and is required for A325, A490 and 1" Grade 5 structural bolts.

Tail Length / Packing Piece Combinations for Type AF

Choose the correct combination for your configuration using the table on the right. Note these calculations are for parallel flanges and beams up to 10° slopes only. For example, a 3/4" Type AF on a 1 9/16" flange requires 1 x Type AF medium tail (M), 1 x Type AFCW and 2 x Type AFP2.

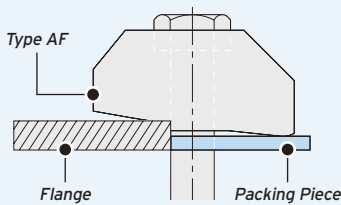

- For thicker flanges contact Lindapter.
- If your flange thickness exceeds the flange thickness listed in the table, use the packing piece combination from the next largest flange thickness. Interpolation of table values is not permitted.
- Other combinations than what is shown here may be possible. Please contact our Technical Support team to discuss your requirements.

Flange Thickness	1/2"				5/8"				3/4"				1"			
	AF	AFCW	AFP1	AFP2	AF	AFCW	AFP1	AFP2	AF	AFCW	AFP1	AFP2	AF	AFCW	AFP1	AFP2
3/16"	S	-	-	-	X	-	-	-	X	-	-	-	X	-	-	-
1/4"	S	-	-	-	X	-	-	-	X	-	-	-	X	-	-	-
5/16"	S	1	-	-	S	-	-	-	X	-	-	-	X	-	-	-
3/8"	S	-	1	-	S	1	-	-	S	-	-	-	X	-	-	-
7/16"	S	-	1	-	S	1	-	-	S	-	-	-	X	-	-	-
1/2"	M	-	-	-	S	-	1	-	S	1	-	-	S	-	-	-
9/16"	M	1	-	-	M	-	-	-	S	2	-	-	S	-	-	-
5/8"	S	-	-	1	M	-	-	-	S	-	1	-	S	-	-	-
11/16"	M	-	1	-	M	1	-	-	M	-	-	-	S	-	-	-
3/4"	S	2	-	1	M	2	-	-	M	-	-	-	S	-	1	-
13/16"	S	-	1	1	M	-	1	-	S	-	-	1	S	-	1	-
7/8"	M	-	-	1	M	1	1	-	M	2	-	-	S	-	1	-
15/16"	M	1	-	1	M	2	1	-	M	-	1	-	S	-	-	1
1"	S	-	-	2	M	-	-	1	M	1	1	-	S	-	-	1
1 1/16"	S	1	-	2	M	1	-	1	M	2	1	-	S	-	-	1
1 1/8"	M	3	-	1	S	-	-	2	M	-	-	1	S	-	-	1
1 3/16"	S	-	1	2	M	-	1	1	M	1	-	1	M	-	-	-
1 1/4"	S	1	1	2	M	1	1	1	M	2	-	1	M	-	-	-
1 5/16"	M	-	-	2	S	-	1	2	M	-	1	1	M	-	-	-
1 3/8"	S	-	-	3	M	-	-	2	M	1	1	1	M	-	1	-
1 7/16"	M	2	-	2	M	1	-	2	M	2	1	1	M	-	1	-
1 1/2"	M	-	1	2	S	-	-	3	M	-	-	2	M	-	-	1
1 9/16"	M	1	1	2	M	-	1	2	M	1	-	2	M	-	-	1
1 5/8"	M	2	1	2	M	1	1	2	M	1	-	2	M	-	-	1
1 11/16"	M	-	-	3	S	-	1	3	M	-	1	2	M	-	1	1
1 3/4"	M	1	-	3	M	2	1	2	M	1	1	2	M	-	1	1
1 13/16"	S	-	-	4	M	-	-	3	S	-	1	3	M	-	1	1
1 7/8"	S	1	-	4	M	1	-	3	M	-	-	3	M	-	1	1
1 15/16"	M	1	1	3	M	2	-	3	S	-	-	4	M	-	-	2
2"	S	-	1	4	M	-	1	3	S	-	-	4	M	-	-	2

AF = Type AF | AFCW = Type AFCW | AFP1 = Type AFP1 | AFP2 = Type AFP2 | S = AF short | M = AF medium | X = Not possible

Location and End Plates for Type AF

These plates ensure the clamps and bolts are located in the correct position relative to the supporting steel. If you would like help choosing a suitable plate, please contact Lindapter.

Location Plate

Location plates are required when securing two sections together with clamps attached to the upper and lower sections with both clamps directly opposing each other.

The plate is positioned between the two sections to hold the bolts at the correct centers and should be fabricated to the dimensions shown in the table below.

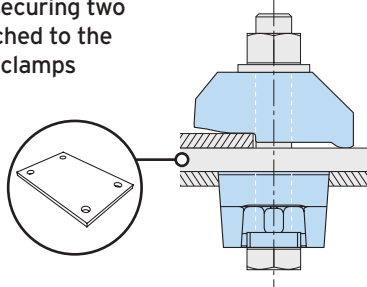

Material: Structural steel A572 Grade 50. For other grades contact Lindapter.

Bolt Size	Hole \emptyset d	Minimum Plate Thickness for Bolt Grade		Hole Centers C1	Length min L1	Hole Centers C2	Width min L2
		5/A325	A490				
1/2"	9/16"	1/2"	1/2"	$B_1 + 9/16"$	$B_1 + 4"$	$B_2 + 9/16"$	$B_2 + 4"$
5/8"	11/16"	5/8"	5/8"	$B_1 + 11/16"$	$B_1 + 4"$	$B_2 + 11/16"$	$B_2 + 4"$
3/4"	13/16"	3/4"	3/4"	$B_1 + 13/16"$	$B_1 + 5"$	$B_2 + 13/16"$	$B_2 + 5"$
1"	1 1/8"	1"	1"	$B_1 + 1 1/8"$	$B_1 + 7"$	$B_2 + 1 1/8"$	$B_2 + 7"$

LOCATION PLATE DIMENSIONS

L1 = Location Plate Length, L2 = Location Plate Width, B1, B2 = Flange Width, C1, C2 = Hole Centers, d = Hole \emptyset

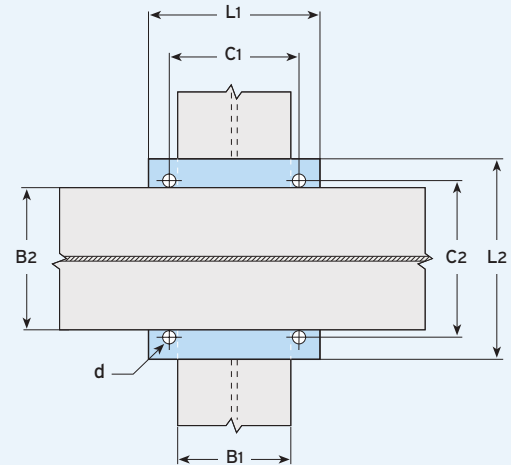

End Plate

End Plates should be used when clamps are attached to the supporting section only.

The End Plate holds the bolts at the correct centers and should be fabricated to the dimensions shown in the table below.

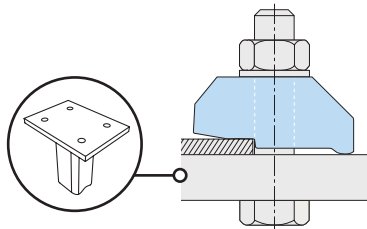

Material: Structural steel A572 Grade 50. For other grades contact Lindapter.

Bolt Size	Hole \emptyset d	Minimum Plate Thickness for Bolt Grade ¹⁾		Hole Centers C1	Length min L1	Hole Centers min C2	Width min L2
		5/A325	A490				
1/2"	9/16"	1/2"	1/2"	$B + 9/16"$	$B + 3"$	3"	$C_2 + 3"$
5/8"	11/16"	5/8"	3/4"	$B + 11/16"$	$B + 4"$	4"	$C_2 + 4"$
3/4"	13/16"	3/4"	3/4"	$B + 13/16"$	$B + 6"$	6"	$C_2 + 6"$
1"	1 1/8"	1"	1"	$B + 1 1/8"$	$B + 7 1/2"$	$7 1/2"$	$C_2 + 7 1/2"$

¹⁾ Depending on the type of connection and associated end plate use, the thickness may need to be modified to comply with accepted local design codes.

END PLATE DIMENSIONS

L1 = End Plate Length, L2 = End Plate Width, B = Flange Width, C1, C2 = Hole Centers, d = Hole \emptyset

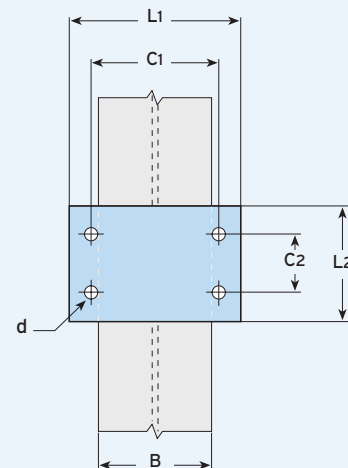

- For ICC-ES approved connections the Location Plate or End Plate must be bare steel or HDG. Refer to ESR-3976 and Lindapter's Special Inspection Document for details of connection design, installation and conditions of use.
- Use Lindapter's Bolt Length Calculator on page 10 to calculate the correct bolt length for your application.
- If drilling through the flange of the supported steel please contact Lindapter to ensure suitability.

Type CF

Hooks over the flanges of beams, angles and channels to connect steel sections that do not face, such as connecting horizontal beams with vertical columns.

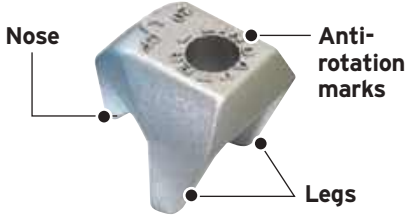

'V' refers to the thickness of the section at the edge of the profile where the component is in contact with the flange. This dimension should be checked when connecting to tapered flanges or sections with a radius on the flange edge.
 Note: The (t_p) value for C-Channels shown in AISC tables refer to the Average Thickness and not the edge thickness.

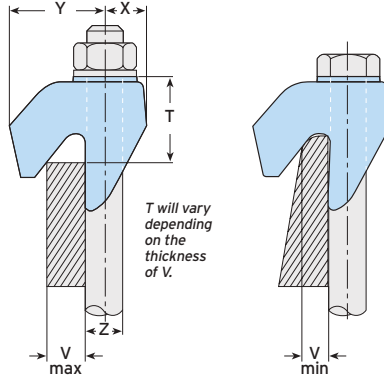

HIGH SLIP RESISTANCE

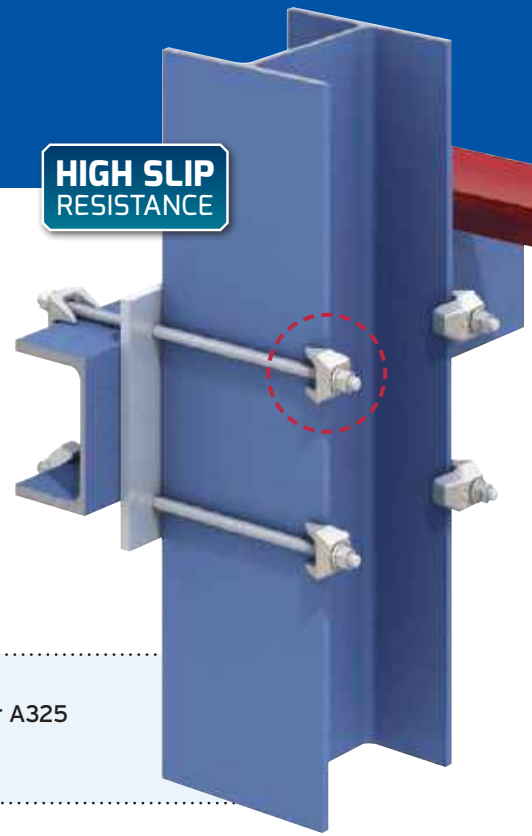

- Suitable for parallel and tapered flanges up to and including 10°.
- Can be combined with other Lindapter High Slip Resistance clamps (Grd. 5 or A325 bolts only); see table below for safe working loads.
- Can also be used with Grd. B7 or A449 rods.

Material: SG iron, hot dip galvanized.

Product Code	Bolt Grd. 5 / A325 Z	Safe Working Loads			Minimum Plate Thickness (for combinations with other Lindapter products see note below)		Tightening Torque* ft lb	Clamping Range V	Dimensions			Width
		Tensile Resistance / 1 Bolt (FOS 5:1) lbs	Slip Resistance ¹⁾ / 2 Bolts (FOS 2:1)		Location Plate	End Plate			Y	X	T	
LCF050	1/2"	1911	764	877	1/2"	1/2"	66	1/4" - 1/2"	1 1/4"	9/16"	13/16" - 1 1/8"	13/16"
LCF2050	1/2"	1911	764	877	1/2"	1/2"	66	1/2" - 3/4"	1 9/16"	5/8"	1 1/8" - 1 1/2"	1 7/8"
LCF062	5/8"	3597	1798	2248	5/8"	5/8"	177	5/16" - 5/8"	1 3/4"	1 1/16"	1" - 1 1/4"	2 3/16"
LCF2062	5/8"	3597	1798	2248	5/8"	5/8"	177	5/8" - 1"	2"	13/16"	1 3/8" - 1 7/8"	2 7/16"
LCF075	3/4"	5901	2922	3597	3/4"	3/4"	347	3/8" - 3/4"	2 1/16"	7/8"	1 3/16" - 1 9/16"	2 9/16"
LCF2075	3/4"	5901	2922	3597	3/4"	3/4"	347	3/4" - 13/16"	2 1/2"	1 1/16"	1 5/8" - 2 3/16"	2 3/4"

Type CF combinations with other Lindapter clamps (see note below)	Bolt	Tensile Resistance	Slip Resistance (Painted Steel)	Slip Resistance (Galv. Steel)	Location Plate	End Plate	Tightening Torque
CF + A ³⁾	1/2"	1304	202	202	3/8"	1/2"	50
CF + A ³⁾	5/8"	1911	382	382	3/8"	5/8"	108
CF + A ³⁾	3/4"	3305	674	674	1/2"	7/8"	210
CF + AF	1/2"	1911	764	877	1/2"	1/2"	66
CF + AF	5/8"	3597	1798	2248	5/8"	5/8"	177
CF + AF	3/4"	5901	2922	3597	3/4"	3/4"	347
CF + AAF	1/2"	1911	764	877	1/2"	1/2"	66
CF + AAF	5/8"	3597	1798	2248	5/8"	3/4"	177
CF + AAF	3/4"	5901	2922	3597	3/4"	1"	347

1) Slip resistant values calculated against movement exceeding 0.004" / 0.1mm.
 2) Shot blast and painted steel.
 3) Also applies to Type B, Type LR and Type BR.
 * Torque figures based on fasteners in an unlubricated condition. These values do not apply when using DTIs or Tension Control Bolts. For further information see page 78.

▶ Lindapter suggests the use of DTI Washers when using A325 structural bolts with Type CF. For further information refer to page 78.

When combining Type CF with other Lindapter products please refer to the relevant Location and End Plate details for those products. For Type AAF, see page 17. For Type AF, see page 23. For Type LR, see page 27. For Types A, B or BR see page 33.

Watch the Type CF installation video at www.Lindapter.com

Location and End Plates for Type CF

These plates ensure the clamps and bolts are located in the correct position relative to the supporting steel. If you would like help choosing a suitable plate, please contact Lindapter.

LOCATION AND END PLATE DIMENSIONS

B, B₁, B₂ = Flange Width C₁, C₂ = Hole Centers L₁ = Plate Length L₂ = Plate Width d = Hole Ø

Location Plates are required when securing two sections together with clamps attached to the upper and lower sections with both clamps directly opposing each other.

The plate is positioned between the two sections to hold the bolts at the correct centers and should be fabricated to the dimensions shown in the table below.

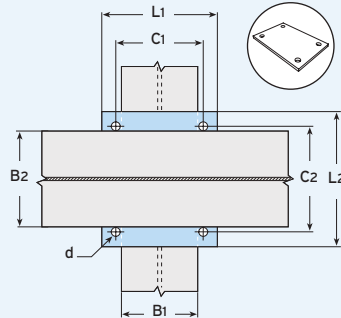

End Plates should be used when clamps are attached to the supporting section only.

The End Plate holds the bolts at the correct centers and should be fabricated to the dimensions shown in the table below.

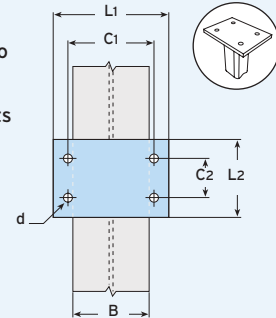

Structural steel grade A572 Grd. 50. For other grades contact Lindapter.

Bolt Size	Hole Ø	LOCATION PLATE (for Type CF only)					END PLATE (for Type CF only)				
		Minimum Plate Thickness for Bolt Grade 5/A325	Hole Centers C ₁	Length min L ₁	Hole Centers C ₂	Width min L ₂	Minimum Plate Thickness for Bolt Grade 5/A325 ¹⁾	Hole Centers C ₁	Length min L ₁	Hole Centers C ₂	Width min L ₂
1/2"	9/16"	1/2"	B ₁ + 9/16"	B ₁ + 3"	B ₂ + 9/16"	B ₂ + 3"	1/2"	B + 9/16"	B + 3"	3"	C ₂ + 3"
5/8"	11/16"	5/8"	B ₁ + 11/16"	B ₁ + 4"	B ₂ + 11/16"	B ₂ + 4"	5/8"	B + 11/16"	B + 4"	4"	C ₂ + 4"
3/4"	13/16"	3/4"	B ₁ + 13/16"	B ₁ + 6"	B ₂ + 13/16"	B ₂ + 6"	3/4"	B + 13/16"	B + 6"	6"	C ₂ + 6"

¹⁾ Depending on the type of connection and associated end plate use, the thickness may need to be modified to comply with accepted local design codes.

- When combining Type CF with other Lindapter products please refer to the relevant Location and End Plate details for those products. For Type AAF, see page 17. For Type AF, see page 23. For Type LR, see page 27. For Types A, B or BR see page 33.
- Use Lindapter's Bolt Length Calculator on page 10 to calculate the correct bolt length for your application.
- If drilling through the flange of the supported steel please contact Lindapter to ensure suitability.

Additional Applications

Type CF is a versatile solution that has been tested in a wide range of applications, including suspending equipment from supporting sections. It can be easily adjusted for quick alignment of pipework, electrical cables and other building services equipment. Two popular connection arrangements are shown below.

Example 1

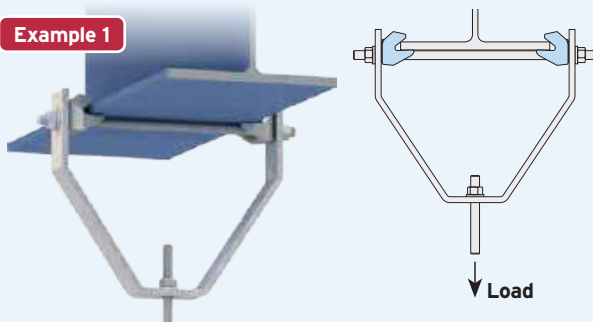

Bolt Size	Product Code(s)	Recommended Safe Working Load / bolt (FOS 5:1)
1/2"	LCF050 / LCF2050	1125 lbs
5/8"	LCF062 / LCF2062	2250 lbs
3/4"	LCF075 / LCF2075	4500 lbs

Example 2

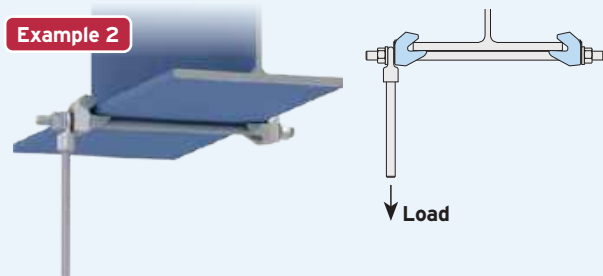

Bolt Size	Product Code(s)	Recommended Safe Working Load / bolt (FOS 5:1)
1/2"	LCF050 / LCF2050	225 lbs
5/8"	LCF062 / LCF2062	1350 lbs
3/4"	LCF075 / LCF2075	2700 lbs

Type LR

A versatile, self-adjusting clamp designed to suit a range of flange thicknesses.

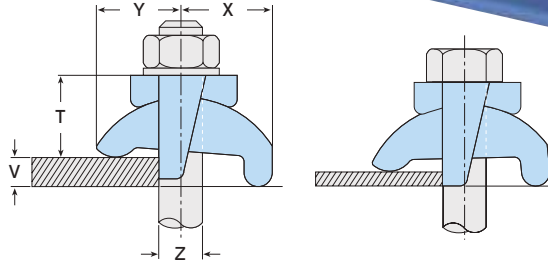
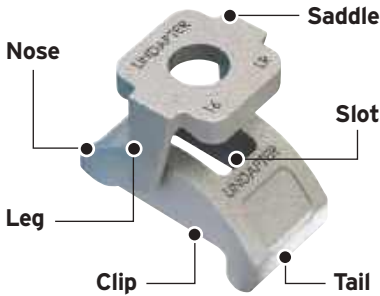

Note 1: When installing, ensure the straight (not tapered) leg of the saddle is in contact with the flange. Note 2: Y, X and T will vary depending on the thickness of V.

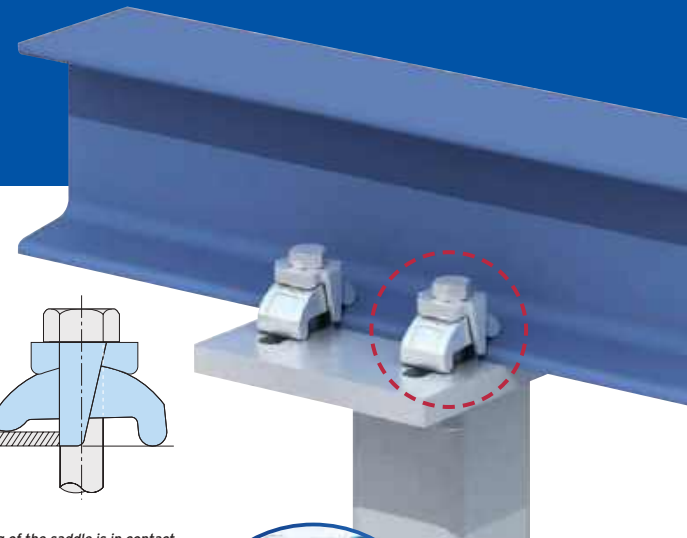

- Clamping ranges from 1/8" - 1" (size 1").
- For parallel and tapered flanges up to and including 15°.
- The leg of the saddle prevents the clamp from rotating.
- The tail spans slotted clearance holes.
- For higher loads the Type AAF should be used, see pages 12-13.

Watch the installation video at www.Lindapter.com

Material: Malleable iron, zinc plated or hot dip galvanized.

LRFD / ASD STATIC LOAD DATA

Product Code	Bolt Grd. 5 / A325 Z	Static Loads				Minimum Plate Thickness (see page 27)	Tight. Torque* ft lb	Clamping Range V	Dimensions			Width with Saddle
		LRFD Design Strength		ASD Allowable Strength					Y	X	T	
		Tension / 1 Bolt lbs	Slip / 2 Bolts lbs	Tension / 1 Bolt lbs	Slip / 2 Bolts lbs							
LLR037 ¹⁾	3/8"	1800	-	1125	-	5/16"	15	1/8" - 3/8"	13/16" - 15/16"	15/16" - 1"	13/16" - 15/16"	15/16"
LLR050	1/2"	3794	434	2383	271	1/2"	50	1/8" - 1/2"	1" - 1 1/8"	1" - 1 1/4"	1" - 1 1/8"	1 9/16"
LLR062	5/8"	5135	644	3209	403	5/8"	108	1/8" - 5/8"	1 3/16" - 1 3/8"	1 5/16" - 1 7/16"	1 3/16" - 1 7/16"	1 13/16"
LLR075	3/4"	8529	1669	5330	1043	3/4"	210	1/8" - 3/4"	1 5/8" - 1 15/16"	1 13/16" - 2"	1 5/8" - 1 7/8"	2 1/4"
LLR100	1"	10455	1965	6534	1228	3/4"	362	1/8" - 1"	1 7/8" - 2 1/4"	2 1/16" - 2 1/4"	1 3/4" - 2 1/8"	3"

SAFE WORKING LOAD DATA

Product Code	Bolt Grd. 5 / A325 Z	Safe Working Loads			Minimum Plate Thickness (see page 27)	Tightening Torque* ft lb	Clamping Range V	Dimensions			Width with Saddle
		Tensile Resistance / 1 Bolt (FOS 5:1) lbs	Slip Resistance / 2 Bolts (FOS 5:1) lbs					Y	X	T	
LLR037 ¹⁾	3/8"	337	-	5/16"	15	1/8" - 3/8"	13/16" - 15/16"	15/16" - 1"	13/16" - 15/16"	15/16"	
LLR050	1/2"	1304	202	1/2"	50	1/8" - 1/2"	1" - 1 1/8"	1" - 1 1/4"	1" - 1 1/8"	1 9/16"	
LLR062	5/8"	1911	382	5/8"	108	1/8" - 5/8"	1 3/16" - 1 3/8"	1 5/16" - 1 7/16"	1 3/16" - 1 7/16"	1 13/16"	
LLR075	3/4"	3305	674	3/4"	210	1/8" - 3/4"	1 5/8" - 1 15/16"	1 13/16" - 2"	1 5/8" - 1 7/8"	2 1/4"	
LLR100	1"	4430	1012	3/4"	362	1/8" - 1"	1 7/8" - 2 1/4"	2 1/16" - 2 1/4"	1 3/4" - 2 1/8"	3"	

¹⁾ LLR037 available in Hot Dip Galvanized only.

* Torque figures based on fasteners in an unlubricated condition. For further information see page 78.



Packing pieces are available to increase the clamping range, please see [page 27](#).



For Type LR Location Plate and End Plate details, please see [page 27](#).

GIRDER CLAMPS

LIFTING POINTS

HOLLO-BOLT

FLOOR CONNECTIONS

PIPE SUPPORTS

FAQS & CASE STUDIES

Packing Pieces and Plate details for Type LR

Packing pieces are available to increase the clamping range of the Type LR, please select the correct packing combination from the table below. This page also contains information for designing location and end plates.

Packing Pieces

Type P1 long /
Type P2 long

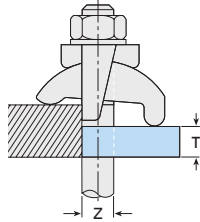

Mild steel, malleable iron, zinc plated or hot dip galvanized.

Product Code	Bolt Size Z	Dimension T
LP1037L	3/8"	3/16"
LP1050L	1/2"	1/4"
LP1062L	5/8"	5/16"
LP1075L	3/4"	3/8"
LP1100L	1"	1/2"
LP2037L	3/8"	3/8"
LP2050L	1/2"	1/2"
LP2062L	5/8"	5/8"
LP2075L	3/4"	3/4"
LP2100L	1"	1"

Tail Length / Packing Piece Combinations for Type LR

- For thicker flanges contact Lindapter.
- If your flange thickness exceeds the flange thickness listed in the table, use the packing piece combination from the next largest flange thickness. Interpolation of table values is not permitted.
- Other combinations than what is shown here may be possible. Contact our Technical Support team to discuss your requirements.

Flange Thickness	3/8"		1/2"		5/8"		3/4"		1"	
	P1L	P2L	P1L	P2L	P1L	P2L	P1L	P2L	P1L	P2L
3/16"	-	-	-	-	-	-	-	-	-	-
1/4"	-	-	-	-	-	-	-	-	-	-
5/16"	-	-	-	-	-	-	-	-	-	-
3/8"	-	-	-	-	-	-	-	-	-	-
7/16"	1	-	-	-	-	-	-	-	-	-
1/2"	1	-	-	-	-	-	-	-	-	-
9/16"	1	-	1	-	-	-	-	-	-	-
5/8"	-	1	1	-	-	-	-	-	-	-
11/16"	-	1	1	-	1	-	-	-	-	-
3/4"	-	1	-	1	1	-	-	-	-	-
13/16"	1	1	-	1	1	-	1	-	-	-
7/8"	1	1	-	1	1	-	1	-	-	-
15/16"	1	1	-	1	1	-	1	-	-	-
1"	1	1	1	1	-	1	1	-	-	-
1 1/16"	-	2	1	1	-	1	1	-	1	-
1 1/8"	-	2	1	1	-	1	1	-	1	-
1 3/16"	-	2	1	1	-	1	-	1	1	-
1 1/4"	1	2	-	2	-	1	-	1	1	-

P1L = Type P1 long | P2L = Type P2 long

LOCATION AND END PLATE DIMENSIONS

B, B1, B2 = Flange Width C1, C2 = Hole Centers L1 = Plate Length L2 = Plate Width d = Hole Ø

Location Plates are required when securing two sections together with clamps attached to the upper and lower sections with both clamps directly opposing each other.

The plate is positioned between the two sections to hold the bolts at the correct centers and should be fabricated to the dimensions shown in the table below.

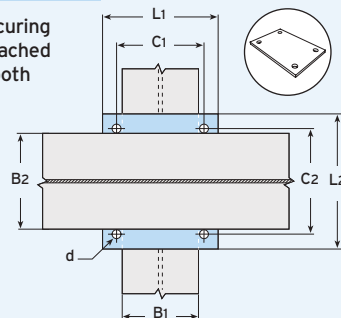
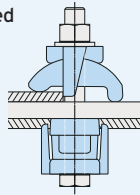

End Plates should be used when clamps are attached to the supporting section only. The End Plate holds the bolts at the correct centers and should be fabricated to the dimensions shown in the table below.

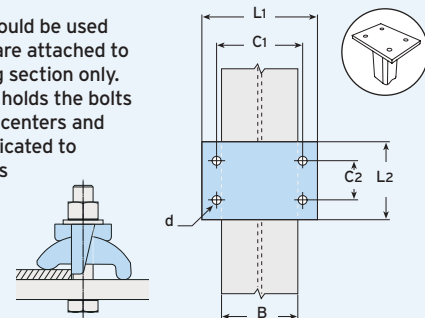

Structural steel grade A572 Grd. 50.
For other grades contact Lindapter.

Bolt Size	Hole Ø d	Plate Thickness ¹⁾
3/8"	7/16"	5/16"
1/2"	9/16"	1/2"
5/8"	11/16"	5/8"
3/4"	13/16"	3/4"
1"	1 1/16"	3/4"

LOCATION PLATE			
Hole Centers C1	Length min L1	Hole Centers C2	Width min L2
B1 + 7/16"	B1 + 2 5/8"	B2 + 7/16"	B2 + 2 5/8"
B1 + 9/16"	B1 + 3 3/8"	B2 + 9/16"	B2 + 3 3/8"
B1 + 11/16"	B1 + 4 1/8"	B2 + 11/16"	B2 + 4 1/8"
B1 + 13/16"	B1 + 4 7/8"	B2 + 13/16"	B2 + 4 7/8"
B1 + 1 1/8"	B1 + 6 3/4"	B2 + 1 1/8"	B2 + 6 3/4"

END PLATE			
Hole Centers C1	Length min L1	Hole Centers min C2	Width min L2
B + 7/16"	B + 2 5/8"	2 3/4"	C2 + 2"
B + 9/16"	B + 3 3/8"	3 1/8"	C2 + 2 3/8"
B + 11/16"	B + 4 1/8"	4"	C2 + 2 3/4"
B + 13/16"	B + 4 7/8"	4 3/4"	C2 + 3 1/2"
B + 1 1/8"	B + 6 3/4"	6"	C2 + 4 1/4"

1) Depending on the type of connection and associated end plate use, the thickness may need to be modified to comply with accepted local design codes.

- Use Lindapter's Bolt Length Calculator on page 10 to calculate the correct bolt length for your application.
- If drilling through the flange of the supported steel please contact Lindapter to ensure suitability.

Type A

Lindapter's standard clamp is used to resist moderate tensile loading. Can also be used with Type B in a Girder Clamp configuration.



Recess (Grd. 5 bolt sizes 1/2", 5/8" or 3/4" only)

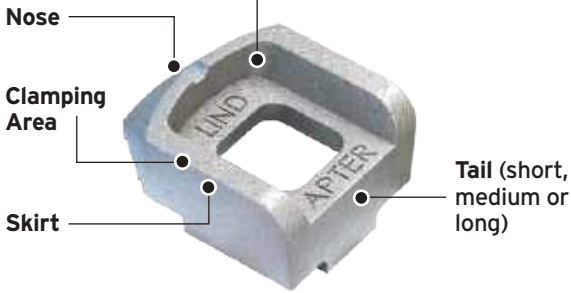

- Recessed top holds the bolt captive while the nut is tightened (Grd. 5 bolt sizes 1/2", 5/8" or 3/4" only).
- Supports up to 17,720lbs tensile load in a four-bolt configuration.
- Independently evaluated for fatigue resistance per EN 1993-1-9.
- For products suitable for tapered beams over 4°, see **page 11**.
- For higher loads the Type AF should be used, see **pages 18-19**.



For Safe Working Loads or LRFD / ASD data turn to [page 29](#)



If you are using A325 bolts, the Type B should be used. See [page 31](#)



Watch the Type A installation video at www.Lindapter.com

Can we help? Try Lindapter's free connection detailing. Turn to page 6 for more details

Step 1 - Email your requirement to support@Lindapter.com

Step 2 - Our experienced Engineers will design your custom solution

Step 3 - An Engineer will send a detailed connection drawing



LRFD / ASD Loads and Safe Working Loads for Type A

Material: Malleable iron, zinc plated or hot dip galvanized.

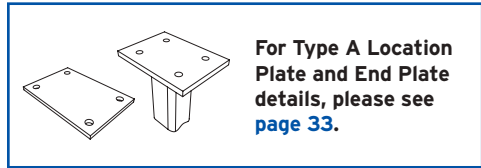
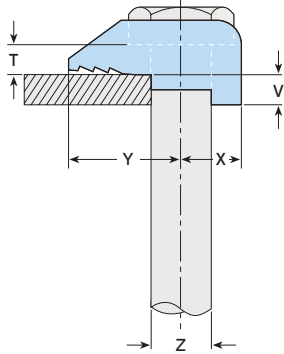

LRFD / ASD STATIC LOAD DATA															
Product Code	Bolt Grd. 5 Z	Static Loads				Minimum Plate Thickness (see page 33)		Tightening Torque* ft lb	Y	X	Dimensions			T	Width
		LRFD Design Strength		ASD Allowable Strength		Location Plate	End Plate				Tail Length V				
		Tension 1/bolt lbs	Slip 2/bolts lbs	Tension 1/bolt lbs	Slip 2/bolts lbs						short	medium	long		
LA037 ¹⁾	3/8"	1251	-	782	-	5/16"	1/2"	15	13/16"	7/16"	5/32"	3/16"	9/32"	3/16"	1"
LA050	1/2"	2919	434	1824	271	3/8"	1/2"	50	1"	1/2"	3/16"	1/4"	3/8"	1/4"	1 1/8"
LA062	5/8"	3625	644	2265	403	3/8"	5/8"	108	13/16"	5/8"	1/4"	5/16"	7/16"	5/16"	13/8"
LA075	3/4"	7159	1669	4475	1043	1/2"	7/8"	210	17/16"	3/4"	5/16"	3/8"	1/2"	3/8"	1 13/16"
LA100 ¹⁾	1"	9764	1965	6103	1228	5/8"	1"	362	17/8"	1 1/8"	3/8"	1/2"	5/8"	1/2"	2 1/8"

SAFE WORKING LOAD DATA														
Product Code	Bolt Grd. 5 Z	Safe Working Loads (Factor of Safety 5:1)		Minimum Plate Thickness (see page 33)		Tightening Torque* ft lb	Y	X	Dimensions			T	Width	
		Tensile Resistance / 1 Bolt	Slip Resistance / 2 Bolts	Location Plate	End Plate				Tail Length V					
		lbs	lbs						short	medium	long			
LA037 ¹⁾	3/8"	337	-	5/16"	1/2"	15	13/16"	7/16"	5/32"	3/16"	9/32"	3/16"	1"	
LA050	1/2"	1304	202	3/8"	1/2"	50	1"	1/2"	3/16"	1/4"	3/8"	1/4"	1 1/8"	
LA062	5/8"	1911	382	3/8"	5/8"	108	13/16"	5/8"	1/4"	5/16"	7/16"	5/16"	13/8"	
LA075	3/4"	3305	674	1/2"	7/8"	210	17/16"	3/4"	5/16"	3/8"	1/2"	3/8"	1 13/16"	
LA100 ¹⁾	1"	4430	1012	5/8"	1"	362	17/8"	1 1/8"	3/8"	1/2"	5/8"	1/2"	2 1/8"	

¹⁾ Requires Type W washer (product code LW037), see page 32.
 * Torque figures based on fasteners in an unlubricated condition. For further information see page 78.

➔ If you are using A325 bolts, the Type B should be used (see page 31).

Type B

The flat-top version of Lindapter's standard clamp, for moderate tensile loading. Can also be used with Type A in a Girder Clamp configuration.

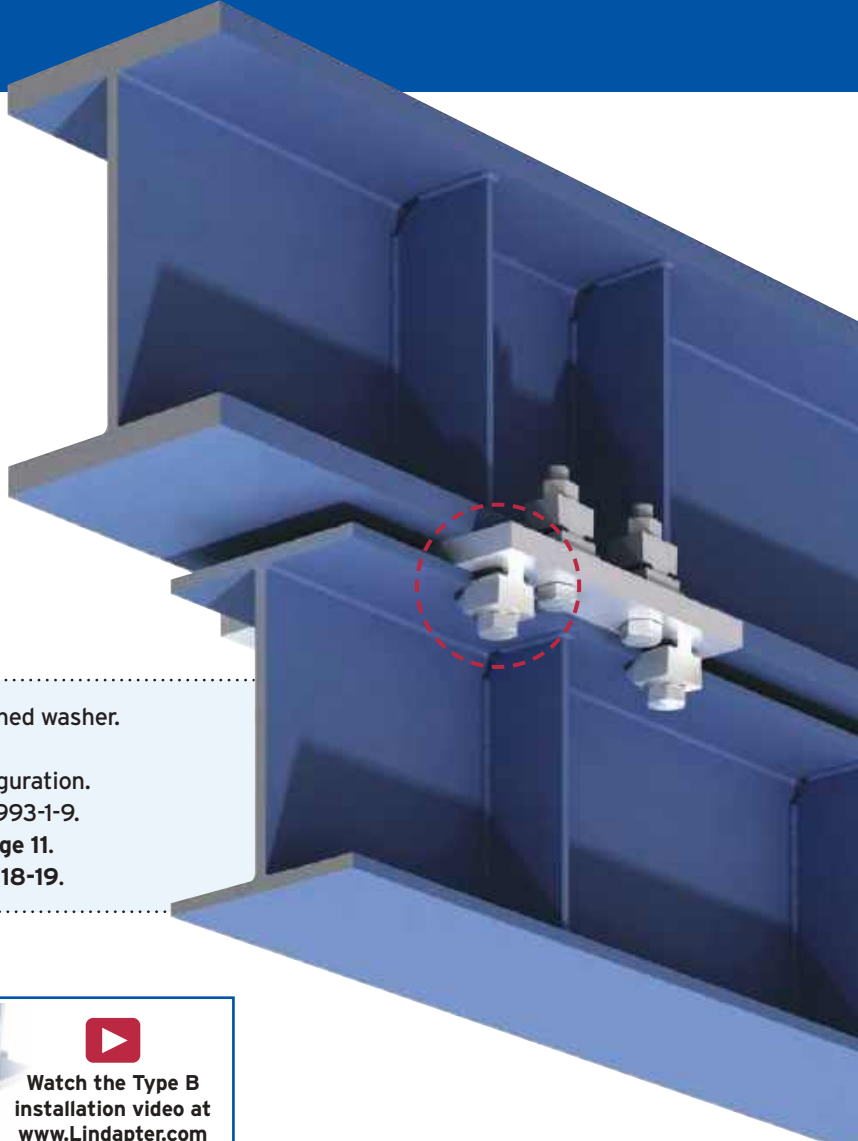
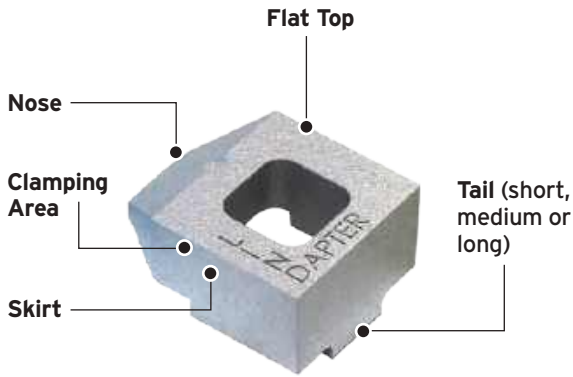

- Flat top allows the bolt head or nut to rotate on a hardened washer.
- Suitable for use with bolts, studs, tie rods and J-bolts.
- Supports up to 17,720lbs tensile load in a four-bolt configuration.
- Independently evaluated for fatigue resistance per EN 1993-1-9.
- For products suitable for tapered beams over 4°, see **page 11**.
- For higher loads the Type AF should be used, see **pages 18-19**.

For Safe Working Loads or LRFD / ASD data turn to [page 31](#)

Watch the Type B installation video at www.Lindapter.com

Can we help? Try Lindapter's online Girder Clamp Configurator at www.Lindapter.com

Step 1 - Select your connection requirement (Beam-to-Beam or End Plate)

Step 2 - Input your connection details

Step 3 - Choose your solution

GIRDER CLAMPS
LIFTING POINTS
HOLLOW-BOLT
FLOOR CONNECTIONS
PIPE SUPPORTS
FAQS & CASE STUDIES

LRFD / ASD Loads and Safe Working Loads for Type B

Material: Malleable iron, zinc plated or hot dip galvanized.

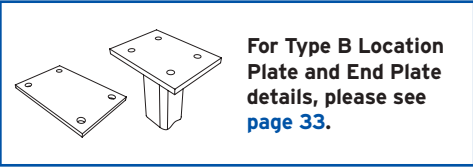
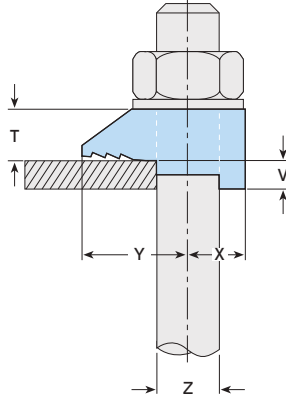

LRFD / ASD STATIC LOAD DATA															
Product Code	Bolt Grd. 5 Z	Static Loads				Minimum Plate Thickness (see page 33)		Tightening Torque* ft lb	Y	X	Dimensions			T	Width
		Tension 1/bolt lbs	Slip 2/bolts lbs	Tension 1/bolt lbs	Slip 2/bolts lbs	Location Plate	End Plate				Tail Length V				
											short	medium	long		
LA037 ¹⁾	3/8"	1251	-	782	-	5/16"	1/2"	15	13/16"	7/16"	5/32"	3/16"	9/32"	3/8"	1"
LA050	1/2"	2919	434	1824	271	3/8"	1/2"	50	1"	1/2"	3/16"	1/4"	3/8"	1/2"	1 1/8"
LA062	5/8"	3625	644	2265	403	3/8"	5/8"	108	1 3/16"	5/8"	1/4"	5/16"	7/16"	5/8"	1 3/8"
LA075	3/4"	7159	1669	4475	1043	1/2"	7/8"	210	1 7/16"	3/4"	5/16"	3/8"	1/2"	3/4"	1 13/16"
LA100	1"	9764	1965	6103	1228	5/8"	1"	362	1 7/8"	1"	3/8"	1/2"	5/8"	1"	2 1/8"

SAFE WORKING LOAD DATA															
Product Code	Bolt Grd. 5 Z	Safe Working Loads (Factor of Safety 5:1)		Minimum Plate Thickness (see page 33)		Tightening Torque* ft lb	Y	X	Dimensions			T	Width		
		Tensile Resistance / 1 Bolt lbs	Slip Resistance / 2 Bolts lbs	Location Plate	End Plate				Tail Length V						
											short	medium	long		
LB037 ¹⁾	3/8"	337	-	5/16"	1/2"	15	13/16"	7/16"	5/32"	3/16"	9/32"	3/8"	1"		
LB050	1/2"	1304	202	3/8"	1/2"	50	1"	1/2"	3/16"	1/4"	3/8"	1/2"	1 1/8"		
LB062	5/8"	1911	382	3/8"	5/8"	108	1 3/16"	5/8"	1/4"	5/16"	7/16"	5/8"	1 3/8"		
LB075	3/4"	3305	674	1/2"	7/8"	210	1 7/16"	3/4"	5/16"	3/8"	1/2"	3/4"	1 13/16"		
LB100	1"	4430	1012	5/8"	1"	362	1 7/8"	1"	3/8"	1/2"	5/8"	1"	2 1/8"		

1) Requires a hardened washer under the bolt head.
* Torque figures based on fasteners in an unlubricated condition. For further information see page 78.

Packing Pieces for Types A and B

These packing pieces are compatible with the Type A and Type B clamps and are used to increase the clamping range to suit flange thicknesses. Types A and B are available with three different tail lengths (short, medium or long) and the correct combination of packing pieces should be used.

Packing Pieces

Type CW

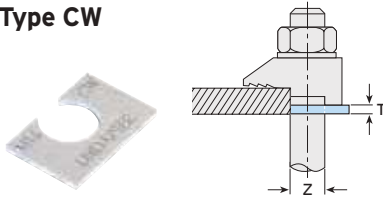

Mild steel, zinc plated or hot dip galvanized.

Product Code	Bolt Size Z	Dimension T
LCW037	3/8"	1/16"
LCW050	1/2"	1/8"
LCW062	5/8"	1/8"
LCW075	3/4"	3/16"
LCW100	1"	3/16"

Type P1 short / Type P2 short

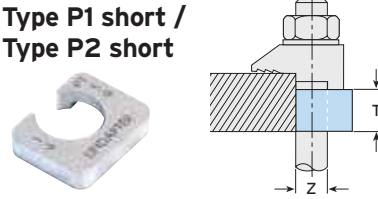

Mild steel, malleable iron, zinc plated or hot dip galv.

Product Code	Bolt Size Z	Dimension T
LP1037S	3/8"	3/16"
LP1050S	1/2"	1/4"
LP1062S	5/8"	5/16"
LP1075S	3/4"	3/8"
LP1100S	1"	1/2"

LP2037S	3/8"	3/8"
LP2050S	1/2"	1/2"
LP2062S	5/8"	5/8"
LP2075S	3/4"	3/4"
LP2100S	1"	1"

Also Available

Type W

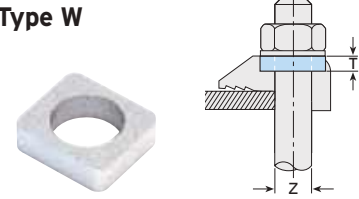

Mild steel, malleable iron, zinc plated or hot dip galv.

Product Code	Bolt Size Z	Dimension T
LW037	3/8"	3/16"
LW050	1/2"	1/4"
LW062	5/8"	5/16"
LW075	3/4"	3/8"

Note: Type W is used to fill the recess in the Type A to convert it into a flat top clamp which enables an A325 structural bolt head or nut to be rotated on a hardened washer.

Tail Length / Packing Piece Combinations for Types A and B

Choose the correct combination for your Type A/B configuration using the table below. For example, a 5/8" Type A/B on a 1 1/8" flange requires 1 x Type A/B short tail (S), 2 x Type CW and 1 x Type P2S.

- For thicker flanges contact Lindapter.
- Other combinations than what is shown here may be possible. Contact our Technical Support team to discuss your requirements.
- If your flange thickness exceeds the flange thickness listed in the table, use the packing piece combination from the next largest flange thickness. Interpolation of table values is not permitted.

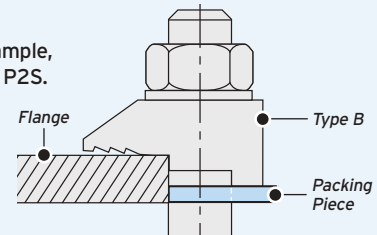

Flange Thickness	3/8"				1/2"				5/8"				3/4"				1"			
	A/B	CW	P1S	P2S	A/B	CW	P1S	P2S	A/B	CW	P1S	P2S	A/B	CW	P1S	P2S	A/B	CW	P1S	P2S
3/16"	M	-	-	-	S	-	-	-	X	-	-	-	X	-	-	-	X	-	-	-
1/4"	S	1	-	-	M	-	-	-	S	-	-	-	S	-	-	-	X	-	-	-
5/16"	L	-	-	-	M	1	-	-	M	-	-	-	S	-	-	-	S	-	-	-
3/8"	S	-	1	-	L	-	-	-	S	1	-	-	M	-	-	-	S	-	-	-
7/16"	L	2	-	-	M	2	-	-	L	-	-	-	S	1	-	-	M	-	-	-
1/2"	L	3	-	-	S	1	1	-	S	2	-	-	L	-	-	-	M	-	-	-
9/16"	S	-	-	1	L	2	-	-	L	1	-	-	M	1	-	-	S	1	-	-
5/8"	S	1	-	1	L	-	1	-	M	-	1	-	L	1	-	-	L	-	-	-
11/16"	L	-	-	1	M	2	1	-	L	2	-	-	S	-	1	-	S	2	-	-
3/4"	S	-	1	1	S	1	-	1	L	-	1	-	S	3	-	-	L	1	-	-
13/16"	M	-	1	1	M	1	-	1	L	3	-	-	M	-	1	-	L	1	-	-
7/8"	L	-	1	1	S	-	1	1	M	2	1	-	M	3	-	-	S	-	1	-
15/16"	S	-	-	2	M	-	1	1	M	-	-	1	M	1	1	-	M	-	1	-
1"	M	-	-	2	S	1	1	1	L	2	1	-	S	2	1	-	S	1	1	-
1 1/16"	L	-	-	2	M	1	1	1	L	-	-	1	S	-	-	1	L	-	1	-
1 1/8"	L	1	-	2	S	-	-	2	S	2	-	1	M	2	1	-	L	-	1	-
1 3/16"	-	-	-	-	M	-	-	2	L	1	-	1	M	-	-	1	S	2	1	-
1 1/4"	-	-	-	-	S	1	-	2	M	-	1	1	S	1	-	1	L	1	1	-

A/B = Type A/B | S = Type A/B short | M = Type A/B medium | L = Type A/B long | CW = Type CW | P1S/P2S = Type P1/P2 short | X = Not possible

Location and End Plates for Types A, B and BR

These plates ensure the clamps and bolts are located in the correct position relative to the supporting steel. If you would like help choosing a suitable plate, please contact Lindapter.

Location Plate

Location plates are required when securing two sections together with clamps attached to the upper and lower sections with both clamps directly opposing each other.

The plate is positioned between the two sections to hold the bolts at the correct centers and should be fabricated to the dimensions shown in the table below.

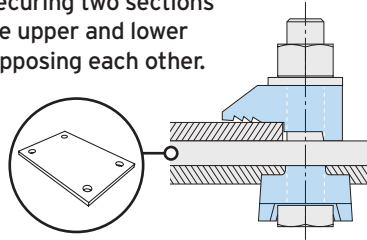

Material: Structural steel grade A36. For other grades contact Lindapter.

Bolt Size	Hole \emptyset d	Plate Thickness	Hole Centers C1	Length min L1	Hole Centers C2	Width min L2
3/8"	7/16"	5/16"	$B_1 + 7/16"$	$B_1 + 1 3/4"$	$B_2 + 7/16"$	$B_2 + 1 3/4"$
1/2"	9/16"	3/8"	$B_1 + 9/16"$	$B_1 + 2 1/4"$	$B_2 + 9/16"$	$B_2 + 2 1/4"$
5/8"	11/16"	3/8"	$B_1 + 11/16"$	$B_1 + 2 3/4"$	$B_2 + 11/16"$	$B_2 + 2 3/4"$
3/4"	13/16"	1/2"	$B_1 + 13/16"$	$B_1 + 3 1/2"$	$B_2 + 13/16"$	$B_2 + 3 1/2"$
1"	1 1/16"	5/8"	$B_1 + 1 1/8"$	$B_1 + 4 1/4"$	$B_2 + 1 1/8"$	$B_2 + 4 1/4"$

LOCATION PLATE DIMENSIONS

L1 = Location Plate Length, L2 = Location Plate Width, B1, B2 = Flange Width, C1, C2 = Hole Centers, d = Hole \emptyset

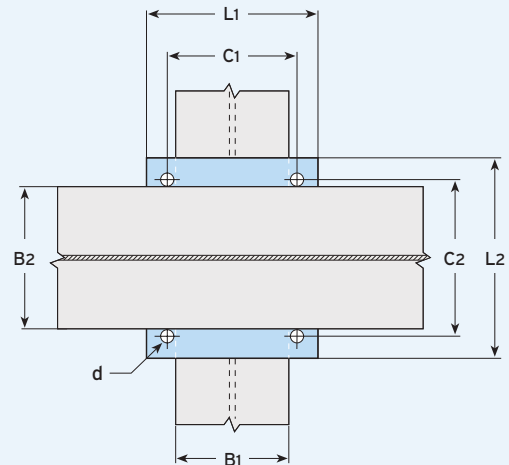

End Plate

End Plates should be used when clamps are attached to the supporting section only.

The End Plate holds the bolts at the correct centers and should be fabricated to the dimensions shown in the table below.

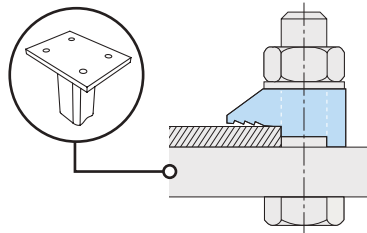

Material: Structural steel grade A36. For other grades contact Lindapter.

Bolt Size	Hole \emptyset d	Plate Thickness ¹⁾	Hole Centers C1	Length min L1	Hole Centers min C2	Width min L2
3/8"	7/16"	1/2"	$B + 7/16"$	$B + 1 3/4"$	2"	$C_2 + 1 5/8"$
1/2"	9/16"	1/2"	$B + 9/16"$	$B + 2 1/4"$	$2 3/8"$	$C_2 + 2"$
5/8"	11/16"	5/8"	$B + 11/16"$	$B + 2 3/4"$	$2 7/8"$	$C_2 + 2 3/8"$
3/4"	13/16"	7/8"	$B + 13/16"$	$B + 3 1/2"$	$3 5/8"$	$C_2 + 2 3/4"$
1"	1 1/16"	1"	$B + 1 1/8"$	$B + 4 1/4"$	$4 3/8"$	$C_2 + 3 5/8"$

1) Depending on the type of connection and associated end plate use, the thickness may need to be modified to comply with accepted local design codes.

END PLATE DIMENSIONS

L1 = End Plate Length, L2 = End Plate Width, B = Flange Width, C1, C2 = Hole Centers, d = Hole \emptyset

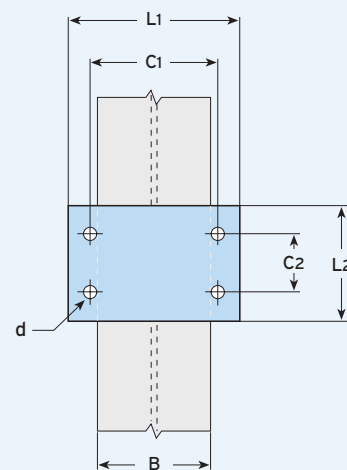

- Use Lindapter's Bolt Length Calculator on page 10 to calculate the correct bolt length for your application.
- If drilling through the flange of the supported steel please contact Lindapter to ensure suitability.

Type LS

Providing excellent corrosion resistance, Lindapter's stainless steel clamp self-adjusts to suit a range of flange thicknesses.

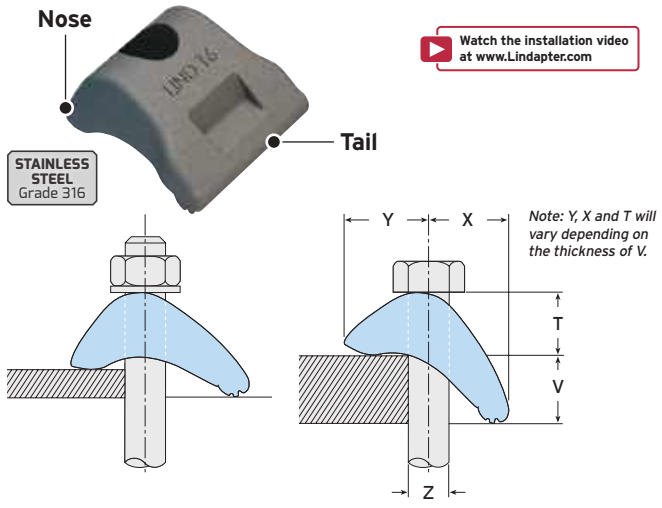

- Made from high strength stainless steel grade 316.
- Self-adjusts to suit a range of flange thicknesses.
- For parallel and tapered flanges up to and including 10°.
- The tail spans slotted clearance holes.

Material: Cast stainless steel grade 316.

LRFD / ASD STATIC LOAD DATA													
Product Code	Bolt ¹⁾ Z	Static Loads				Minimum Plate Thickness (see page 35)		Tight. Torque* ft lb	Clamping Range V	Dimensions			
		LRFD Design Strength		ASD Allowable Strength		Location Plate	End Plate			Y	X	T	Width
		Tension / 1 Bolt lbs	Slip / 2 Bolts lbs	Tension / 1 Bolt lbs	Slip / 2 Bolts lbs								
LLS037	3/8"	2629	738	1643	461	3/8"	3/8"	30	1/8" - 9/16"	5/8" - 3/4"	11/16" - 15/16"	5/8" - 13/16"	1 1/2"
LLS050	1/2"	3794	1021	2383	638	1/2"	5/8"	60	1/8" - 13/16"	5/8" - 7/8"	11/16" - 1 1/8"	5/8" - 7/8"	1 9/16"
LLS062	5/8"	6744	1982	3822	1239	5/8"	3/4"	148	1/8" - 1"	7/8" - 1"	1 1/16" - 1 7/16"	3/4" - 1 1/8"	2 3/16"
LLS075	3/4"	8167	3296	5104	2060	3/4"	1"	295	1/8" - 13/16"	15/16" - 1 1/4"	1" - 1 5/8"	7/8" - 1 1/4"	2 3/8"

SAFE WORKING LOAD DATA													
Product Code	Bolt ¹⁾ Z	Safe Working Loads				Minimum Plate Thickness (see page 35)		Tightening Torque* ft lb	Clamping Range V	Dimensions			
		Tensile Resistance / 1 Bolt (FOS 5:1)		Slip Resistance ²⁾ / 2 Bolts (FOS 2:1)		Location Plate	End Plate			Y	X	T	Width
		lbs	lbs	lbs	lbs								
LLS037	3/8"	675	337	3/8"	3/8"	30	1/8" - 9/16"	5/8" - 3/4"	11/16" - 15/16"	5/8" - 13/16"	1 1/2"		
LLS050	1/2"	1574	450	1/2"	5/8"	60	1/8" - 13/16"	5/8" - 7/8"	11/16" - 1 1/8"	5/8" - 7/8"	1 9/16"		
LLS062	5/8"	2248	675	5/8"	3/4"	148	1/8" - 1"	7/8" - 1"	1 1/16" - 1 7/16"	3/4" - 1 1/8"	2 3/16"		
LLS075	3/4"	4047	1124	3/4"	1"	295	1/8" - 13/16"	15/16" - 1 1/4"	1" - 1 5/8"	7/8" - 1 1/4"	2 3/8"		

1) LLS037: ASTM F593G (316) Stainless Steel / ASTM A320 B8M CL2 (316) Stainless Steel
 LLS050, LLS062 & LLS075: ASTM A320 B8M CL2 (316) Stainless Steel / ASTM A193 B8M CL2 (316) Stainless Steel
 2) Slip resistant values calculated against movement exceeding 0.004" / 0.1mm.
 * Torque figures based on fasteners in an unlubricated condition. For further information see page 78.

Packing pieces are available to increase the clamping range, please see [page 35](#).

For Type LS Location Plate and End Plate details, please see [page 35](#).

GIRDER CLAMPS

LIFTING POINTS

HOLLO-BOLT

FLOOR CONNECTIONS

PIPE SUPPORTS

FAQS & CASE STUDIES

Packing Pieces and Plate Details for Type LS

Stainless steel packing pieces are available to increase the clamping range of the Type LS, please select the correct packing combination from the table below. This page also contains information for designing location / end plates.

Packing Pieces

Type LSP2

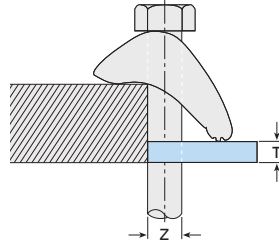

Material: Stainless steel grade 316.

Product Code	Bolt Size Z	Dimension T
LLS037P2	3/8"	3/8"
LLS050P2	1/2"	3/8"
LLS062P2	5/8"	3/8"
LLS075P2	3/4"	3/8"

Location Plate

Location Plates are required when securing two sections together with clamps attached to the upper and lower sections with both clamps directly opposing each other. The plate is positioned between the two sections to hold the bolts at the correct centers and should be fabricated to the dimensions shown in the table below.

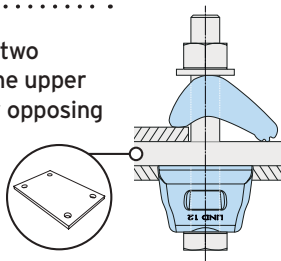

Material: Stainless steel grade 316.

Bolt Size	Hole \emptyset d	Plate Thickness	Hole Centers C1	Length min L1	Hole Centers C2	Width min L2
3/8"	7/16"	3/8"	$B1 + 7/16"$	$B1 + 2 3/4"$	$B2 + 7/16"$	$B2 + 2 3/4"$
1/2"	9/16"	1/2"	$B1 + 9/16"$	$B1 + 3 1/8"$	$B2 + 9/16"$	$B2 + 3 1/8"$
5/8"	11/16"	5/8"	$B1 + 11/16"$	$B1 + 4"$	$B2 + 11/16"$	$B2 + 4"$
3/4"	13/16"	3/4"	$B1 + 13/16"$	$B1 + 5 1/8"$	$B2 + 13/16"$	$B2 + 5 1/8"$

LOCATION PLATE DIMENSIONS

L1 = Location Plate Length, L2 = Location Plate Width, B1, B2 = Flange Width, C1, C2 = Hole Centers, d = Hole \emptyset

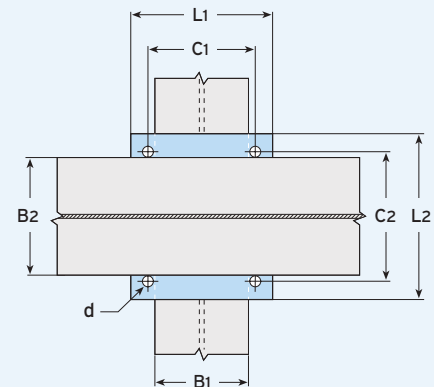

End Plate

End Plates should be used when clamps are attached to the supporting section only. The End Plate holds the bolts at the correct centers and should be fabricated to the dimensions shown in the table below.

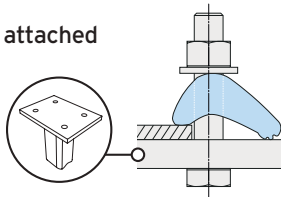

Material: Stainless steel grade 316.

Bolt Size	Hole \emptyset d	Plate Thickness ¹⁾	Hole Centers C1	Length min L1	Hole Centers min C2	Width min L2
3/8"	7/16"	3/8"	$B + 7/16"$	$B + 2 3/4"$	3 1/8"	$C2 + 2 3/8"$
1/2"	9/16"	5/8"	$B + 9/16"$	$B + 3 1/8"$	3 1/8"	$C2 + 2 3/8"$
5/8"	11/16"	3/4"	$B + 11/16"$	$B + 4"$	4 3/8"	$C2 + 3 1/8"$
3/4"	13/16"	1"	$B + 13/16"$	$B + 5 1/8"$	4 3/4"	$C2 + 3 9/16"$

¹⁾ Depending on the type of connection and associated end plate use, the thickness may need to be modified to comply with accepted local design codes.

END PLATE DIMENSIONS

L1 = End Plate Length, L2 = End Plate Width, B = Flange Width, C1, C2 = Hole Centers, d = Hole \emptyset

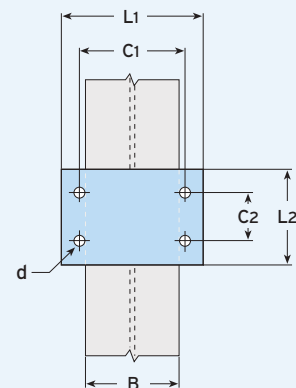

- Use Lindapter's Bolt Length Calculator on page 10 to calculate the correct bolt length for your application.
- If drilling through the flange of the supported steel please contact Lindapter to ensure suitability.

Type BR

Primarily a steel connection for use with either parallel or tapered flanges up to and including 8°. The tail is available in two lengths and spans slotted clearance holes.

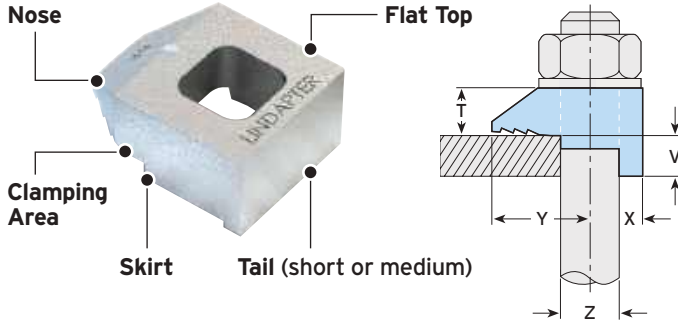
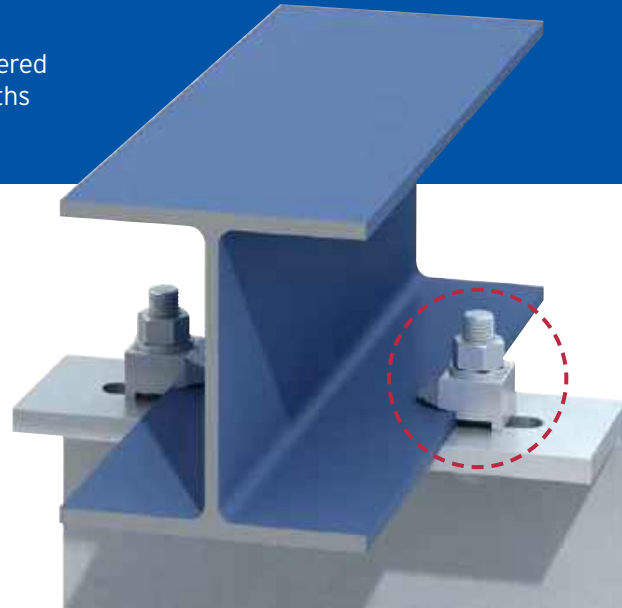

Material: Malleable iron, zinc plated or hot dip galvanized.

Product Code	Bolt Grd. 5 / A325 Z	Safe Working Loads (FOS 5:1)			Reduced Torque / Loads (not suitable for slip conditions)		Dimensions					
		Tensile Resistance / 1 Bolt lbs	Slip Resistance / 2 Bolts lbs	Tightening Torque* ft lb	Tensile Resistance / 1 Bolt lbs	Tightening Torque* ft lb	Y	X	Tail Length V		Width	
LBR050	1/2"	1304	202	50	832	29	1"	1/2"	5/32"	1/4"	1/2"	1 1/8"
LBR062	5/8"	1911	382	108	1169	69	1 3/16"	5/8"	1/4"	5/16"	5/8"	1 3/8"
LBR075	3/4"	3305	674	210	1933	131	1 3/8"	7/8"	9/32"	3/8"	3/4"	1 5/8"

* Torque figures based on fasteners in an unlubricated condition. For further information see page 78.

- ▶ Please ensure the anchor device is suitable for the torque value shown above.
- ▶ Contact Lindapter to ensure suitability of the component for application.

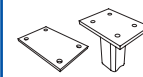

For Type BR Location Plate and End Plate details, please see [page 33](#).

Packing Pieces

Type CW

Mild steel, zinc plated or hot dip galvanized.

Product Code	Bolt Size Z	Dimension T
LCW050	1/2"	1/8"
LCW062	5/8"	1/8"
LCW075	3/4"	3/16"

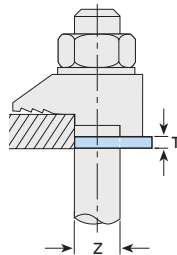

Type P1 / P2 short

Mild steel, malleable iron, zinc plated or hot dip galvanized.

Product Code	Bolt Size Z	Dimension T
LP1050S	1/2"	1/4"
LP1062S	5/8"	5/16"
LP1075S	3/4"	3/8"
LP2050S	1/2"	1/2"
LP2062S	5/8"	5/8"
LP2075S	3/4"	3/4"

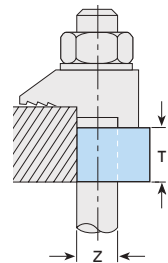

Packing Piece Combinations for Type BR

- ▶ If your flange thickness exceeds the flange thickness listed in the table, use the packing piece combination from the next largest flange thickness. Interpolation of table values is not permitted.
- ▶ For thicker flanges contact Lindapter.
- ▶ Other combinations than what is shown here may be possible. Please contact our Technical Support team to discuss your requirements.

Flange Thickness	1/2"				5/8"				3/4"			
	BR	CW	P1S	P2S	BR	CW	P1S	P2S	BR	CW	P1S	P2S
3/16"	S	-	-	-	X	-	-	-	X	-	-	-
1/4"	M	-	-	-	S	-	-	-	S	-	-	-
5/16"	M	1	-	-	M	-	-	-	S	-	-	-
3/8"	S	2	-	-	S	1	-	-	M	-	-	-
7/16"	M	2	-	-	M	1	-	-	S	1	-	-
1/2"	S	1	1	-	S	2	-	-	S	1	-	-
9/16"	M	1	1	-	S	-	1	-	M	1	-	-
5/8"	S	2	1	-	M	-	1	-	S	2	-	-
11/16"	M	2	1	-	S	1	1	-	S	-	1	-
3/4"	S	1	-	1	M	1	1	-	S	3	-	-
13/16"	M	1	-	1	S	2	1	-	M	-	1	-
7/8"	S	-	1	1	M	2	1	-	M	3	-	-
15/16"	M	-	1	1	M	-	-	1	M	1	1	-
1"	S	1	1	1	S	1	-	1	S	2	1	-
1 1/16"	M	1	1	1	M	1	-	1	S	-	-	1
1 1/8"	S	-	-	2	S	2	-	1	M	2	1	-
1 3/16"	M	-	-	2	M	2	-	1	M	-	-	1
1 1/4"	S	1	-	2	M	-	1	1	S	1	-	1

S = Type BR short | M = Type BR medium | CW = Type CW | P1S = P1 short | P2S = P2 short | X = Not possible

Type FC - Flush Clamp

A full connection system that adjusts to fit a variety of beam types. This pre-configured assembly does not require a location plate and is ready for assembly 'out of the box'.

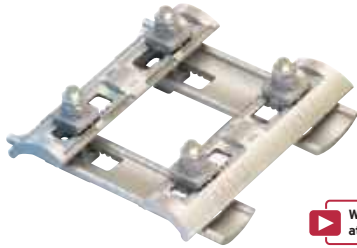

Watch the installation video at www.Lindapter.com

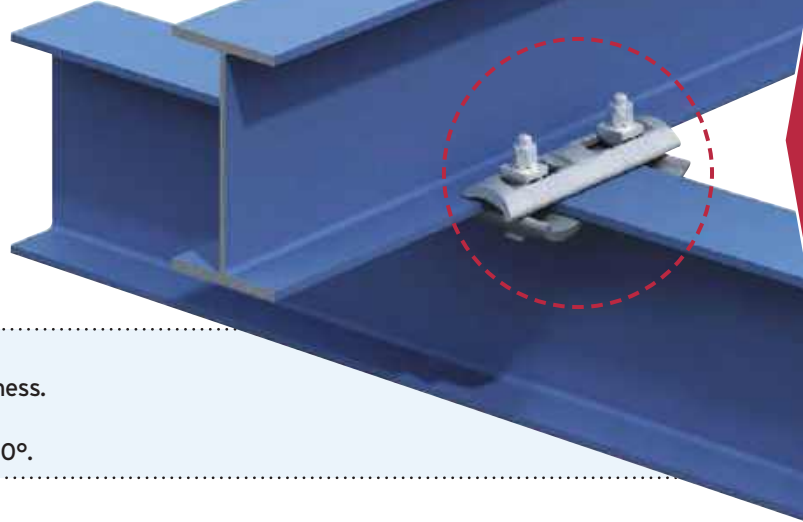

- 'All-in-one' device for connecting steel sections.
- Adjustable to suit both beam width and flange thickness.
- Quick and easy to install.
- For parallel and tapered flanges up to and including 10°.

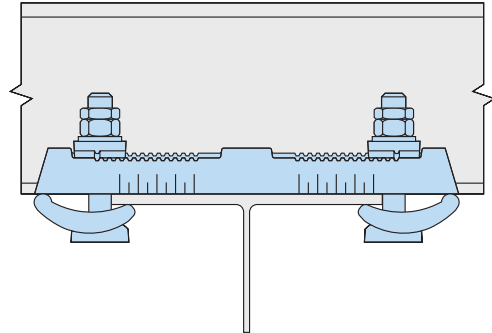
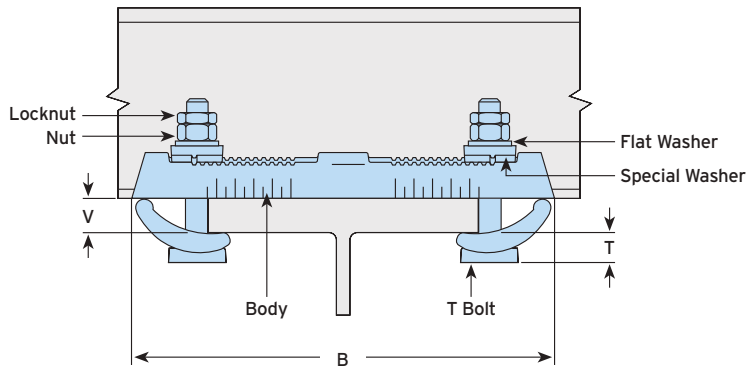

Material: Forged steel, zinc plated plus JS500.

Product Code	Special Bolt Size Z	Safe Working Loads (FOS 5:1)		Tightening Torque*	Clamping Range		Dimensions	
		Tensile Resistance / 4 Bolts lbs	Slip Resistance / 4 Bolts lbs		Flange Thickness V	Flange Width ¹⁾	T	B
LFCM16	M16 (5/8")	6744	1686	108	3/16" - 3/4"	3" - 7"	7/8" - 1 1/16"	12"

1) Depending on beam connection angles (see table below).

* Torque figures based on fasteners in an unlubricated condition. For further information see page 78.

Minimum Possible Beam Connection Angles

		Top Beam					
Bottom Beam		Flange Width	3"	4"	5"	6"	7"
	3"		45°	50°	55°	65°	75°
	4"		50°	50°	55°	65°	75°
	5"		55°	55°	55°	65°	75°
	6"		65°	65°	65°	65°	75°
	7"		75°	75°	75°	75°	80°

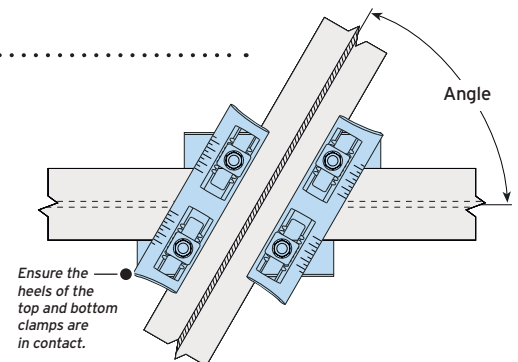

Type F9

A flange clamp for connecting parallel running steel sections with flanges of the same width. Can be used with bolts or threaded rod.

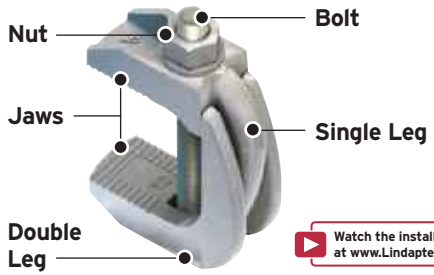

▶ Watch the installation video at www.Lindapter.com

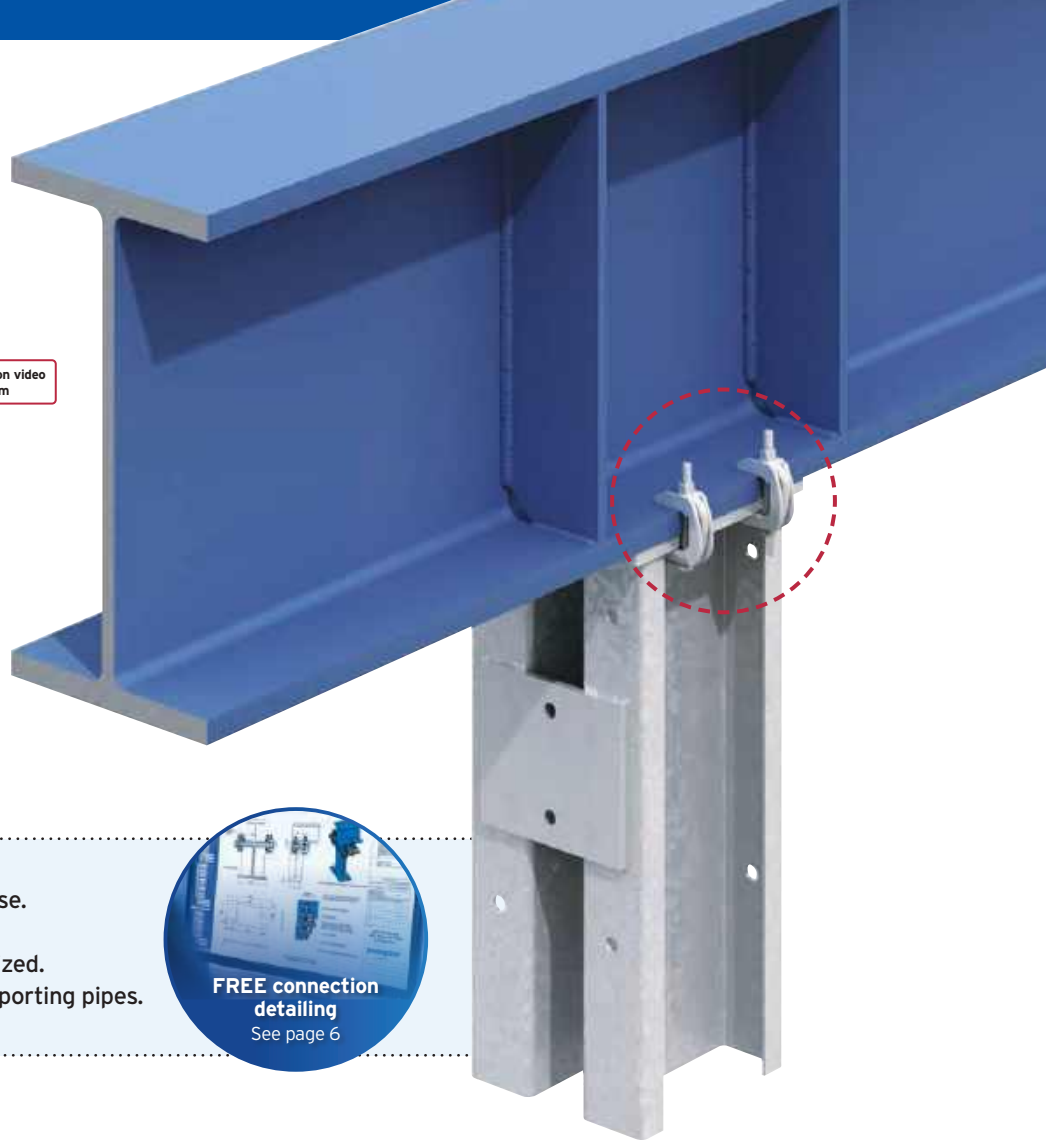
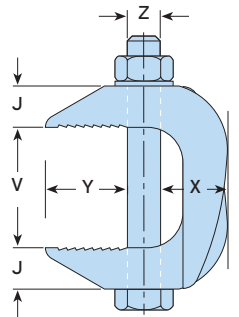

- Fast, cost effective installation.
- Perfect for temporary or permanent use.
- Large clamping range.
- Available zinc plated or hot dip galvanized.
- Can be used with threaded rod for supporting pipes.
- Supplied with or without a metric bolt.



Material: Malleable iron, zinc plated or hot dip galvanized.

Without Bolt		With Bolt		Safe Working Loads (FOS 5:1)	Tightening Torque*	Clamping Range V	Dimensions			
Product Code	Bolt / Rod Z	Product Code	Bolt Z				Tensile Resistance / 1 Bolt lbs	ft lb	Y	J
LF9037NB	3/8"	LF9037WB	M10 (3/8")	440	15	3/4" - 1 11/16"	1"	1/2"	3/4"	15/16"
LF9050NB	1/2"	LF9050WB	M12 (1/2")	630	29	1" - 2 3/8"	1 3/8"	1 1/16"	1 5/16"	1 3/16"
LF9062NB	5/8"	LF9062WB	M16 (5/8")	1260	69	1 1/8" - 2 3/4"	1 11/16"	1 3/16"	1 1/8"	1 3/8"
LF9075NB	3/4"	LF9075WB	M20 (3/4")	1880	131	1 1/4" - 3 1/4"	2"	1"	1 7/8"	1 3/4"
LF9100NBHGD ¹⁾	1"	LF9100WBHGD ¹⁾	M24 (1")	3147	173	1 3/4" - 3 3/4"	3"	1 1/2"	2 3/16"	2 1/2"

1) Available in Hot Dip Galvanized only.
* Torque figures based on fasteners in an unlubricated condition. For further information see page 78.

- ▶ Not suitable for tapered flanges.
- ▶ Supplied without bolt or with bolt (contact your local distributor for details / options).

GIRDER CLAMPS

LIFTING POINTS

HOLLO-BOLT

FLOOR CONNECTIONS

PIPE SUPPORTS

FAQS & CASE STUDIES

Typical Applications for Girder Clamps

Popular connection assemblies are shown below. They represent a fraction of the possibilities as Lindapter's clamps are used all over the world to connect almost every type of steel section. Please contact Lindapter to discuss your connection requirement.

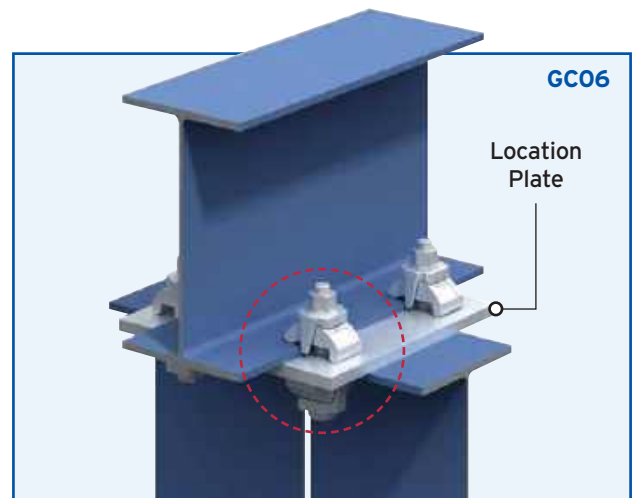
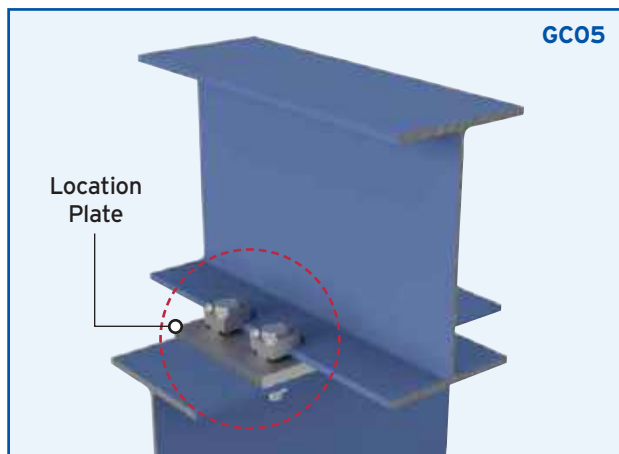
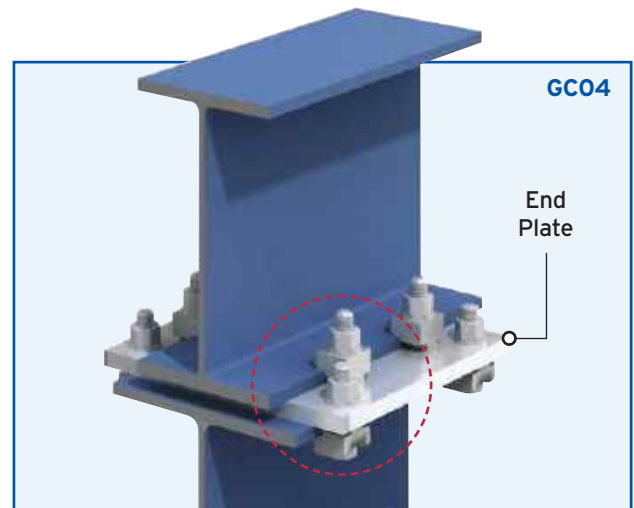
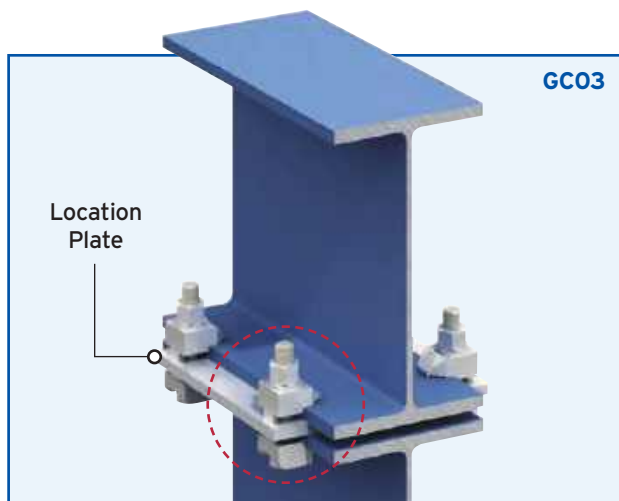
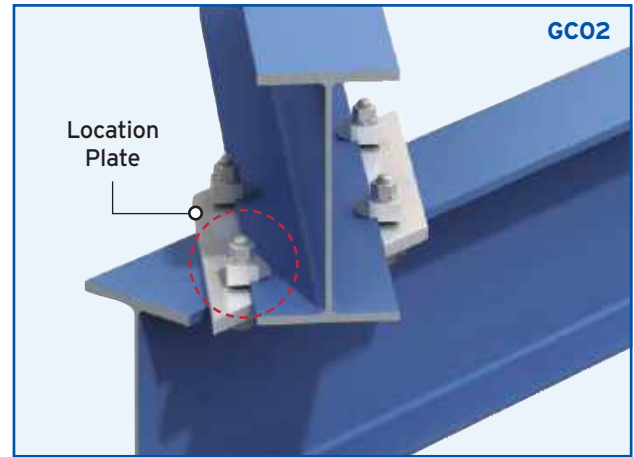
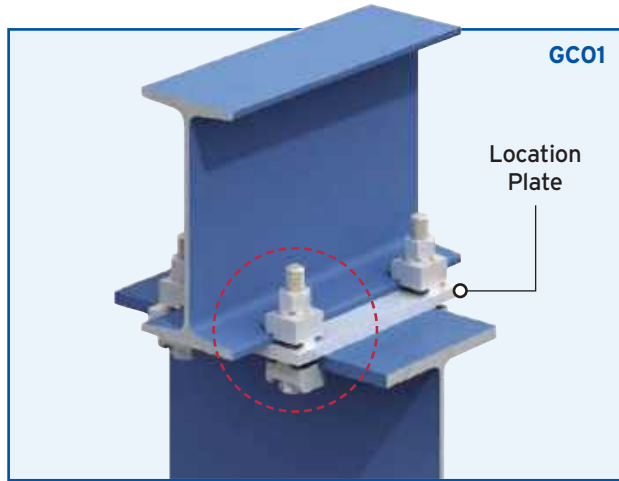

Typical Applications for Girder Clamps

Examples of popular connection arrangements are continued below:

GIRDER CLAMPS

LIFTING POINTS

HOLLO-BOLT

FLOOR CONNECTIONS

PIPE SUPPORTS

FAQS & CASE STUDIES

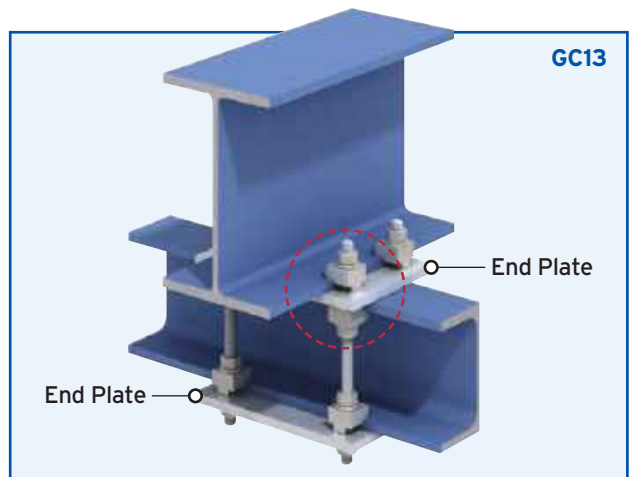
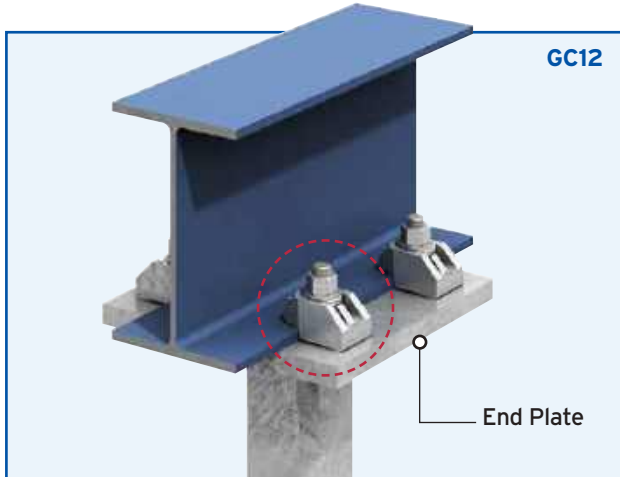
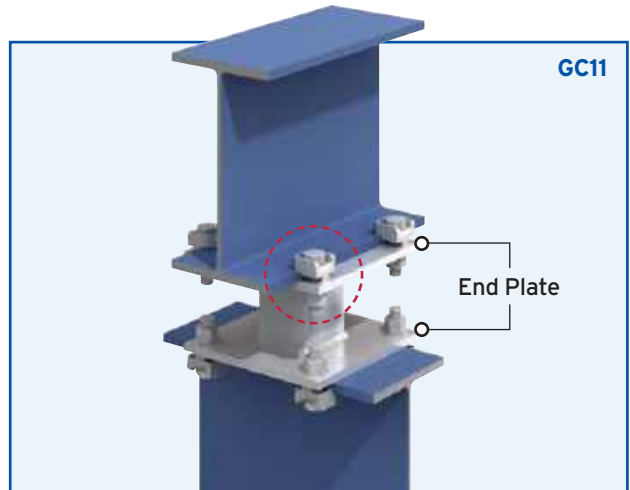
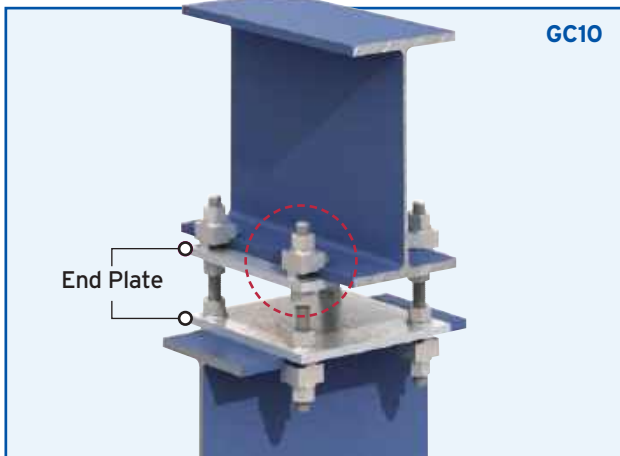
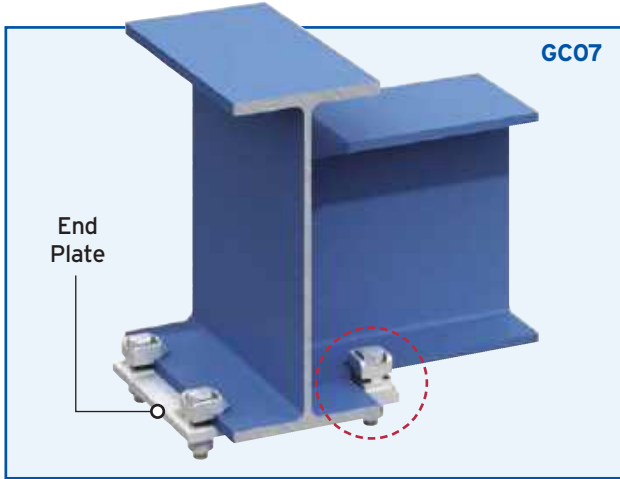

Typical Applications for Girder Clamps

Examples of popular connection arrangements are continued below:

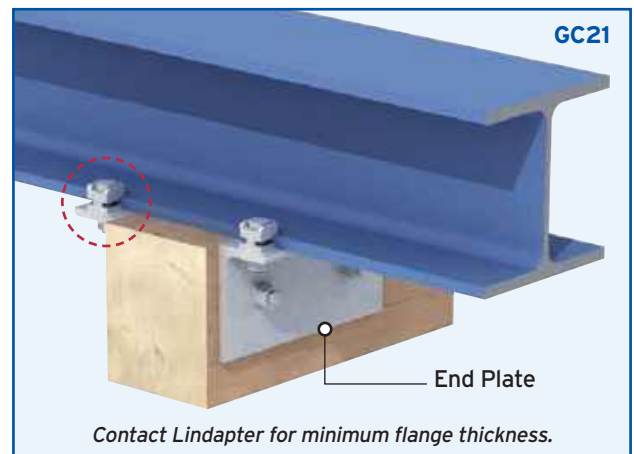
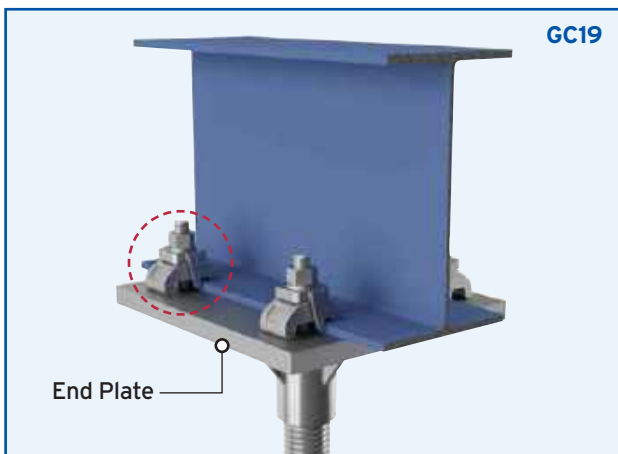
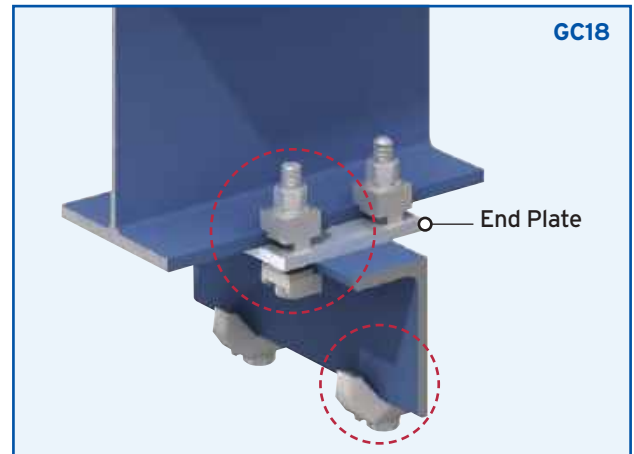
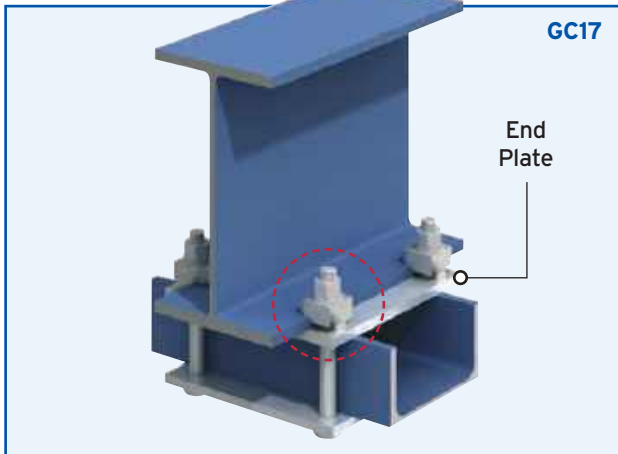
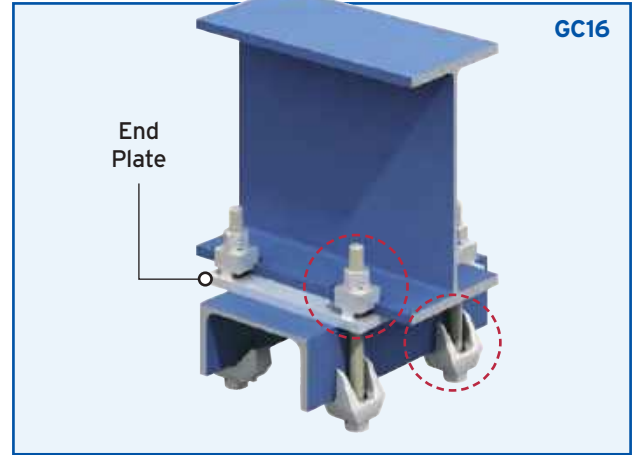
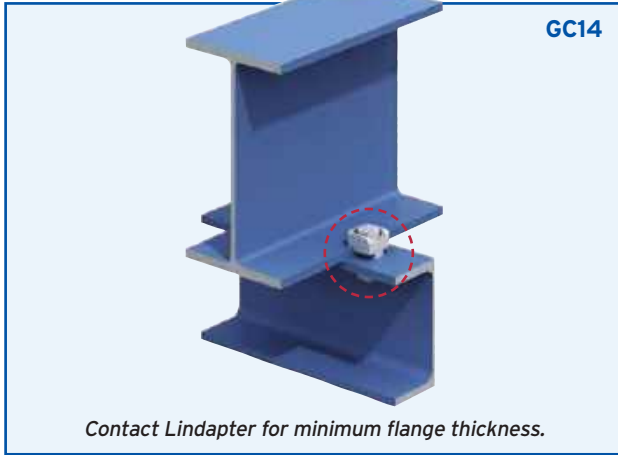
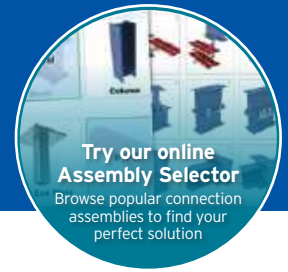

Typical Applications for Girder Clamps

More examples of popular connection assemblies are shown below:

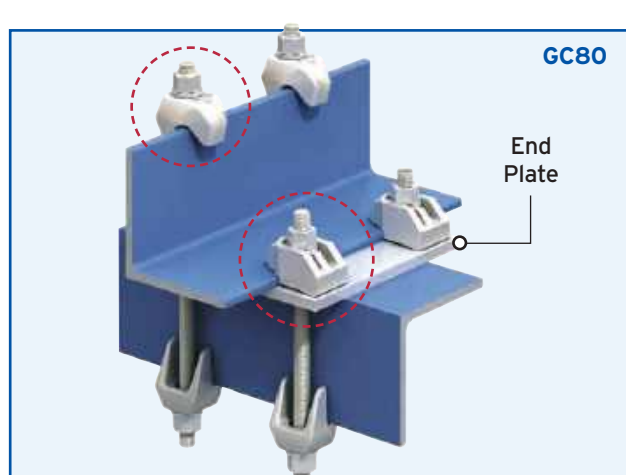
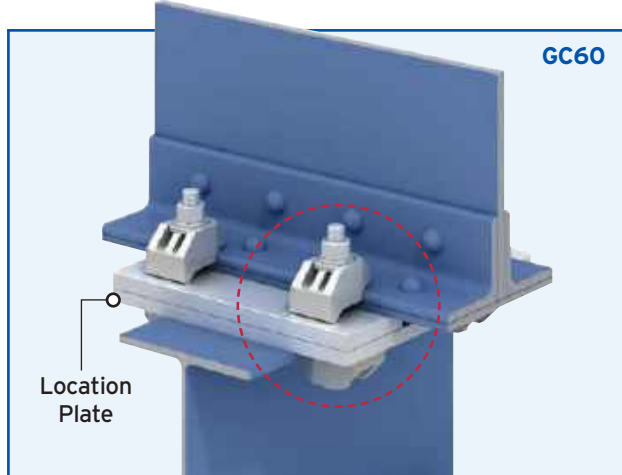
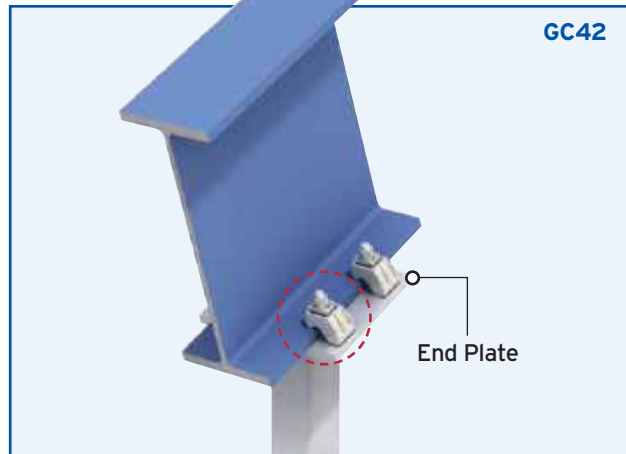
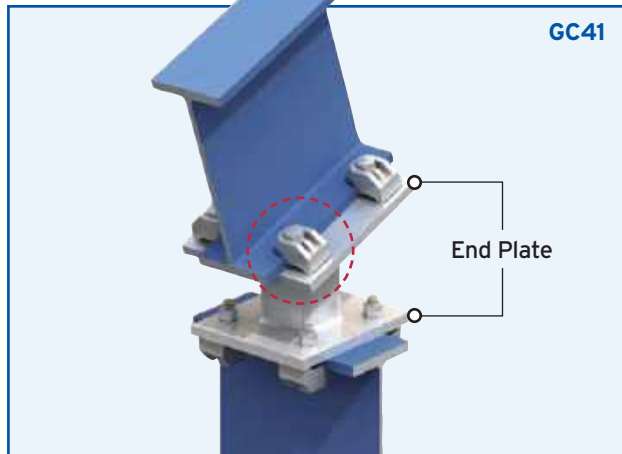
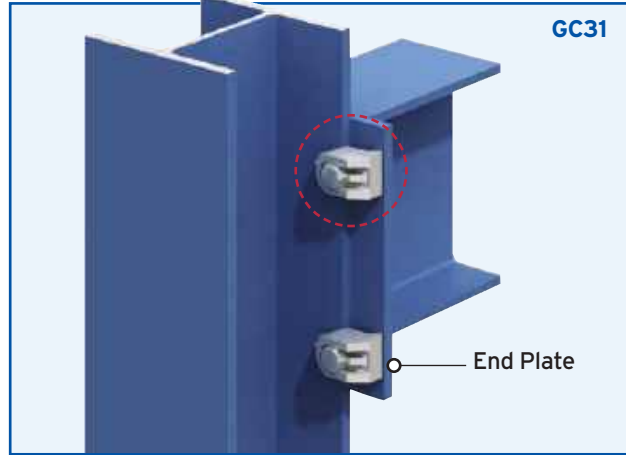
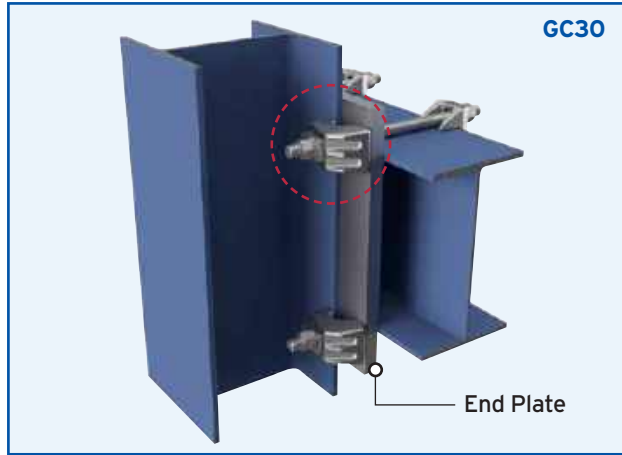

GIRDER CLAMPS

LIFTING POINTS

HOLLO-BOLT

FLOOR CONNECTIONS

PIPE SUPPORTS

FAQS & CASE STUDIES

Typical Applications for Girder Clamps

Examples of popular connection arrangements are continued below. Please contact Lindapter to discuss your connection requirement.

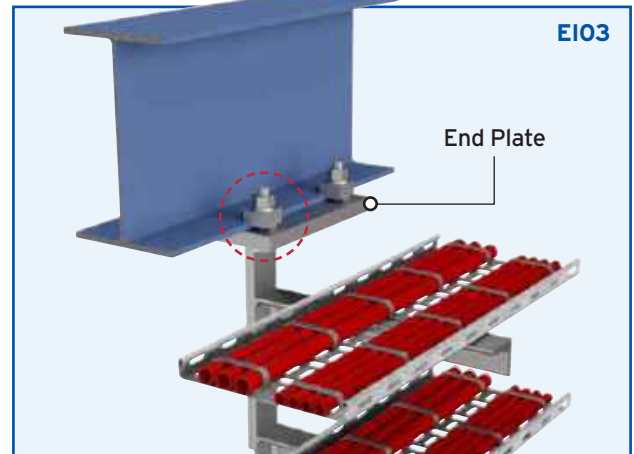
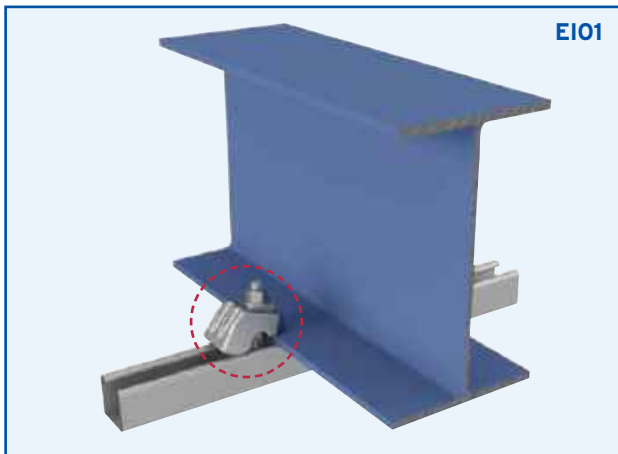
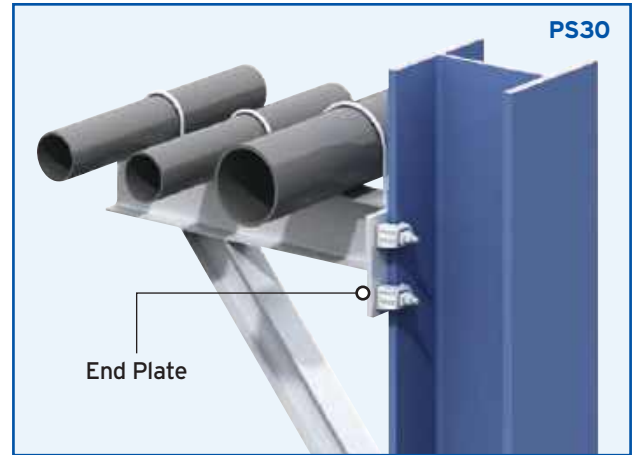
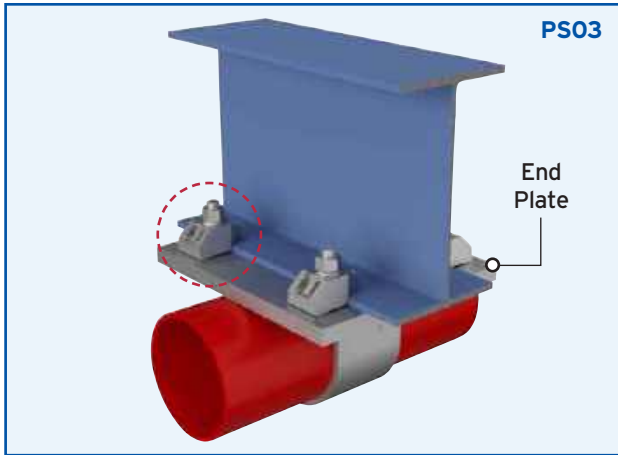
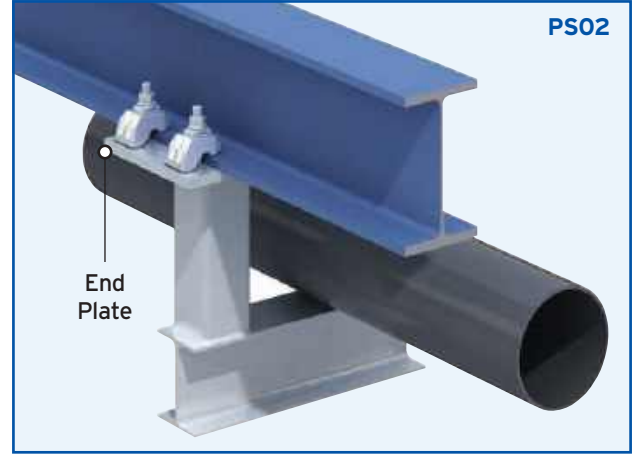
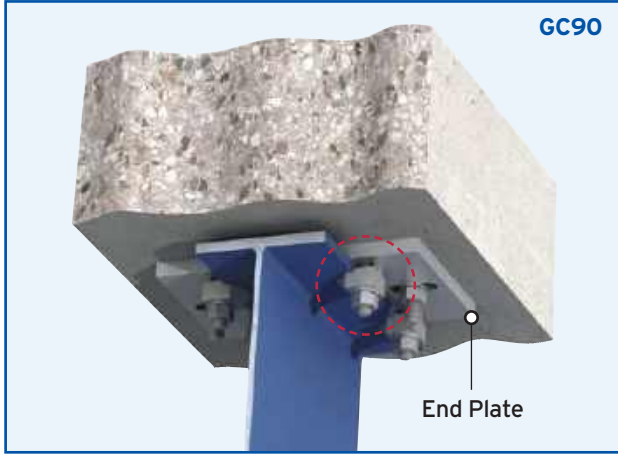

GIRDER CLAMPS
LIFTING POINTS
HOLLO-BOLT
FLOOR CONNECTIONS
PIPE SUPPORTS
FAQS & CASE STUDIES

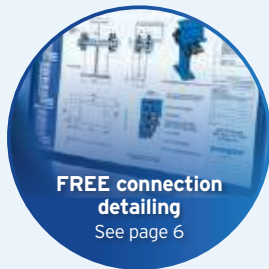

The versatile Type ALP not only provides lateral adjustability, it also adjusts to suit different beam sizes and the orientation of the lift (see page 46).

Lifting Points

Lindapter's lifting points are used in a variety of industries to support the lifting and rigging of heavy equipment. Applications vary from suspending overhead audio-visual kit in theaters to lifting drilling risers onto offshore oil platforms.

**Type ALP
(Standard)**
page 46



**Type LP
(Custom)**
page 47



Lifting Point Configuration

Lindapter manufactures Lifting Points that are configured with adjustable, high strength components to suit heavy loads up to 45,000lbs SWL. Take advantage of Lindapter's free connection detailing for advice on the best solution for your connection.

Quick and easy to install

Step 1

Offer the pre-assembled location plate up to the beam ensuring it is positioned centrally to it.



Step 2

Assemble the clamps and tighten to the recommended torque.

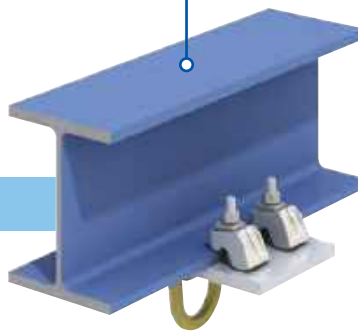

Watch the installation video at www.Lindapter.com

6 reasons to use

- ✓ Quick and easy to install using standard hand tools.
- ✓ Easy to align and reposition.
- ✓ Maximum safe working load up to 45,000lbs (Type LP).
- ✓ For parallel and tapered flanges up to 10°.
- ✓ Utilizes ICC-ES approved Lindapter clamps.
- ✓ Free Connection Detailing available.

Email your connection details to support@Lindapter.com and Lindapter's experienced Engineers will do the rest!

STANDARD

Type ALP

Ideal for most applications up to 6,600lbs, this assembly self-adjusts to suit a range of flange thicknesses. For further convenience, the slotted holes in the location plate allow the clamp to adapt to different beam widths, often allowing contractors to use just one type of lifting point throughout a project. Lindapter's standard lifting point is immediately available off-the-shelf.

See the Type ALP and its components in more detail on [page 46](#).



CUSTOM

Type LP

For large steel sections or loads up to 45,000lbs, Lindapter manufactures custom-made solutions for specific application requirements. Whatever the application, Lindapter's durable products are valued for their quality and reliability, and provide contractors with a safe, quick and convenient lifting system.

See the Type LP and its components in more detail on [page 47](#).



Type ALP

Lindapter's standard rigging and lifting solution adjusts to suit the beam width, flange thickness and orientation of the lift. Safely supports loads up to 6,600lbs.

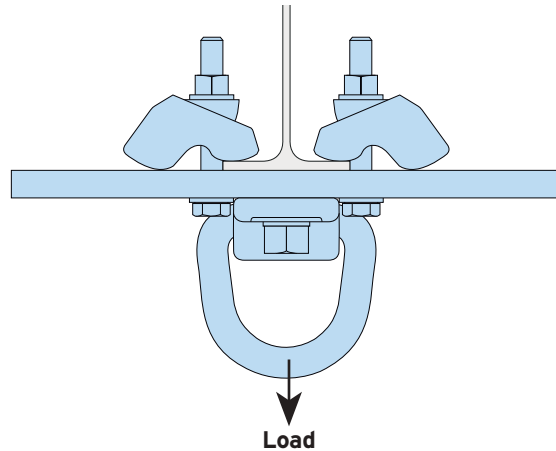
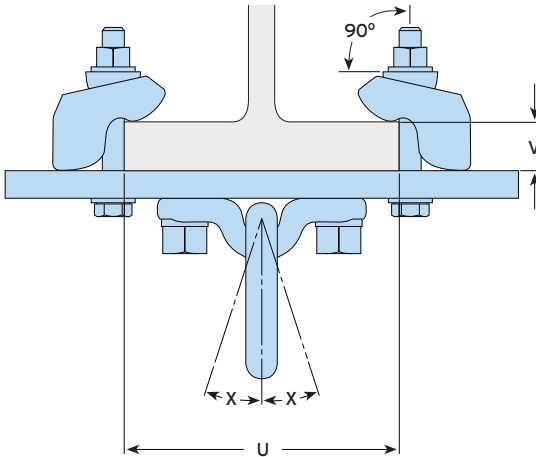
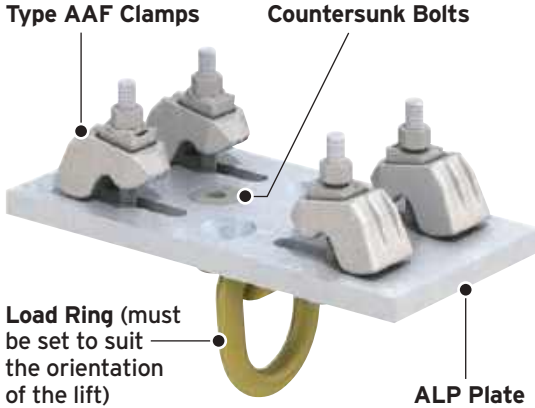

- Available 'off-the-shelf' with a safe working load up to 6,600lbs.
- Adjusts to fit different sized beams and can be easily repositioned.
- Suitable for parallel and tapered beams up to and including 10°.
- Large load ring can be repositioned at 90° to suit the orientation of the lift.

- Suitable for supporting the lifting and rigging of equipment only.
- The ALP assembly must be regularly inspected for signs of wear or damage, in accordance with the standards / regulations of the country of use.
- Static Safe Working Load values are subject to the capacity of the supporting sections. Please refer to the ALP user guide for guidance.

Material: Type AAF clamps (low temperature SG iron, hot dip galvanized), Location Plate (mild steel or hot dip galvanized) and Load Ring (forged steel, painted).

Product Code	Torque Figures*				Clamping Range		Safe Working Loads (FOS 4:1) lbs	Max Angle of Load X
	Load Ring Countersunk Bolts		Type AAF Set Screws		Flange Thickness ²⁾ V	Beam Width U		
	10.9 Bolt ¹⁾	Torque ft lb	8.8 Bolt ¹⁾	Torque ft lb				
LALP 3T-1	M16 (5/8")	74	M12 (1/2")	66	3/16" - 1"	2 3/4" - 8 1/4"	6600	18°
LALP 3T-2	M16 (5/8")	74	M12 (1/2")	66	3/16" - 1"	7 1/2" - 13"	6600	18°
LALP 3T-3	M16 (5/8")	74	M12 (1/2")	66	3/16" - 1"	12 3/16" - 17 3/4"	6600	18°

1) Metric bolts, nearest imperial / UNC equivalent shown in brackets.
 2) Packing pieces can be used to increase the clamping range. Please contact Lindapter Technical Support for more details.
 * Torque figures based on fasteners in an unlubricated condition. For further information see page 78.

GIRDER CLAMPS
LIFTING POINTS
HOLLO-BOLT
FLOOR CONNECTIONS
PIPE SUPPORTS
FAQS & CASE STUDIES

Type LP

Utilizing Lindapter's high strength Type AF or AAF clamps for heavy loads, the Type LP is available in custom configurations up to 45,000lbs SWL.

LP4 (up to 10,000lbs SWL)

Lifting Point with 4 Type AF or AAF clamps

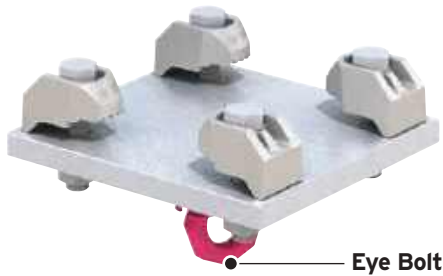

Eye Bolt

LP6 (up to 22,500lbs SWL)

Lifting Point with 6 Type AF or AAF clamps

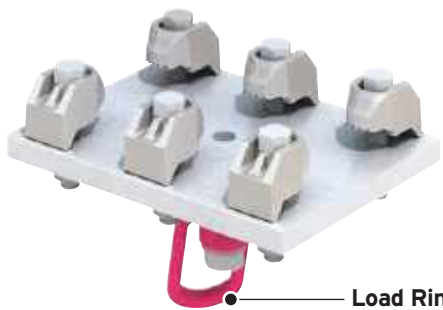

Load Ring



**CUSTOM
SOLUTION**

The Type LP can be supplied with either an Eye Bolt or Load Ring. Please state your requirement when ordering.

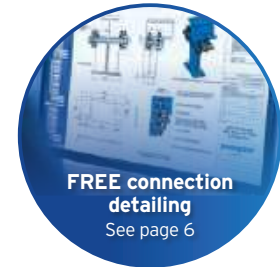

- ▶ Lifting Points must be regularly inspected for signs of wear or damage, in accordance with the standards / regulations of the country of use.
- ▶ Static Safe Working Loads are subject to the capacity of the supporting section.

Custom configurations up to 45,000lbs are also available

Lindapter manufactures customized Lifting Points to meet individual requirements, two examples are shown on the right. These custom connections are designed to specific application requirements, such as vertical loads, loads at an angle and orientation of up to 360°. The product designation, i.e. LP(#) determines the number of Type AF or AAF clamps.

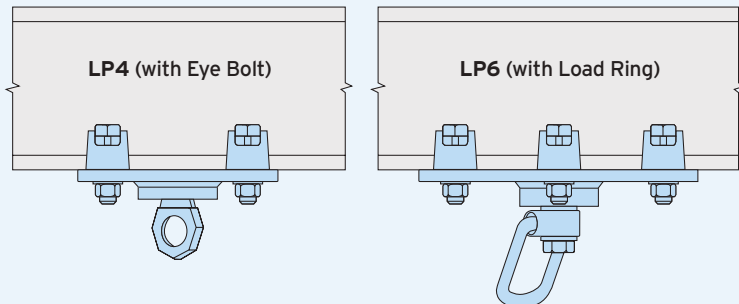

For example, the LP6 has six M24 (1") Type AF clamps to create a Safe Working Load of up to 22,500lbs (4:1 Factor of Safety). Provide details of the loading, orientation, angle and beam dimensions and Lindapter's team of Engineers will detail a connection solution to suit your needs.



Hollo-Bolt™
Plug-In Tool
available in
Tekla Warehouse

- ✓ Accurate detailing of Hollo-Bolt
- ✓ Efficient, time-saving tool
- ✓ Incorporate into BIM models

Download the plug-in from www.tekla.com



Hollo-Bolt™

Lindapter's expansion bolts require installation access to only one side of the Hollow Structural Section (HSS), and offer a faster alternative to welding or through-bolting, enabling contractors to reduce construction time and labor costs.

Hollo-Bolt™
pages 49 - 56



Hollo-Bolt™
pages 57 - 63



Drilling & Installation
pages 64 - 65



Hollo-Bolt™

Installation is quickly carried out by inserting into pre-drilled steel and tightening with a torque wrench. Recognized in the AISC Steel Construction Manual and approved by ICC-ES, see pages 57 - 63 for details. Fire-resistance rated for up to 120 minutes, F(120).

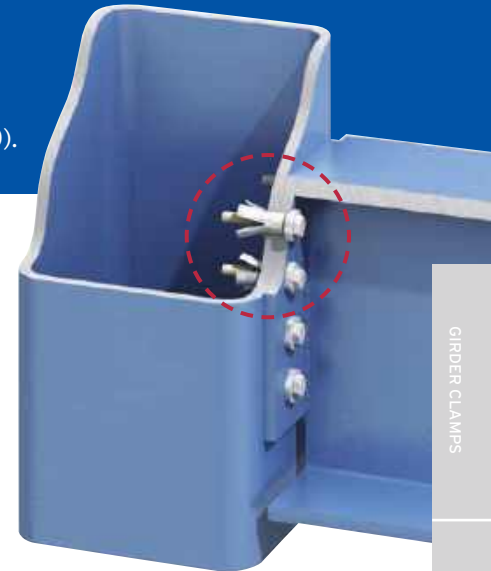

Code Compliance					
✓IBC	✓IRC	✓CBC	✓CRC	✓LABC	✓LARC

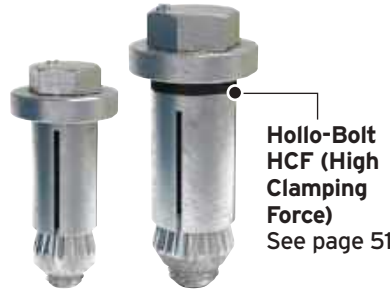

Hollo-Bolt HCF (High Clamping Force)
See page 51

Hollo-Bolt is ICC-ES for all Seismic Design Categories A through F, in compliance with the International Building Code.

- Fast, cost saving installation from one side.
- For square, rectangular and circular hollow sections.
- High resistance to tensile and shear loads.
- High Clamping Force design (sizes 5/8" and 3/4").

- Carbon steel Hexagonal Head Hollo-Bolts have been independently evaluated for fatigue resistance per AISC 360 Appendix 3.
- Carbon Steel Hexagonal Head Hollo-Bolts have been independently fire tested per ASTM E-119.
- Low temperature tested to -50°F (carbon steel variants).
- Hollo-Bolt plug-in tool available in Tekla Warehouse.

Hollo-Bolt Options

Hollo-Bolts are available in a range of head types for a variety of architectural finishes.

KEY	✓ Standard Option	✓ Available on request
-----	-------------------	------------------------

		Head Variants		
		HEXAGONAL Normal visible protrusion	COUNTERSUNK Minimal visible protrusion	FLUSH FIT Zero visible protrusion
	Sizes Available			
Core Bolt Ø	5/16"	✓ Fire Tested	✓	✓
	3/8"	✓ Fire Tested	✓	✓
	1/2"	✓ Fire Tested	✓	✓
	5/8" HCF (High Clamping Force)	✓ Fire Tested	✓	-
	3/4" HCF (High Clamping Force)	✓ Fire Tested	-	-
Carbon Steel with finish	Corrosion Protection			
	Zinc Plated + JS500	✓ Fire Tested	✓	✓
	Hot Dip Galvanized	✓ Fire Tested	-	-
	Sheraplex	✓ Fire Tested	✓	✓
	Stainless Steel (316 equivalent)	✓	✓	✓

➤ Carbon steel Hexagonal Head Hollo-Bolts have been independently fire tested under tensile and shear loading with simultaneous exposure to standard fire conditions in accordance with ASTM E-119 for 120 minutes. For load data contact Lindapter.

Sizes 5/8" and 3/4", known as the Hollo-Bolt HCF, feature a High Clamping Force mechanism to produce three times more clamping force than the same sized product without the mechanism. See page 51 for more information.

GIRDER CLAMPS
LIFTING POINTS
HOLLO-BOLT
FLOOR CONNECTIONS
PIPE SUPPORTS
FAOS & CASE STUDIES

Hollo-Bolt Options

Two versions are available; the original design for general hollow section connections (see below) and the larger sized High Clamping Force (HCF) for higher strength structural connections (see page 51).

Hollo-Bolt™ (sizes 5/16", 3/8" and 1/2")

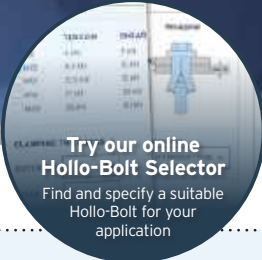
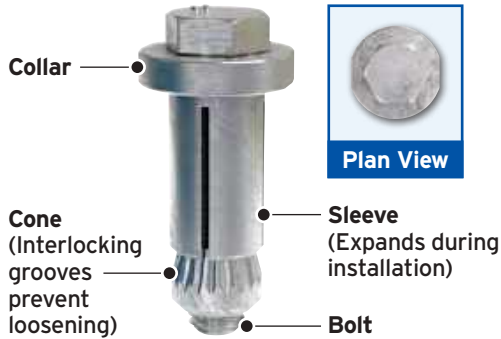

The Connection Concept

A typical connection is made by inserting the Hollo-Bolt into the pre-drilled holes of the fixture and hollow section. As the bolt head is tightened, the cone is pulled up the bolt thread, causing the sleeve to expand until the cone locks the sleeve against the hollow section's inner wall.

At full tightening torque, a clamping force is established between the fixture and the steel section to form a secure connection. Once installed, only the head and the collar are visible.

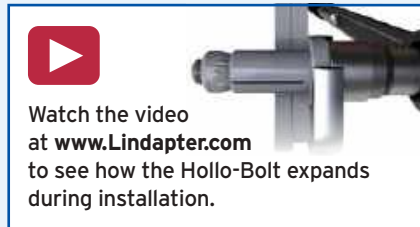
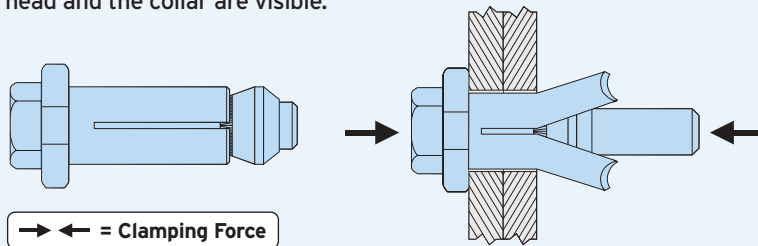

Case Study: Tobin Memorial Bridge (Boston, MA)

50,000 Hollo-Bolts provided a quick, secure, and easy to install solution for the refurbishment of the bridge, which is over 11,000ft long.

A solution was required for repairs and improvements to safety walkways used by maintenance personnel.

Checker plate covers were formed off-field into "S" shapes and then installed onto the safety curbs using 5/16" and 1/2" stainless steel Hollo-Bolts.

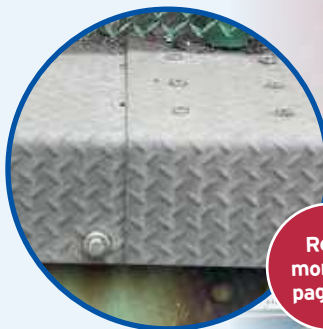

GIRDER CLAMPS

LIFTING POINTS

HOLLO-BOLT

FLOOR CONNECTIONS

PIPE SUPPORTS

FAQS & CASE STUDIES

Hollo-Bolt HCF

The larger 5/8" and 3/4" Hollo-Bolts are optimized for high strength structural connections and feature a High Clamping Force mechanism for superior performance.

Hollo-Bolt™ HCF (sizes 5/8" and 3/4")

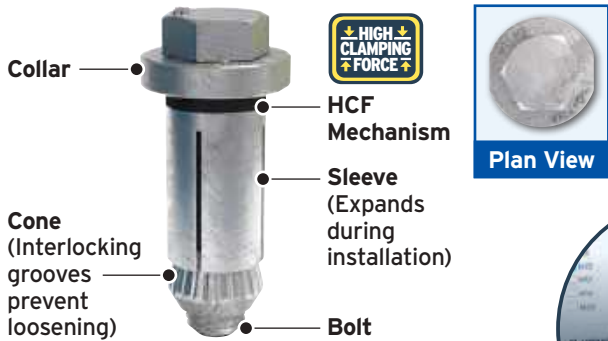

Try our online **Hollo-Bolt Selector**
Find and specify a suitable Hollo-Bolt for your application

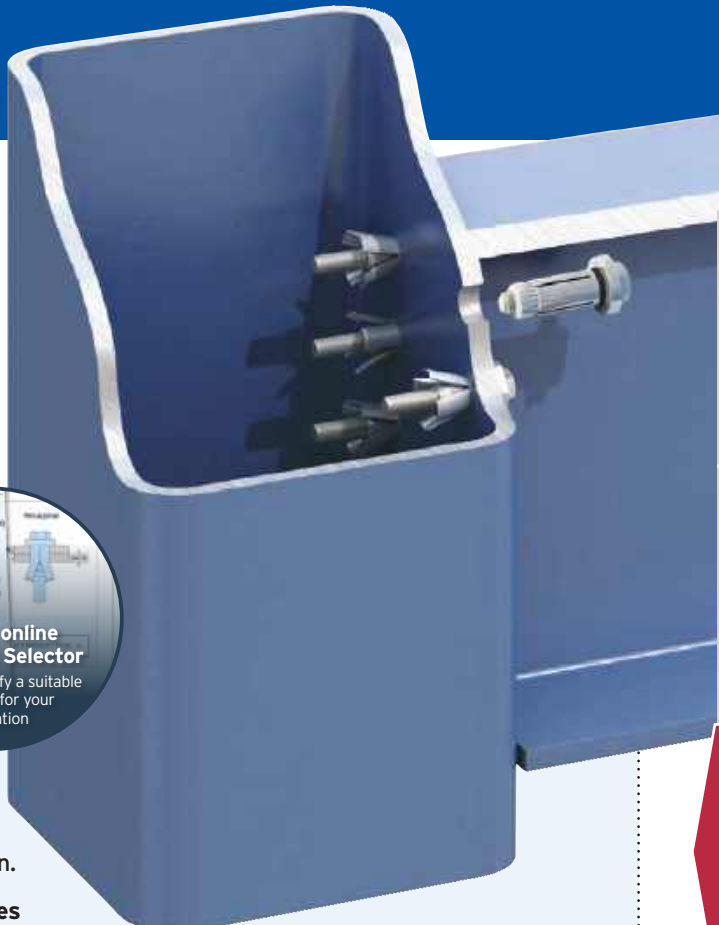

GIRDER CLAMPS
LIFTING POINTS
HOLLO-BOLT

The Connection Concept

The HCF mechanism consists of a special rubber washer that compresses during installation to significantly increase the clamping force between the connecting steel, thereby reducing displacement to achieve a higher strength connection.

The typical clamping force of Hollo-Bolt HCF is over **three times higher** than the same sized product without the mechanism.

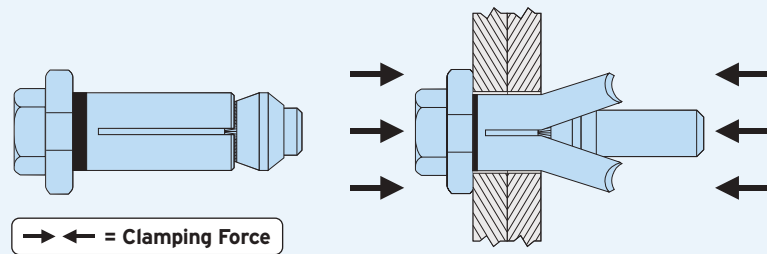

Watch the video at www.Lindapter.com to see how the High Clamping Force mechanism increases clamping force.

FLOOR CONNECTIONS

Case Study: Wilshire Grand Center (Los Angeles, CA)

3,000 Hollo-Bolts were used to connect primary steel tubes (HSS), which form the curved canopy structure of this skyscraper in Los Angeles.

They were installed from just one side, rapidly achieving discreet splice connections without drilling or welding in the field.

The cost-effective installation did not require specialist equipment or labor and reduced the amount of work at height in comparison to welding or through-bolting.



Read more on page 92

PIPE SUPPORTS

FAOS & CASE STUDIES

Fillers for Hollo-Bolt applications

Fillers or shims are steel strips or plates used in bolted connections to fill gaps in the connecting steel. For guidance regarding the use of fillers/shims in Bolted-Bearing Type connections please refer to AISC 360 - Specification for Structural Steel Buildings Section J5 fillers.

GIRDER CLAMPS

LIFTING POINTS

HOLLO-BOLT

FLOOR CONNECTIONS

PIPE SUPPORTS

FAQS & CASE STUDIES

LOOSE FILLERS: SUITABLE FOR GAPS UP TO 1/4"

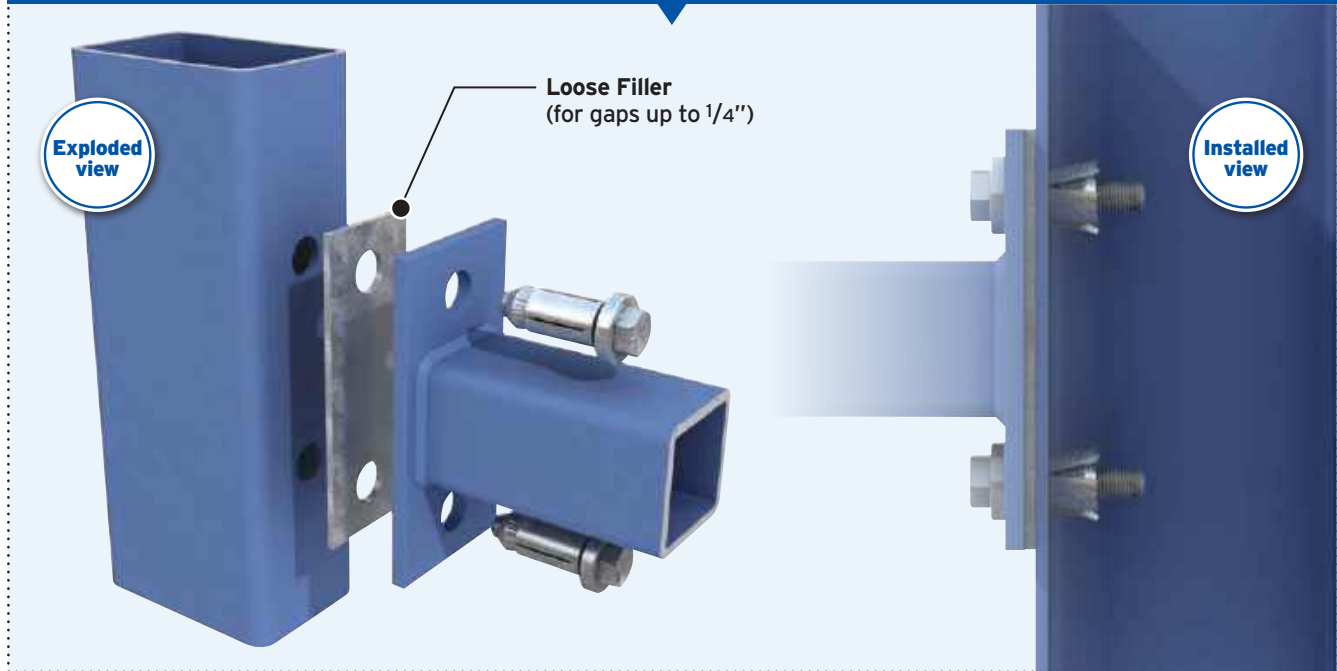

WELDED FILLERS: SUITABLE FOR GAPS GREATER THAN 1/4"

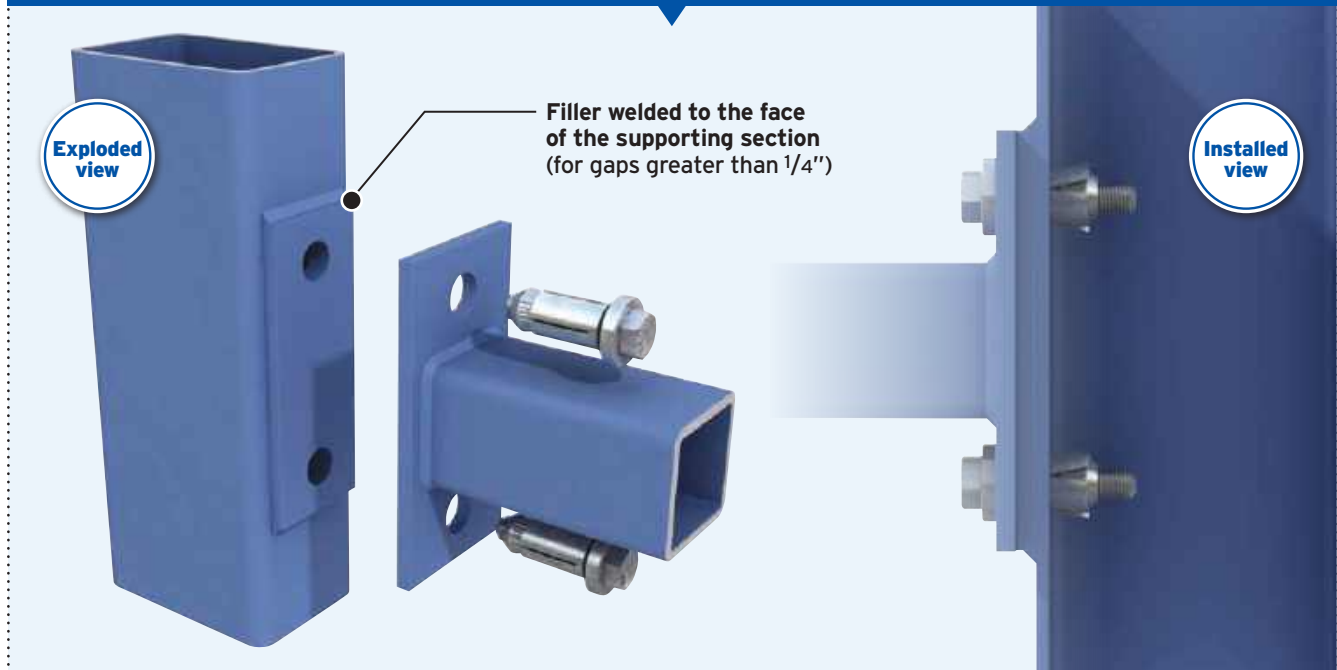

Hollo-Bolt Product Codes

Hollo-Bolts are identified by a product code made up of a series of letters and numbers. The product code decoder below explains what each part of the code denotes. When specifying Hollo-Bolts the full product code along with the finish code at the end should be used. Refer to page 49 for which sizes, head types and finishes are available.



Example Product Code

LHBM08HEX#1ZN

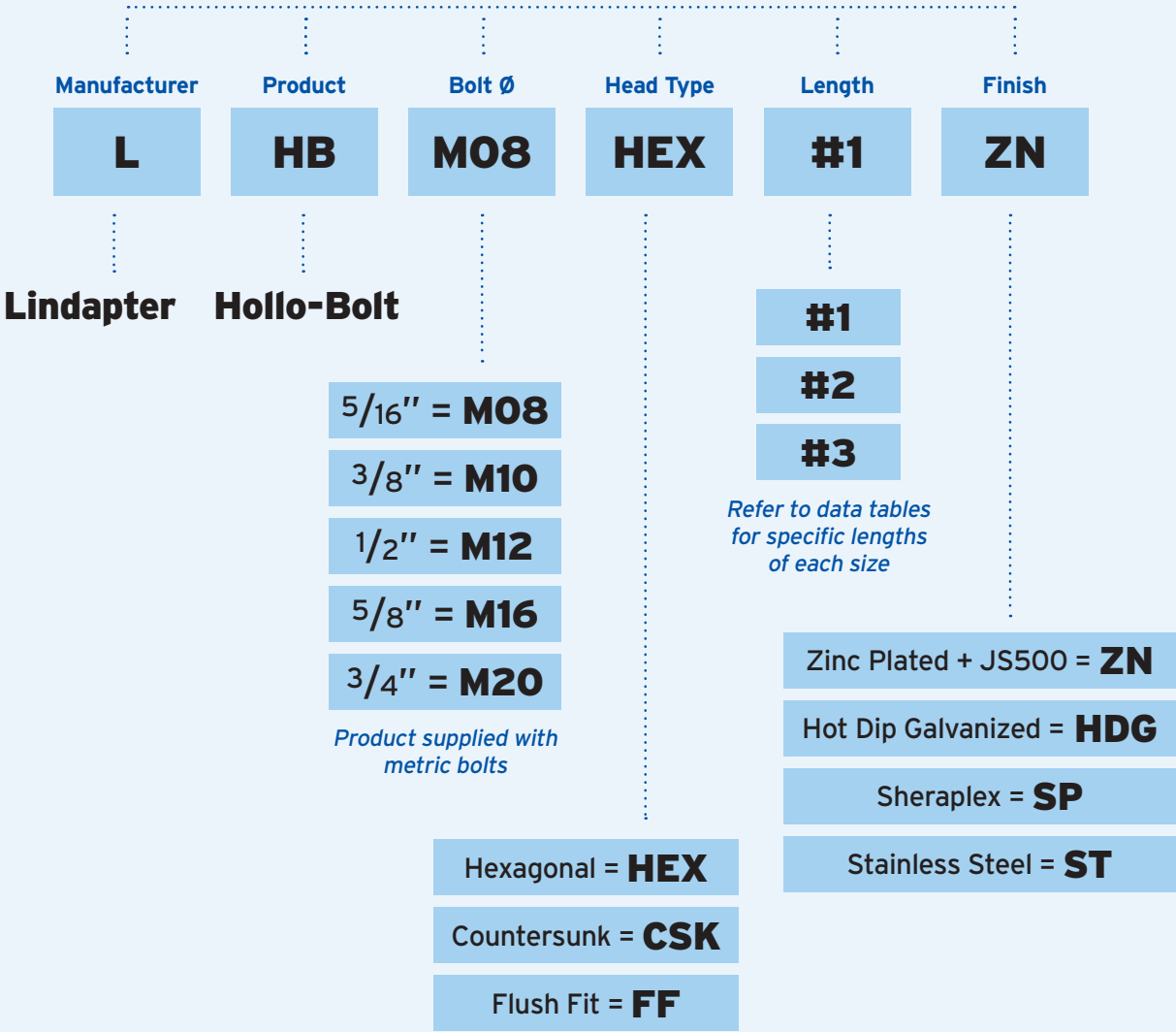

Hollo-Bolt™ Hexagonal Head Safe Working Loads



IMPORTANT: If you are designing a connection to the IBC, refer to the ICC-ES data on pages 58-59.



Evaluated for fatigue resistance per ICC-ES ESR-3330



Fire Tested per ASTM E-119



Hexagonal Head Data

(Available in sizes 5/16", 3/8", 1/2", 5/8" and 3/4")

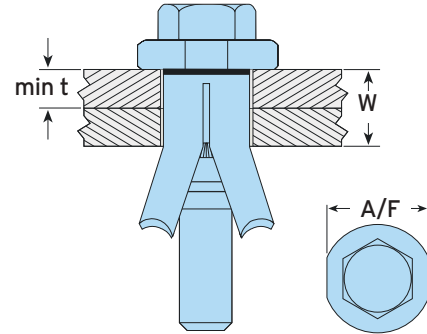
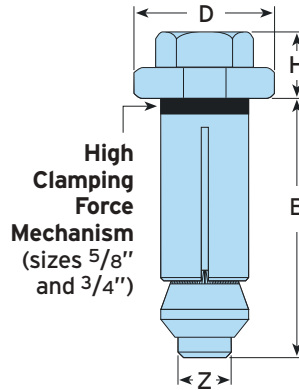
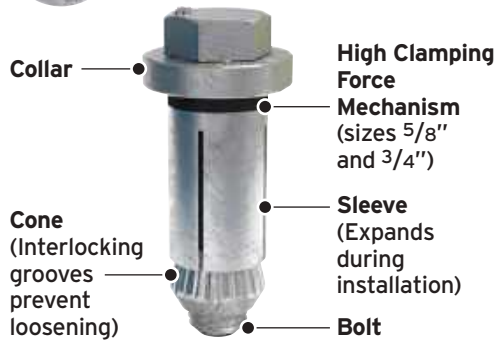

Material: Carbon steel or stainless steel (see page 49 for corrosion protection options).

HEXAGONAL HEAD DATA

Product Code	Bolt Ø Z	Height H	Length B	Clamping Thickness W	Outer Ply min t	Drill Hole Diameter Ø	Collar		Tightening Torque ft lb	Safe Working Loads (FoS 5:1)		
							Ø D	A/F		Tensile lbs	Single Shear lbs	
LHBM08HEX#1	5/16"	3/8"	13/4"	1/8" - 7/8"	-	9/16"	7/8"	3/4"	17	899	1124	
LHBM08HEX#2	5/16"	3/8"	29/16"	7/8" - 15/8"	-	9/16"	7/8"	3/4"	17	899	1124	
LHBM08HEX#3	5/16"	3/8"	33/8"	15/8" - 23/8"	-	9/16"	7/8"	3/4"	17	899	1124	
LHBM10HEX#1	3/8"	1/2"	2"	1/8" - 7/8"	-	3/4"	1 1/8"	15/16"	33	1910	2248	
LHBM10HEX#2	3/8"	1/2"	2 1/2"	7/8" - 15/8"	-	3/4"	1 1/8"	15/16"	33	1910	2248	
LHBM10HEX#3	3/8"	1/2"	3 5/16"	15/8" - 2 3/8"	-	3/4"	1 1/8"	15/16"	33	1910	2248	
LHBM12HEX#1	1/2"	9/16"	2 1/8"	1/8" - 1"	-	13/16"	1 1/4"	13/16"	59	2360	3372	
LHBM12HEX#2	1/2"	9/16"	2 7/8"	1" - 1 13/16"	-	13/16"	1 1/4"	13/16"	59	2360	3372	
LHBM12HEX#3	1/2"	9/16"	3 3/4"	1 13/16" - 2 3/4"	-	13/16"	1 1/4"	13/16"	59	2360	3372	
Hollo-Bolt HCF	LHBM16HEX#1	5/8"	3/4"	2 5/8"	1/2" - 1 1/8"	5/16"	1 1/16"	1 1/2"	17/16"	140	4720	6744
	LHBM16HEX#2	5/8"	3/4"	3 5/8"	1 1/8" - 2"	5/16"	1 1/16"	1 1/2"	17/16"	140	4720	6744
	LHBM16HEX#3	5/8"	3/4"	4 7/16"	2" - 2 13/16"	5/16"	1 1/16"	1 1/2"	17/16"	140	4720	6744
	LHBM20HEX#1	3/4"	7/8"	3 1/8"	1/2" - 15/16"	5/16"	15/16"	2"	1 13/16"	221	7868	8992
	LHBM20HEX#2	3/4"	7/8"	4 5/16"	15/16" - 2 3/8"	5/16"	15/16"	2"	1 13/16"	221	7868	8992
	LHBM20HEX#3	3/4"	7/8"	5 1/2"	2 3/8" - 3 3/8"	5/16"	15/16"	2"	1 13/16"	221	7868	8992

- Hollo-Bolts can be used on a variety of steel hollow sections and shapes. Safe working loads shown are applicable to the Hollo-Bolt only. Failure of the section could occur at a lower figure and therefore its strength should be checked by a qualified Structural Engineer. Contact Lindapter for equivalent bearing area and diameter under cone.
- Fatigue resistance testing has been performed for Carbon Steel Hollo-Bolts in accordance with AISC 360 Appendix 3. Contact our Technical Support team or refer to ESR-3330 for more information.

HOW TO SPECIFY THE FINISH TO THE PRODUCT CODE

Example Product Code

Choose your finish and add the finish code

Final Product Code

LHBM08HEX#1

Zinc Plated + JS500 **ZN** Sheraplex **SP**
 Hot Dip Galvanized **HDG** Stainless Steel **ST**

LHBM08HEX#1HDG

Hollo-Bolt™ Countersunk Head Safe Working Loads

ICC ES IMPORTANT: If you are designing a connection to the IBC, refer to the ICC-ES data on pages 60-61.



Countersunk Head Data

(Available in sizes 5/16", 3/8", 1/2" and 5/8")

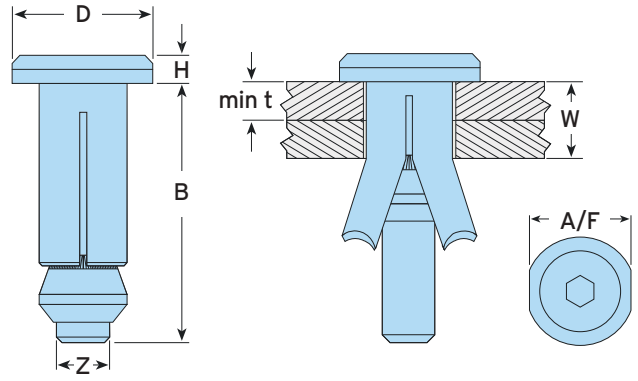
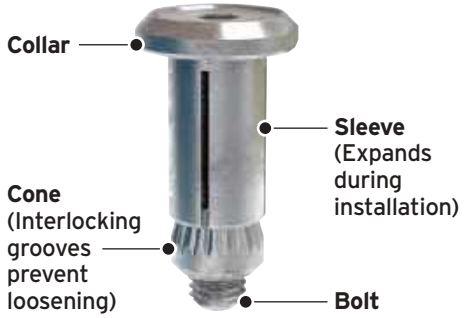

Material: Carbon steel or stainless steel (see page 49 for corrosion protection options).

COUNTERSUNK HEAD DATA												
Product Code	Bolt Ø Z	Height H	Length B	Clamping Thickness W	Outer Ply min t	Drill Hole Diameter Ø	Collar		Tightening Torque ft lb	Safe Working Loads (FoS 5:1)		
							Ø D	A/F		Tensile lbs	Single Shear lbs	
LHBM08CSK#1	5/16"	3/16"	13/4"	1/8" - 7/8"	-	9/16"	7/8"	3/4"	17	899	1124	
LHBM08CSK#2	5/16"	3/16"	29/16"	7/8" - 15/8"	-	9/16"	7/8"	3/4"	17	899	1124	
LHBM08CSK#3	5/16"	3/16"	33/8"	15/8" - 23/8"	-	9/16"	7/8"	3/4"	17	899	1124	
LHBM10CSK#1	3/8"	1/4"	13/4"	1/8" - 7/8"	-	3/4"	11/8"	15/16"	33	1910	2248	
LHBM10CSK#2	3/8"	1/4"	21/2"	7/8" - 15/8"	-	3/4"	11/8"	15/16"	33	1910	2248	
LHBM10CSK#3	3/8"	1/4"	35/16"	15/8" - 23/8"	-	3/4"	11/8"	15/16"	33	1910	2248	
LHBM12CSK#1	1/2"	1/4"	17/8"	1/8" - 1"	-	13/16"	11/4"	13/16"	59	2360	3372	
LHBM12CSK#2	1/2"	1/4"	27/8"	1" - 113/16"	-	13/16"	11/4"	13/16"	59	2360	3372	
LHBM12CSK#3	1/2"	1/4"	311/16"	113/16" - 23/4"	-	13/16"	11/4"	13/16"	59	2360	3372	
HCF LHBM16CSK#1	5/8"	5/16"	27/16"	1/2" - 11/8"	5/16"	11/16"	11/2"	17/16"	140	4720	6744	
LHBM16CSK#2	5/8"	5/16"	35/8"	11/8" - 2"	5/16"	11/16"	11/2"	17/16"	140	4720	6744	
LHBM16CSK#3	5/8"	5/16"	47/16"	2" - 213/16"	5/16"	11/16"	11/2"	17/16"	140	4720	6744	

➔ Hollo-Bolts can be used on a variety of steel hollow sections and shapes. Safe working loads shown are applicable to the Hollo-Bolt only. Failure of the section could occur at a lower figure and therefore its strength should be checked by a qualified Structural Engineer. Contact Lindapter for equivalent bearing area and diameter under cone.

HOW TO SPECIFY THE FINISH TO THE PRODUCT CODE

Example Product Code: **LHBM10CSK#1** → Choose your finish and add the finish code: Zinc Plated + JS500 **ZN**, Stainless Steel **ST**, Sheraplex **SP** → Final Product Code: **LHBM10CSK#1ST**

GIRDER CLAMPS | LIFTING POINTS | HOLLO-BOLT | FLOOR CONNECTIONS | PIPE SUPPORTS | FAOS & CASE STUDIES

Hollo-Bolt™ Flush Fit Head Safe Working Loads



IMPORTANT: If you are designing a connection to the IBC, refer to the ICC-ES data on pages 62-63.



Flush Fit Head Data

(Available in sizes 5/16", 3/8" and 1/2")

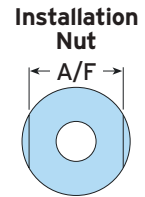
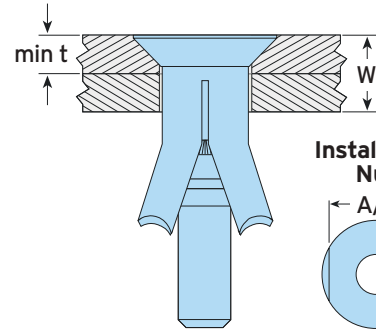
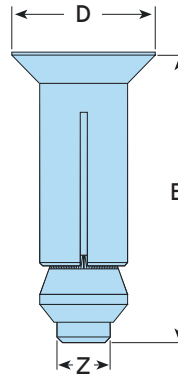
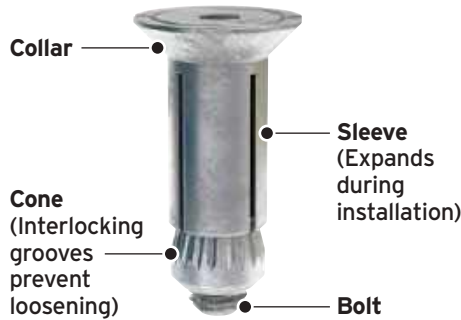

Material: Carbon steel or stainless steel (see page 49 for corrosion protection options).

FLUSH FIT DATA										
Product Code	Countersunk Bolt Ø Z	Length B	Clamping Thickness W	Outer Ply min t	Drill Hole Diameter Ø	Collar		Tightening Torque ft lb	Safe Working Loads (FoS 5:1)	
						Ø D	Installation Nut A/F		Tensile lbs	Single Shear lbs
LHBM08FF#1	5/16"	2"	3/8" - 11/16"	5/16"	9/16"	15/16"	3/4"	17	899	1124
LHBM08FF#2	5/16"	2 3/4"	1 1/16" - 1 3/4"	5/16"	9/16"	15/16"	3/4"	17	899	1124
LHBM08FF#3	5/16"	3 9/16"	1 3/4" - 2 1/2"	5/16"	9/16"	15/16"	3/4"	17	899	1124
LHBM10FF#1	3/8"	2"	1/2" - 1 1/16"	3/8"	3/4"	1 3/16"	15/16"	33	1910	2248
LHBM10FF#2	3/8"	2 3/4"	1 1/16" - 1 3/4"	3/8"	3/4"	1 3/16"	15/16"	33	1910	2248
LHBM10FF#3	3/8"	3 9/16"	1 3/4" - 2 1/2"	3/8"	3/4"	1 3/16"	15/16"	33	1910	2248
LHBM12FF#1	1/2"	2 3/16"	1/2" - 1 3/16"	3/8"	13/16"	15/16"	1 3/16"	59	2360	3372
LHBM12FF#2	1/2"	3 1/8"	1 3/16" - 2 1/32"	3/8"	13/16"	15/16"	1 3/16"	59	2360	3372
LHBM12FF#3	1/2"	4"	2 1/32" - 2 7/8"	3/8"	13/16"	15/16"	1 3/16"	59	2360	3372

➤ Hollo-Bolts can be used on a variety of steel hollow sections and shapes. Safe working loads shown are applicable to the Hollo-Bolt only. Failure of the section could occur at a lower figure and therefore its strength should be checked by a qualified Structural Engineer. Contact Lindapter for equivalent bearing area and diameter under cone.

HOW TO SPECIFY THE FINISH TO THE PRODUCT CODE

Example Product Code

Choose your finish and add the finish code

Final Product Code

LHBM12FF#3

Zinc Plated + JS500 ZN

Stainless Steel ST

Sheraplex SP

LHBM12FF#3ZN

“

We recommend using Hollo-Bolts due to the ICC-ES approved capacities for use in **all** Seismic Design Categories.

”

John S. McDonald, Principal at Catena Consulting Engineers
Project: Wilshire Grand Center, CA (see the case study on page 92)



ICC-ES Approved Hollo-Bolt™

The following pages are for use by Engineers designing a connection as per AISC 360, AISC 341 and ASCE/SEI 7 as referenced by the locally adopted building code. To comply with ICC-ES please also refer to our Evaluation Report ESR 3330 and the Special Inspection Document which can be found on our website.



**Hollo-Bolt™
Hexagonal
Head**
pages 58 - 59



**Hollo-Bolt™
Countersunk
Head**
pages 60 - 61



**Hollo-Bolt™
Flush Fit
Head**
pages 62 - 63



Hollo-Bolt™ Hexagonal Head (data for applications requiring ICC approval)

ICC ES ESR-3330		Evaluated for fatigue resistance per ICC-ES ESR-3330	Fire Tested per ASTM E-119	Code Compliance	✓ IBC	✓ IRC
				✓ CBC	✓ CRC	✓ LABC

LRFD design strength and ASD allowable strength

LRFD and ASD strengths (taken from ESR-3330) are to be used when designing a connection per AISC 360, AISC 341, and ASCE/SEI 7 as referenced by the locally adopted building code.

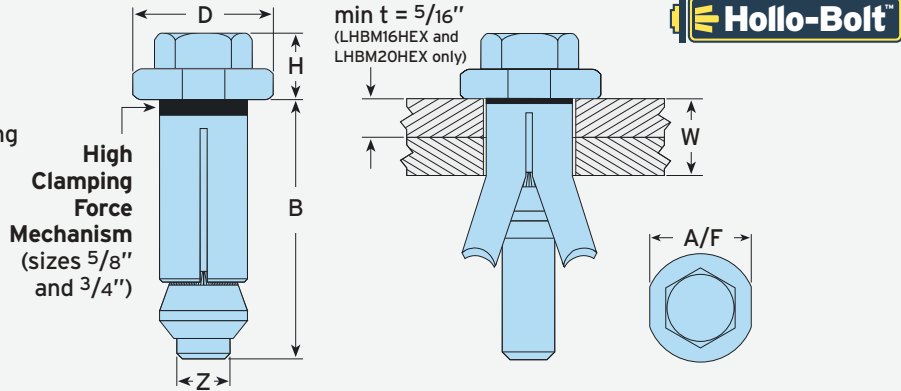

Data for Zinc + JS500, HDG and Sheraplex

Material: Carbon steel.

Product Code	Bolt Ø Z	Clamping Range W	Length B	Height H	Drill Hole Diameter Ø	Collar		Tightening Torque ft lb	Allowable Loading							
						Ø D	A/F		Static and Wind Loads				Seismic Loads			
									Tensile lbs	Shear lbs	Tensile lbs	Shear lbs	Tensile lbs	Shear lbs	Tensile lbs	Shear lbs
LHBM08HEX#1	5/16"	1/4" - 7/8"	1 3/4"	3/8"	9/16"	7/8"	3/4"	17	3780	3220	2340	2000	3310	2680	2045	1670
LHBM08HEX#2	5/16"	7/8" - 1 5/8"	2 9/16"	3/8"	9/16"	7/8"	3/4"	17	3780	3220	2340	2000	3310	2680	2045	1670
LHBM08HEX#3	5/16"	1 5/8" - 2 3/8"	3 3/8"	3/8"	9/16"	7/8"	3/4"	17	3780	3220	2340	2000	3310	2680	2045	1670
LHBM10HEX#1	3/8"	5/16" - 7/8"	2"	1/2"	3/4"	1 1/8"	1 5/16"	33	6160	5490	3820	3420	5490	4570	3400	2830
LHBM10HEX#2	3/8"	7/8" - 1 5/8"	2 1/2"	1/2"	3/4"	1 1/8"	1 5/16"	33	6160	5490	3820	3420	5490	4570	3400	2830
LHBM10HEX#3	3/8"	1 5/8" - 2 3/8"	3 5/16"	1/2"	3/4"	1 1/8"	1 5/16"	33	6160	5490	3820	3420	5490	4570	3400	2830
LHBM12HEX#1	1/2"	5/16" - 1"	2 1/8"	9/16"	13/16"	1 1/4"	1 3/16"	59	8550	7490	5310	4680	7470	6250	4630	3890
LHBM12HEX#2	1/2"	1" - 1 13/16"	2 7/8"	9/16"	13/16"	1 1/4"	1 3/16"	59	8550	7490	5310	4680	7470	6250	4630	3890
LHBM12HEX#3	1/2"	1 13/16" - 2 3/4"	3 3/4"	9/16"	13/16"	1 1/4"	1 3/16"	59	8550	7490	5310	4680	7470	6250	4630	3890
LHBM16HEX#1	5/8"	1/2" - 1 1/8"	2 5/8"	3/4"	1 1/16"	1 1/2"	1 7/16"	140	13900	11600	8640	7290	13300	9780	8270	6090
LHBM16HEX#2	5/8"	1 1/8" - 2"	3 5/8"	3/4"	1 1/16"	1 1/2"	1 7/16"	140	13900	11600	8640	7290	13300	9780	8270	6090
LHBM16HEX#3	5/8"	2" - 2 13/16"	4 1/2"	3/4"	1 1/16"	1 1/2"	1 7/16"	140	13900	11600	8640	7290	13300	9780	8270	6090
LHBM20HEX#1	3/4"	1/2" - 1 5/16"	3 1/8"	7/8"	1 5/16"	2"	1 13/16"	221	20000	18400	12400	11500	19400	15300	12000	9560
LHBM20HEX#2	3/4"	1 5/16" - 2 3/8"	4 5/16"	7/8"	1 5/16"	2"	1 13/16"	221	20000	18400	12400	11500	19400	15300	12000	9560
LHBM20HEX#3	3/4"	2 3/8" - 3 3/8"	5 1/2"	7/8"	1 5/16"	2"	1 13/16"	221	20000	18400	12400	11500	19400	15300	12000	9560

➤ Hollo-Bolts can be used on a variety of steel hollow sections and shapes. Limit States of the section, could occur at a lower figure and therefore its strength should be checked by a qualified Structural Engineer. Contact Lindapter for equivalent bearing area and diameter under cone.

➤ Refer to ESR-3330 and Lindapter's Special Inspection Document for details of connection design, installation and conditions of use.

HOW TO SPECIFY THE FINISH TO THE PRODUCT CODE

Example Product Code	Choose your finish and add the finish code	Final Product Code
LHBM08HEX#1_____	Zinc Plated + JS500 ZN Sheraplex SP Hot Dip Galvanized HDG Stainless Steel ST	LHBM08HEX#1HDG

GIRDER CLAMPS

LIFTING POINTS

HOLLO-BOLT

FLOOR CONNECTIONS

PIPE SUPPORTS

FAQS & CASE STUDIES

Hollo-Bolt™ Hexagonal Head (data for applications requiring ICC approval)

Data for Stainless Steel

Product Code	Bolt Ø	Clamping Range	Length	Height	Drill Hole Diameter Ø	Collar		Tightening Torque	Allowable Loading								
						Ø	D		Static and Wind Loads				Seismic Loads				
									Tensile	Shear	Tensile	Shear	Tensile	Shear	Tensile	Shear	
Z	W	B	H				A/F	ft lb	lbs	lbs	lbs	lbs	lbs	lbs	lbs	lbs	
LHBM08HEX#1ST	5/16"	1/4" - 7/8"	13/4"	3/8"	9/16"	7/8"	3/4"	17	5980	6430	3730	4020	4790	4770	2990	2970	
LHBM08HEX#2ST	5/16"	7/8" - 15/8"	29/16"	3/8"	9/16"	7/8"	3/4"	17	5980	6430	3730	4020	4790	4770	2990	2970	
LHBM08HEX#3ST	5/16"	15/8" - 23/8"	33/8"	3/8"	9/16"	7/8"	3/4"	17	5980	6430	3730	4020	4790	4770	2990	2970	
LHBM10HEX#1ST	3/8"	5/16" - 7/8"	2"	1/2"	3/4"	1 1/8"	15/16"	33	9730	10930	6070	6830	8120	9220	5080	5760	
LHBM10HEX#2ST	3/8"	7/8" - 15/8"	2 1/2"	1/2"	3/4"	1 1/8"	15/16"	33	9730	10930	6070	6830	8120	9220	5080	5760	
LHBM10HEX#3ST	3/8"	15/8" - 23/8"	3 5/16"	1/2"	3/4"	1 1/8"	15/16"	33	9730	10930	6070	6830	8120	9220	5080	5760	
LHBM12HEX#1ST	1/2"	5/16" - 1"	2 1/8"	9/16"	13/16"	1 1/4"	13/16"	59	12190	13440	7620	8430	10250	12250	6410	7640	
LHBM12HEX#2ST	1/2"	1" - 1 13/16"	2 7/8"	9/16"	13/16"	1 1/4"	13/16"	59	12190	13440	7620	8430	10250	12250	6410	7640	
LHBM12HEX#3ST	1/2"	1 13/16" - 2 3/4"	3 3/4"	9/16"	13/16"	1 1/4"	13/16"	59	12190	13440	7620	8430	10250	12250	6410	7640	
Hollo-Bolt HCF	LHBM16HEX#1ST	5/8"	1/2" - 1 1/8"	2 5/8"	3/4"	1 1/16"	1 1/2"	17 1/16"	140	15270	17330	9530	10840	13130	15200	8210	9490
	LHBM16HEX#2ST	5/8"	1 1/8" - 2"	3 5/8"	3/4"	1 1/16"	1 1/2"	17 1/16"	140	15270	17330	9530	10840	13130	15200	8210	9490
	LHBM16HEX#3ST	5/8"	2" - 2 13/16"	4 1/2"	3/4"	1 1/16"	1 1/2"	17 1/16"	140	15270	17330	9530	10840	13130	15200	8210	9490
	LHBM20HEX#1ST	3/4"	1/2" - 1 5/16"	3 1/8"	7/8"	1 5/16"	2"	1 13/16"	221	23040	26750	14410	16700	19510	25850	12190	16140
	LHBM20HEX#2ST	3/4"	1 5/16" - 2 3/8"	4 5/16"	7/8"	1 5/16"	2"	1 13/16"	221	23040	26750	14410	16700	19510	25850	12190	16140
	LHBM20HEX#3ST	3/4"	2 3/8" - 3 3/8"	5 1/2"	7/8"	1 5/16"	2"	1 13/16"	221	23040	26750	14410	16700	19510	25850	12190	16140

- ▶ Hollo-Bolts can be used on a variety of steel hollow sections and shapes. Limit States of the section, could occur at a lower figure and therefore its strength should be checked by a qualified Structural Engineer. Contact Lindapter for equivalent bearing area and diameter under cone.
- ▶ Refer to ESR-3330 and Lindapter's Special Inspection Document for details of connection design, installation and conditions of use.

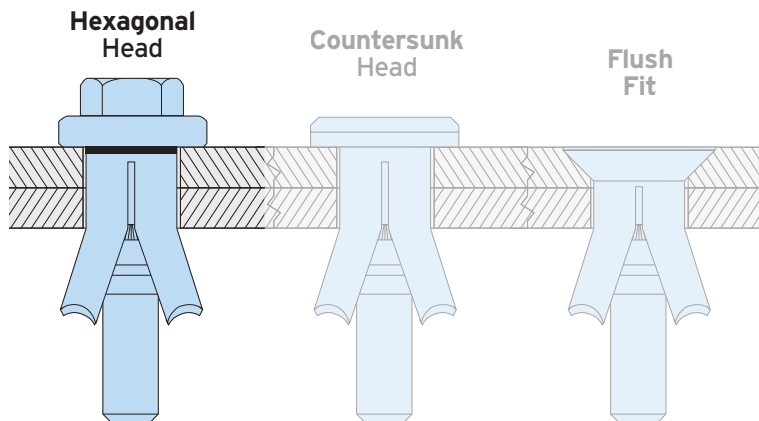

Hollo-Bolt™ Countersunk Head (data for applications requiring ICC approval)

ICC ES ESR-3330	Code Compliance	✓IBC	✓IRC
		✓CBC	✓CRC
		✓LABC	✓LARC

LRFD design strength and ASD allowable strength

LRFD and ASD strengths (taken from ESR-3330) are to be used when designing a connection per AISC 360, AISC 341, and ASCE/SEI 7 as referenced by the locally adopted building code.

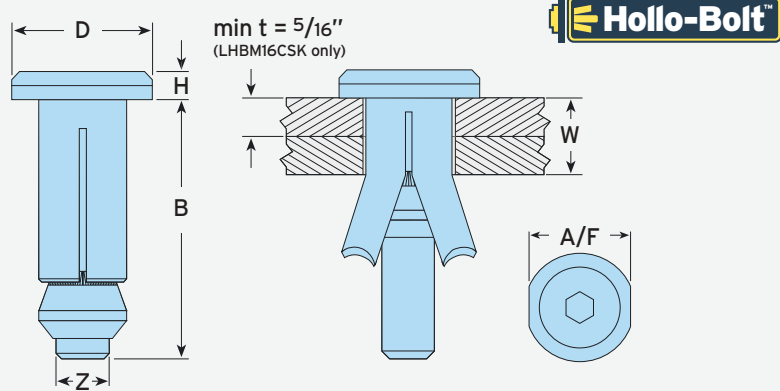

Data for Zinc + JS500 and Sheraplex

Material: Carbon steel.

Product Code	Bolt Ø Z	Clamping Range W	Length B	Height H	Drill Hole Diameter Ø	Collar		Tightening Torque ft lb	Allowable Loading							
						Ø D	A/F		Static and Wind Loads				Seismic Loads			
									Tensile lbs	Shear lbs	Tensile lbs	Shear lbs	LRFD Design Strength lbs	ASD Allowable Strength lbs	LRFD Design Strength lbs	ASD Allowable Strength lbs
LHBM08CSK#1	5/16"	1/4" - 7/8"	13/4"	3/16"	9/16"	7/8"	3/4"	17	3780	3220	2340	2000	3310	2680	2045	1670
LHBM08CSK#2	5/16"	7/8" - 15/8"	29/16"	3/16"	9/16"	7/8"	3/4"	17	3780	3220	2340	2000	3310	2680	2045	1670
LHBM08CSK#3	5/16"	15/8" - 23/8"	33/8"	3/16"	9/16"	7/8"	3/4"	17	3780	3220	2340	2000	3310	2680	2045	1670
LHBM10CSK#1	3/8"	5/16" - 7/8"	13/4"	1/4"	3/4"	11/8"	15/16"	33	6160	5490	3820	3420	5490	4570	3400	2830
LHBM10CSK#2	3/8"	7/8" - 15/8"	21/2"	1/4"	3/4"	11/8"	15/16"	33	6160	5490	3820	3420	5490	4570	3400	2830
LHBM10CSK#3	3/8"	15/8" - 23/8"	35/16"	1/4"	3/4"	11/8"	15/16"	33	6160	5490	3820	3420	5490	4570	3400	2830
LHBM12CSK#1	1/2"	5/16" - 1"	17/8"	1/4"	13/16"	11/4"	13/16"	59	8550	7490	5310	4680	7470	6250	4630	3890
LHBM12CSK#2	1/2"	1" - 113/16"	27/8"	1/4"	13/16"	11/4"	13/16"	59	8550	7490	5310	4680	7470	6250	4630	3890
LHBM12CSK#3	1/2"	113/16" - 23/4"	311/16"	1/4"	13/16"	11/4"	13/16"	59	8550	7490	5310	4680	7470	6250	4630	3890
HCF LHBM16CSK#1	5/8"	1/2" - 11/8"	27/16"	5/16"	11/16"	11/2"	17/16"	140	13900	11600	8640	7290	13300	9780	8270	6090
LHBM16CSK#2	5/8"	11/8" - 2"	35/8"	5/16"	11/16"	11/2"	17/16"	140	13900	11600	8640	7290	13300	9780	8270	6090
LHBM16CSK#3	5/8"	2" - 213/16"	47/16"	5/16"	11/16"	11/2"	17/16"	140	13900	11600	8640	7290	13300	9780	8270	6090

➤ Hollo-Bolts can be used on a variety of steel hollow sections and shapes. Limit States of the section, could occur at a lower figure and therefore its strength should be checked by a qualified Structural Engineer. Contact Lindapter for equivalent bearing area and diameter under cone.

➤ Refer to ESR-3330 and Lindapter's Special Inspection Document for details of connection design, installation and conditions of use.

HOW TO SPECIFY THE FINISH TO THE PRODUCT CODE

Example Product Code: **LHBM16CSK#1** → Choose your finish and add the finish code: Zinc Plated + JS500 **ZN**, Stainless Steel **ST**, Sheraplex **SP** → Final Product Code: **LHBM16CSK#1SP**

Hollo-Bolt™ Countersunk Head (data for applications requiring ICC approval)

Data for Stainless Steel

Product Code	Bolt Ø	Clamping Range	Length	Height	Drill Hole Diameter Ø	Collar		Tightening Torque	Allowable Loading								
						Ø	A/F		Static and Wind Loads				Seismic Loads				
									LRFD Design Strength		ASD Allowable Strength		LRFD Design Strength		ASD Allowable Strength		
						Tensile	Shear		Tensile	Shear	Tensile	Shear	Tensile	Shear			
Z	W	B	H	D	A/F	ft lb	lbs	lbs	lbs	lbs	lbs	lbs	lbs	lbs			
LHBM08CSK#1ST	5/16"	1/4" - 7/8"	13/4"	3/16"	9/16"	7/8"	3/4"	17	5980	6430	3730	4020	4790	4770	2990	2970	
LHBM08CSK#2ST	5/16"	7/8" - 15/8"	29/16"	3/16"	9/16"	7/8"	3/4"	17	5980	6430	3730	4020	4790	4770	2990	2970	
LHBM08CSK#3ST	5/16"	15/8" - 23/8"	33/8"	3/16"	9/16"	7/8"	3/4"	17	5980	6430	3730	4020	4790	4770	2990	2970	
LHBM10CSK#1ST	3/8"	5/16" - 7/8"	13/4"	1/4"	3/4"	1 1/8"	15/16"	33	9730	10930	6070	6830	8120	9220	5080	5760	
LHBM10CSK#2ST	3/8"	7/8" - 15/8"	21/2"	1/4"	3/4"	1 1/8"	15/16"	33	9730	10930	6070	6830	8120	9220	5080	5760	
LHBM10CSK#3ST	3/8"	15/8" - 23/8"	35/16"	1/4"	3/4"	1 1/8"	15/16"	33	9730	10930	6070	6830	8120	9220	5080	5760	
LHBM12CSK#1ST	1/2"	5/16" - 1"	17/8"	1/4"	13/16"	1 1/4"	13/16"	59	12190	13440	7620	8430	10250	12250	6410	7640	
LHBM12CSK#2ST	1/2"	1" - 1 13/16"	27/8"	1/4"	13/16"	1 1/4"	13/16"	59	12190	13440	7620	8430	10250	12250	6410	7640	
LHBM12CSK#3ST	1/2"	1 13/16" - 2 3/4"	31 1/16"	1/4"	13/16"	1 1/4"	13/16"	59	12190	13440	7620	8430	10250	12250	6410	7640	
HCF	LHBM16CSK#1ST	5/8"	1/2" - 1 1/8"	27/16"	5/16"	1 1/16"	1 1/2"	17 1/16"	140	15270	17330	9530	10840	13130	15200	8210	9490
	LHBM16CSK#2ST	5/8"	1 1/8" - 2"	35/8"	5/16"	1 1/16"	1 1/2"	17 1/16"	140	15270	17330	9530	10840	13130	15200	8210	9490
	LHBM16CSK#3ST	5/8"	2" - 2 13/16"	47/16"	5/16"	1 1/16"	1 1/2"	17 1/16"	140	15270	17330	9530	10840	13130	15200	8210	9490

- ▶ Hollo-Bolts can be used on a variety of steel hollow sections and shapes. Limit States of the section, could occur at a lower figure and therefore its strength should be checked by a qualified Structural Engineer. Contact Lindapter for equivalent bearing area and diameter under cone.
- ▶ Refer to ESR-3330 and Lindapter's Special Inspection Document for details of connection design, installation and conditions of use.

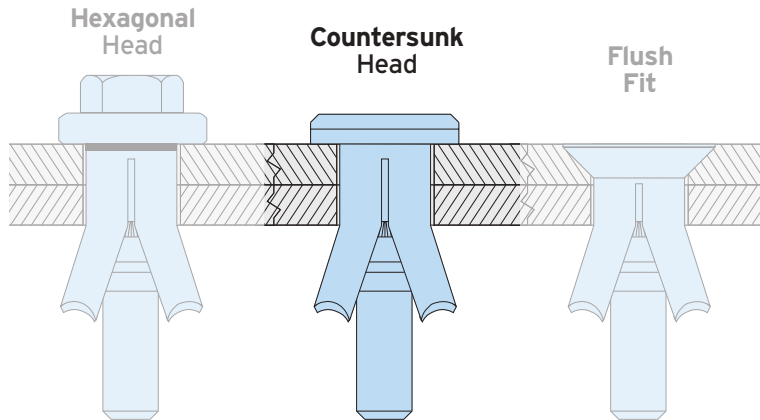

Hollo-Bolt™ Flush Fit Head (data for applications requiring ICC approval)

ICC ES ESR-3330	Code Compliance	✓IBC	✓IRC
		✓CBC	✓LARC
		✓CRC	✓LABC

LRFD design strength and ASD allowable strength

LRFD and ASD strengths (taken from ESR-3330) are to be used when designing a connection per AISC 360, AISC 341, and ASCE/SEI 7 as referenced by the locally adopted building code.

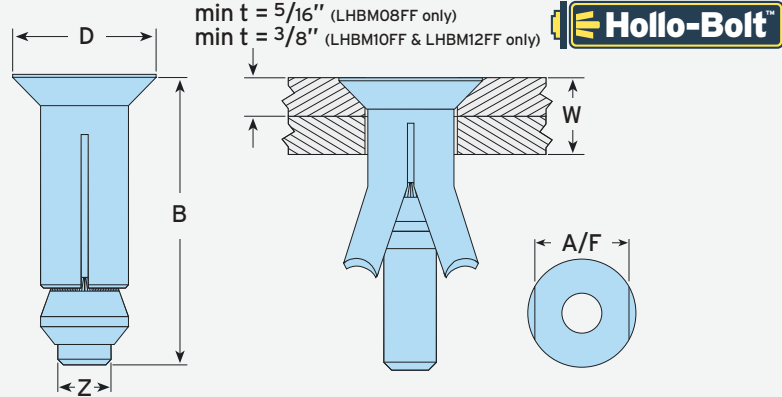

Data for Zinc + JS500 and Sheraplex

Material: Carbon steel.

Product Code	Countersunk Bolt Ø Z	Clamping Range W	Length B	Collar		Tightening Torque ft lb	Allowable Loading							
				Ø D	Installation Nut A/F		Static and Wind Loads				Seismic Loads			
							LRFD Design Strength		ASD Allowable Strength		LRFD Design Strength		ASD Allowable Strength	
Tensile lbs	Shear lbs	Tensile lbs	Shear lbs	Tensile lbs	Shear lbs	Tensile lbs	Shear lbs							
LHBM08FF#1	5/16"	3/8" - 11/16"	2"	15/16"	3/4"	17	3780	3220	2340	2000	3310	2680	2045	1670
LHBM08FF#2	5/16"	11/16" - 13/4"	2 3/4"	15/16"	3/4"	17	3780	3220	2340	2000	3310	2680	2045	1670
LHBM08FF#3	5/16"	1 3/4" - 2 1/2"	3 9/16"	15/16"	3/4"	17	3780	3220	2340	2000	3310	2680	2045	1670
LHBM10FF#1	3/8"	1/2" - 1 1/16"	2"	1 3/16"	15/16"	33	6160	5490	3820	3420	5490	4570	3400	2830
LHBM10FF#2	3/8"	1 1/16" - 1 3/4"	2 3/4"	1 3/16"	15/16"	33	6160	5490	3820	3420	5490	4570	3400	2830
LHBM10FF#3	3/8"	1 3/4" - 2 1/2"	3 9/16"	1 3/16"	15/16"	33	6160	5490	3820	3420	5490	4570	3400	2830
LHBM12FF#1	1/2"	1/2" - 1 3/16"	2 3/16"	1 5/16"	1 3/16"	59	8550	7490	5310	4680	7470	6250	4630	3890
LHBM12FF#2	1/2"	1 3/16" - 2"	3 1/8"	1 5/16"	1 3/16"	59	8550	7490	5310	4680	7470	6250	4630	3890
LHBM12FF#3	1/2"	2" - 2 7/8"	4"	1 5/16"	1 3/16"	59	8550	7490	5310	4680	7470	6250	4630	3890

- ▶ Hollo-Bolts can be used on a variety of steel hollow sections and shapes. Limit States of the section, could occur at a lower figure and therefore its strength should be checked by a qualified Structural Engineer. Contact Lindapter for equivalent bearing area and diameter under cone.
- ▶ Refer to ESR-3330 and Lindapter's Special Inspection Document for details of connection design, installation and conditions of use.
- ▶ For drilling hole preparation please refer to page 65.

HOW TO SPECIFY THE FINISH TO THE PRODUCT CODE

Example Product Code: **LHBM08FF#2** → Choose your finish and add the finish code → Final Product Code: **LHBM08FF#2ZN**

Available finishes: Zinc Plated + JS500 (ZN), Stainless Steel (ST), Sheraplex (SP)

Hollo-Bolt™ Flush Fit Head

(data for applications requiring ICC approval)

Data for Stainless Steel

Product Code	Countersunk Bolt Ø	Clamping Range	Length	Collar		Tightening Torque	Allowable Loading							
				Ø	Installation Nut		Static and Wind Loads				Seismic Loads			
							Tensile	Shear	Tensile	Shear	Tensile	Shear	Tensile	Shear
Z	W	B	D	A/F	ft lb	lbs	lbs	lbs	lbs	lbs	lbs	lbs	lbs	
LHBM08FF#1ST	5/16"	3/8" - 1 1/16"	2"	15/16"	3/4"	17	5980	6430	3730	4020	4790	4770	2990	2970
LHBM08FF#2ST	5/16"	1 1/16" - 1 3/4"	2 3/4"	15/16"	3/4"	17	5980	6430	3730	4020	4790	4770	2990	2970
LHBM08FF#3ST	5/16"	1 3/4" - 2 1/2"	3 9/16"	15/16"	3/4"	17	5980	6430	3730	4020	4790	4770	2990	2970
LHBM10FF#1ST	3/8"	1/2" - 1 1/16"	2"	1 3/16"	15/16"	33	9730	10930	6070	6830	8120	9220	5080	5760
LHBM10FF#2ST	3/8"	1 1/16" - 1 3/4"	2 3/4"	1 3/16"	15/16"	33	9730	10930	6070	6830	8120	9220	5080	5760
LHBM10FF#3ST	3/8"	1 3/4" - 2 1/2"	3 9/16"	1 3/16"	15/16"	33	9730	10930	6070	6830	8120	9220	5080	5760
LHBM12FF#1ST	1/2"	1/2" - 1 3/16"	2 3/16"	1 5/16"	1 3/16"	59	12190	13440	7620	8430	10250	12250	6410	7640
LHBM12FF#2ST	1/2"	1 3/16" - 2"	3 1/8"	1 5/16"	1 3/16"	59	12190	13440	7620	8430	10250	12250	6410	7640
LHBM12FF#3ST	1/2"	2" - 2 7/8"	4"	1 5/16"	1 3/16"	59	12190	13440	7620	8430	10250	12250	6410	7640

- ▶ Hollo-Bolts can be used on a variety of steel hollow sections and shapes. Limit States of the section, could occur at a lower figure and therefore its strength should be checked by a qualified Structural Engineer. Contact Lindapter for equivalent bearing area and diameter under cone.
- ▶ Refer to ESR-3330 and Lindapter's Special Inspection Document for details of connection design, installation and conditions of use.
- ▶ For drilling hole preparation please refer to page 65.

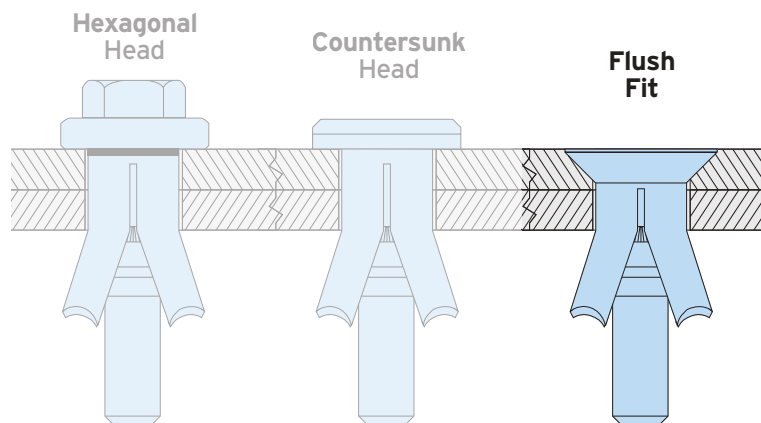

Hollo-Bolt Hexagonal and Countersunk - Drilling and Installation

To comply with ICC-ES ESR-3330 Section 4.2 ensure that the holes are drilled into both the fixture and the section according to the drilling guidelines below. Please note that the holes are slightly larger than standard bolt drill diameters to accommodate the sleeve and cone.

Preparation for installing Hollo-Bolt Hexagonal and Countersunk

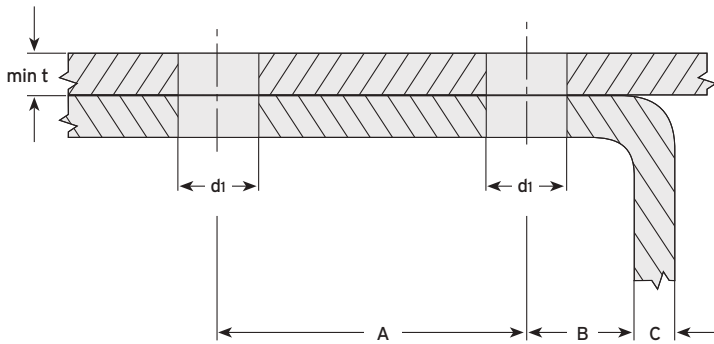

Product Code		Outer Ply min t	Drill Diameter Ø d1	Hole Distances*		Edge Distances* B + C
Hexagonal	Countersunk			min A	min B	
LHBM08HEX	LHBM08CSK	-	9/16"	13/8"	1/2"	≥ 11/16"
LHBM10HEX	LHBM10CSK	-	3/4"	19/16"	9/16"	≥ 7/8"
LHBM12HEX	LHBM12CSK	-	13/16"	2"	11/16"	≥ 1"
LHBM16HEX	LHBM16CSK	5/16"	11/16"	2 3/16"	13/16"	≥ 1 5/16"
LHBM20HEX	-	5/16"	1 5/16"	2 3/4"	1"	≥ 1 5/16"

* Ensure holes do not cut through outer radius.

► Sizes 5/8" and 3/4" require outer ply thickness (min t) to be at least 5/16".

Tool sizes for installing Hollo-Bolt Hexagonal

Hollo-Bolt Hexagonal			
Product Code	Wrench	Socket	Tightening Torque ft lb
	mm	mm	
LHBM08HEX	19 (3/4")	13 (1/2")	17
LHBM10HEX	24 (15/16")	17 (11/16")	33
LHBM12HEX	30 (13/16")	19 (3/4")	59
LHBM16HEX	36 (17/16")	24 (15/16")	140
LHBM20HEX	46 (13/16")	30 (13/16")	221

* Note: Metric, nearest equivalent shown in brackets.

Tool sizes for installing Hollo-Bolt Countersunk

Hollo-Bolt Countersunk			
Product Code	Wrench	Allen Wrench	Tightening Torque ft lb
	mm	mm	
LHBM08CSK	19 (3/4")	5 (3/16")	17
LHBM10CSK	24 (15/16")	6 (7/32")	33
LHBM12CSK	30 (13/16")	8 (5/16")	59
LHBM16CSK	36 (17/16")	10 (3/8")	140

* Note: Metric, nearest equivalent shown in brackets.

How to install...

▶ Watch the Hollo-Bolt installation video at www.Lindapter.com

- 1) Align pre-drilled fixture and section then insert the Hollo-Bolt^a.
- 2) Grip Hollo-Bolt collar with an open ended wrench.
- 3) Using a calibrated torque wrench, tighten the central bolt to the recommended torque^b.

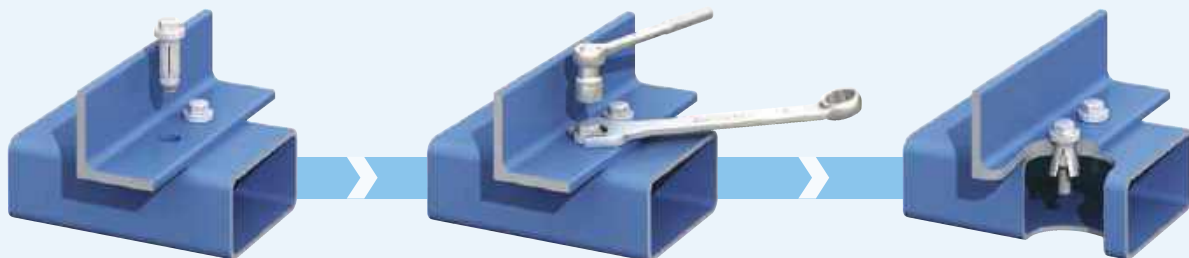

Notes:

- a) Before tightening, ensure that the materials that are to be connected together are touching.
- b) Rotate the torque wrench only. See table above for tightening torque.
- c) Power tools, such as an impact wrench, may be used to speed up the tightening of the Hollo-Bolt. However, when using power tools, always complete the tightening process with a calibrated torque wrench to ensure the correct torque is applied to the Hollo-Bolt.

Hollo-Bolt Flush Fit - Drilling and Installation

To comply with ICC-ES ESR-3330 Section 4.2 ensure that the holes are drilled into both the fixture and the section according to the drilling guidelines below. Please note that the holes are slightly larger than standard bolt drill diameters to accommodate the sleeve and cone.

Preparation for installing Hollo-Bolt Flush Fit

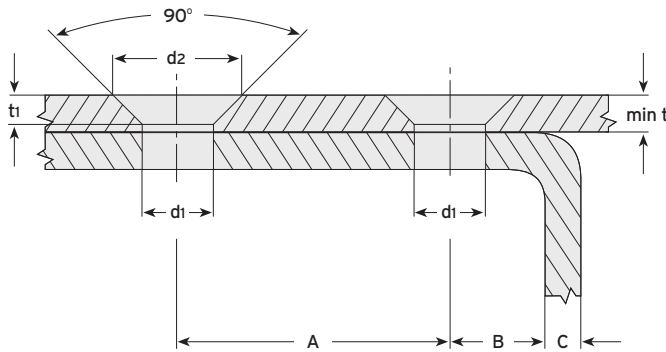

Product Code	Outer Ply min t	Drill Diameter Ø d1	Countersunk		Hole Distances*		Edge Distances* B + C
			d2	t1	min A	min B	
LHBM08FF	5/16"	9/16"	1 1/16"	1/4"	1 3/8"	1/2"	≥ 1 1/16"
LHBM10FF	3/8"	3/4"	1 1/4"	1/4"	1 9/16"	9/16"	≥ 7/8"
LHBM12FF	3/8"	13/16"	1 3/8"	5/16"	2"	1 1/16"	≥ 1"

* Ensure holes do not cut through outer radius.

Tool sizes for installing Hollo-Bolt Flush Fit

Hollo-Bolt Flush Fit			
Product Code	Wrench mm	Allen Wrench mm	Tightening Torque ft lb
LHBM08FF	19 (3/4")	5 (3/16")	17
LHBM10FF	24 (15/16")	6 (7/32")	33
LHBM12FF	30 (1 3/16")	8 (5/16")	59

* Note: Metric, nearest equivalent shown in brackets.

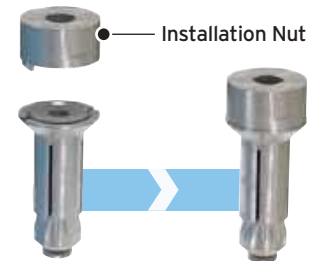

How to install...

▶ Watch the Hollo-Bolt installation video at www.Lindapter.com

- 1) Align pre-drilled fixture and section then insert Hollo-Bolt[®].
- 2) Apply the installation nut and grip with an open ended wrench.
- 3) Using a calibrated torque wrench, tighten the central countersunk bolt to the recommended torque^{b)}.



Notes:

- a) Before tightening, ensure that the materials that are to be connected together are touching.
- b) Rotate the torque wrench only (the installation nut is for restraining only). See table above for tightening torque.
- c) Power tools, such as an impact wrench, may be used to speed up the tightening of the Hollo-Bolt. However, when using power tools, always complete the tightening process with a calibrated torque wrench to ensure the correct torque is applied to the Hollo-Bolt.

Typical Applications for Hollo-Bolt

Popular connection assemblies are shown below. They represent a fraction of the possibilities as Lindapter's clamps are used all over the world to connect almost every type of steel section. Please contact Lindapter to discuss your connection requirement.

GIRDER CLAMPS

LIFTING POINTS

HOLLO-BOLT

FLOOR CONNECTIONS

PIPE SUPPORTS

FAQS & CASE STUDIES

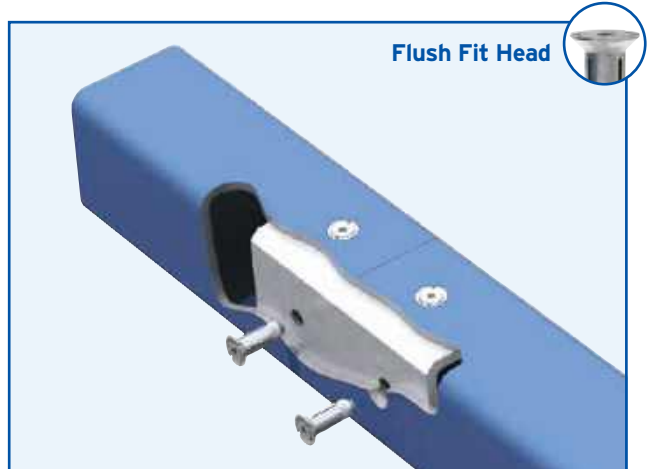
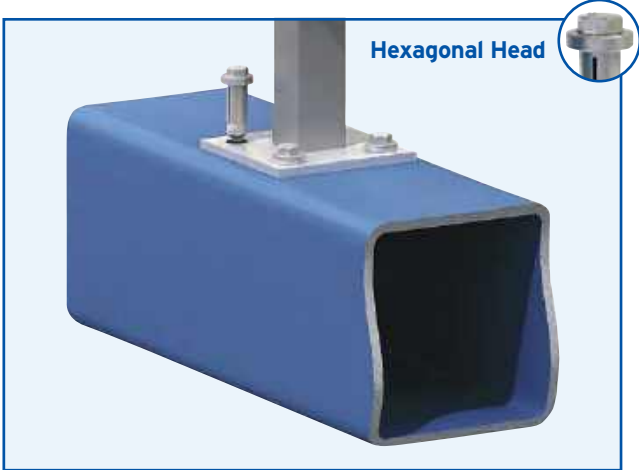

Typical Applications for Hollo-Bolt

Examples of popular connection assemblies are continued below. Please contact Lindapter to discuss your connection requirement.

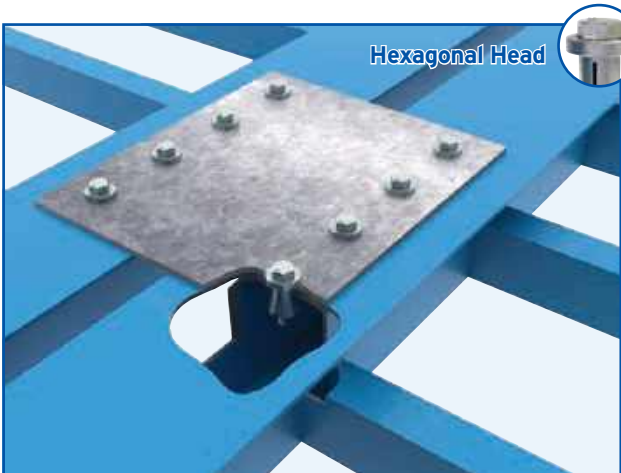
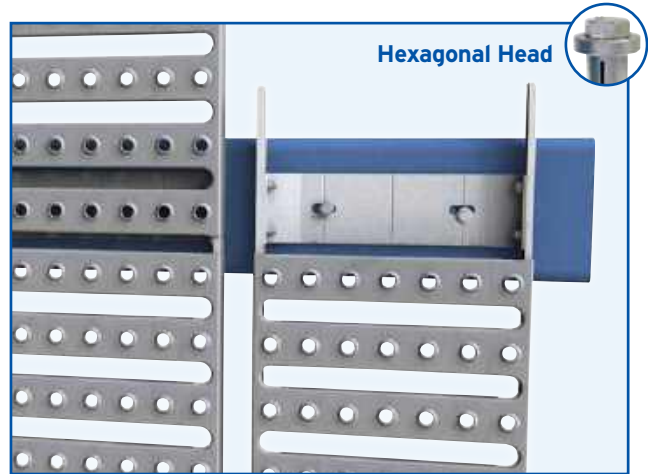
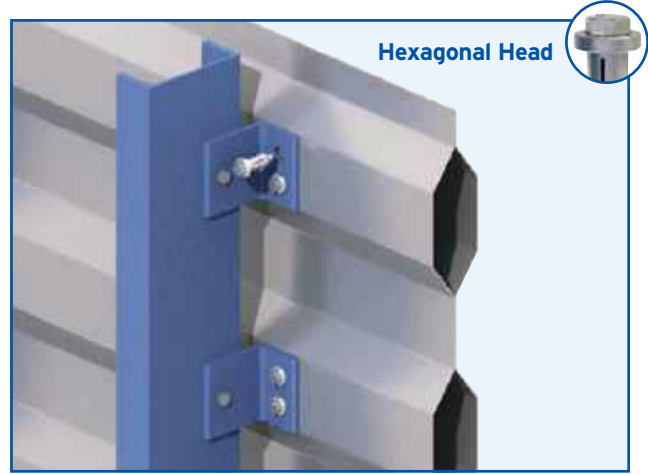

GIRDER CLAMPS

LIFTING POINTS

HOLLO-BOLT

FLOOR CONNECTIONS

PIPE SUPPORTS

FAOS & CASE STUDIES

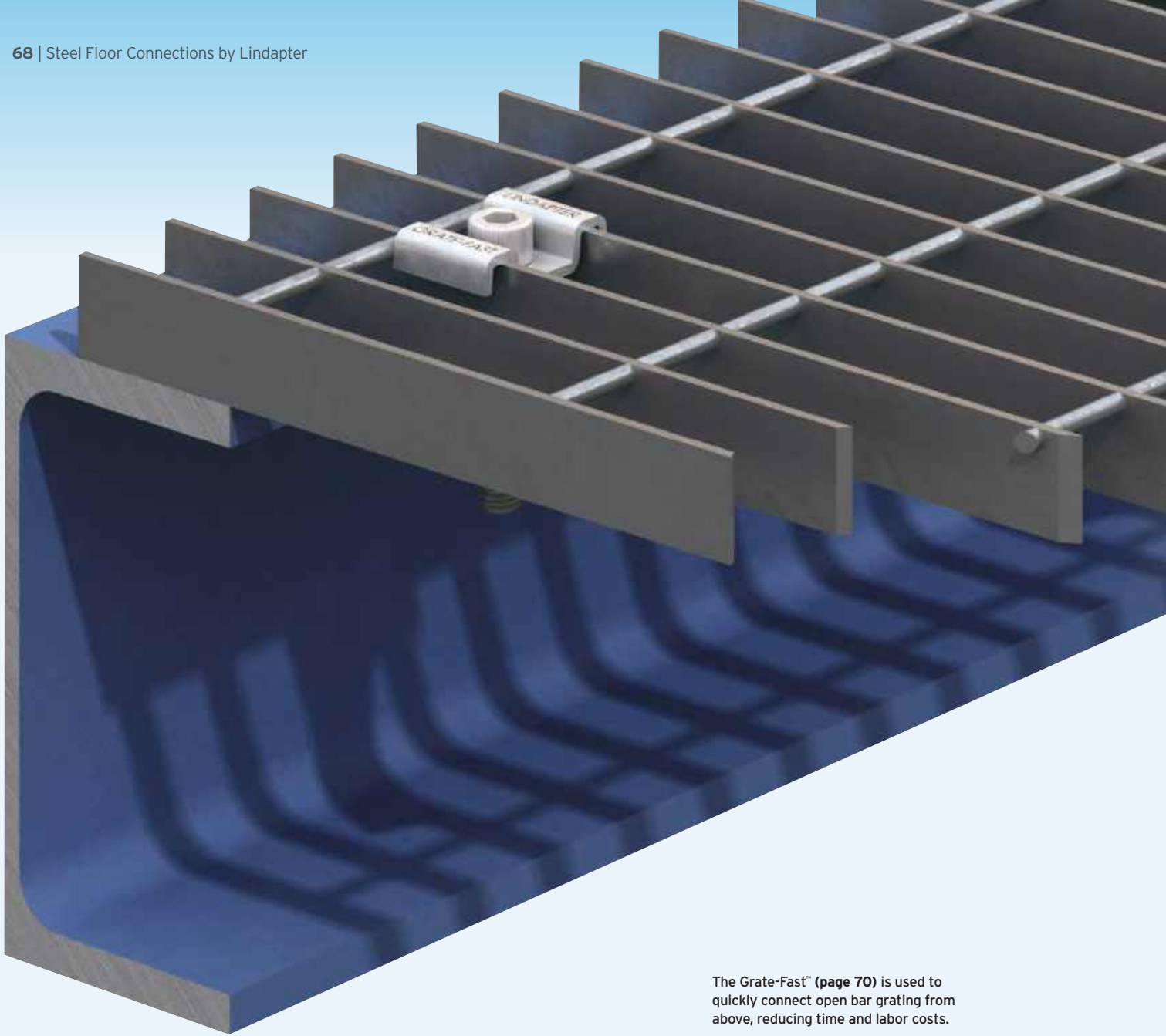

The Grate-Fast™ (page 70) is used to quickly connect open bar grating from above, reducing time and labor costs.

Steel Floor Connections

A range of innovative connections for securing steel flooring to supporting steel without drilling or welding in the field. Access to the underside is not required, eliminating the need for costly scaffolding or elevated floors.

**Type FF
FloorFast™**
page 69

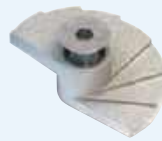

**Type GF
Grate-Fast™**
page 70



**Type
1055**
page 71



Type FF - FloorFast™

Securing checker plate flooring to supporting steel can be carried out quickly and safely from above, often by one person, significantly reducing costs. The stepped clamping face locks under the steel to provide a secure connection.



Unique stepped clamping face

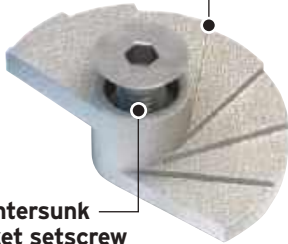

Countersunk socket setscrew

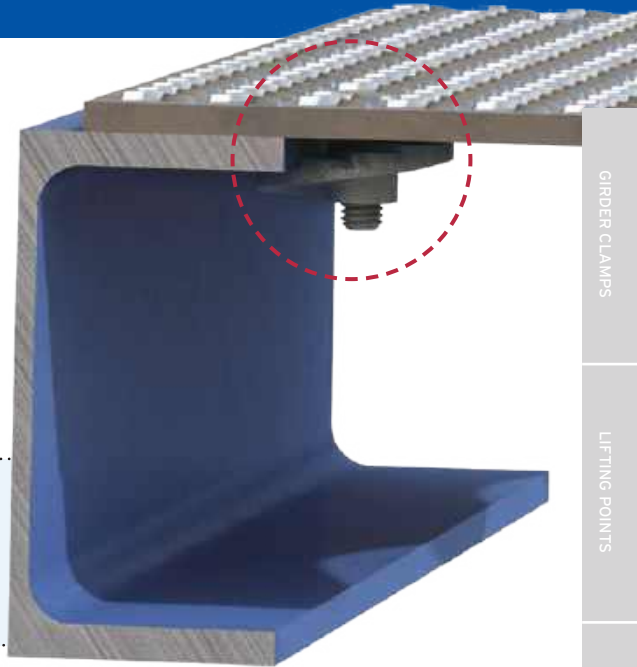
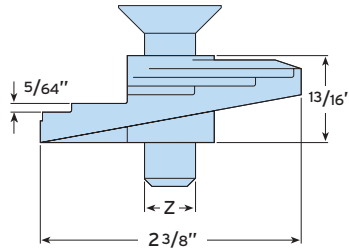

GIRDER CLAMPS

LIFTING POINTS

HOLLO-BOLT

FLOOR CONNECTIONS

PIPE SUPPORTS

FAOS & CASE STUDIES

- Superior clamping force from the cast body.
- Lloyd's Register Type Approval for resistance to shock and vibration.
- Zero protrusion above the surface of the floor plate.
- Easy to remove for maintenance access.
- Available in malleable iron or stainless steel grade 316.

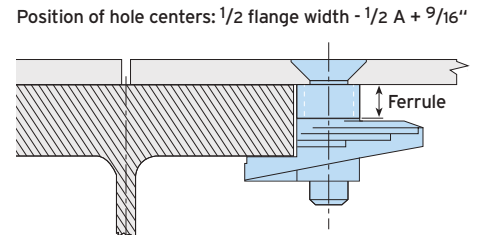
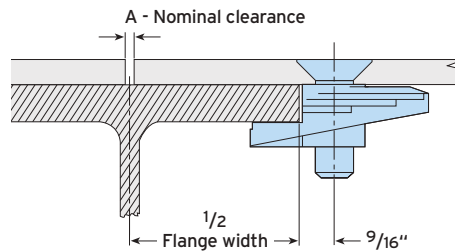
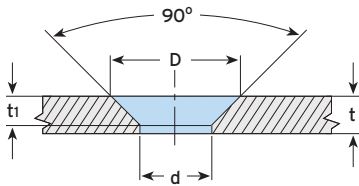

Material: Malleable iron, zinc plated or hot dip galvanized. Also available in stainless steel grade 316.

Product Code	Bolt ¹⁾ Z	Floorplate Thickness t	Floorfast	Flange Thickness			Dimensions						
				Floorfast with Ferrule ²⁾			Hole Ø d	Countersunk Ø for Bolt		Countersunk Depth for Bolt		Tight. Torque ft lb	Hexagon Key mm
				10mm (3/8")	20mm (13/16")	30mm (13/16")		BZP D	HDG D	BZP t1	HDG t1		
LFF031	M8 (5/16")	3/16" - 1/2"	1/8" - 5/8"	1/2" - 1"	7/8" - 13/8"	15/16" - 13/16"	3/8"	11/16"	-	3/16"	-	8	5 (3/16")
LFF037	M10 (3/8")	3/16" - 1/2"	1/8" - 5/8"	1/2" - 1"	7/8" - 13/8"	15/16" - 13/16"	7/16"	13/16"	3/4"	3/16"	3/16"	16	6 (7/32")
LFF050	M12 (1/2")	1/4" - 1/2"	1/8" - 5/8"	1/2" - 1"	7/8" - 13/8"	15/16" - 13/16"	9/16"	1"	15/16"	1/4"	3/16"	16	8 (5/16")

1) Hot dip galvanized M10 and M12 versions are supplied with a slotted countersunk screw. 2) To order FloorFast with a ferrule, simply add ferrule size to product code (eg. LFF050 with 10mm (3/8") ferrule).

➤ Safe Working Loads (LFF031/LFF037/LFF050): Tensile = 450lbs/bolt (4:1 FoS) Slip = 112lbs/4 bolts (4:1 FoS) ➤ Designed for pedestrian walkways only.

How to install...

- 1) Assemble bolt and FloorFast through the checker plate.
- 2) Align castings with the straight edge parallel to the edge of the plate and hand tighten.
- 3) Lay the floorplate into position.
- 4) Using a hexagon key release countersunk screw one full turn.
- 5) Tighten down the countersunk socket screw.



▶ Watch the installation at www.Lindapter.com

Removal: Using a hexagon key, give the FloorFast one full anti-clockwise turn to release the connection from the flange.

Type GF - Grate-Fast™

A high strength floor connection for rectangular open bar grating, providing superior clamping force due to a malleable iron cast body. Lloyd's Register Type Approval for resistance to shock and vibration.



LGFO37

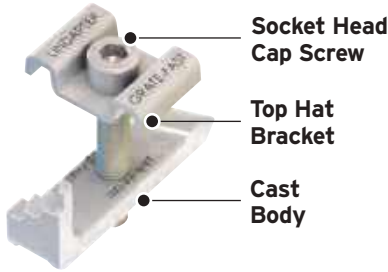

LGFO25-11W

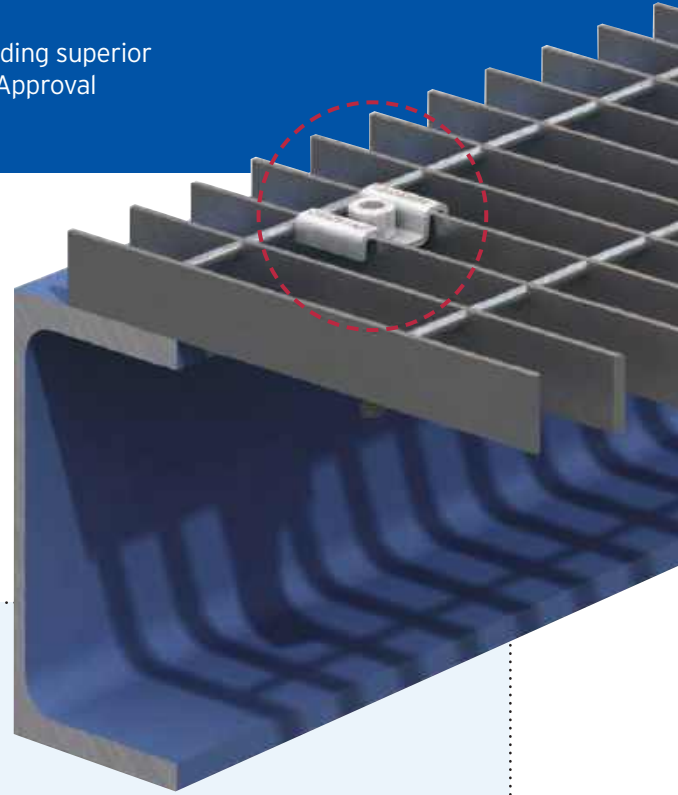

- Easy to remove for maintenance access.
- **LGFO25-11W** for 11-W or 11-P series of close mesh bar grating.
- **LGFO31** for GRP grating with stainless steel top hat bracket, Sheraplex coated body and socket head screw.
- **LGFO37** is hot dip galvanized for use with 13/16" width floor grating bars only.

LGFO31

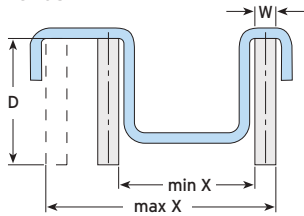

Top Hat Material:
Stainless steel (LGFO31 only). Mild Steel, hot dip galvanized (LGFO25-11W and LGFO37 only).

Body Material:
Malleable iron, Sheraplex (LGFO31 only). Malleable iron, hot dip galvanized (LGFO25-11W and LGFO37 only).

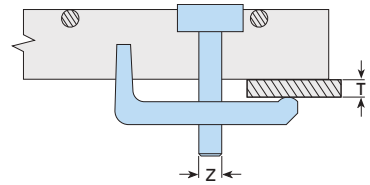

LGFO37 / LGFO25-11W

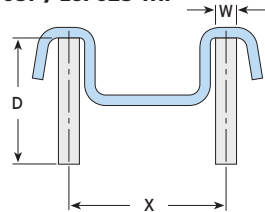

Product Code	Bolt Z	Flange T	Grating Bar Depth D	Grating Bar Width W	Bar Distance X	Tightening Torque ft lb	Hex. Key / Socket mm
LGFO25-11W	M6 (1/4")	1/4" - 3/4"	1" - 2"	1/8" - 3/16"	11/16"	3	5 (3/16")
LGFO31¹⁾	M8 (5/16")	1/8" - 3/4"	7/8" - 1 1/2"	3/16" - 3/8"	3/4" - 17/8"	4	6 (7/32")
LGFO37¹⁾	M10 (3/8")	1/8" - 3/4"	3/4" - 1 9/16"	1/8" - 1/4"	13/16"	8	8 (5/16")

1) Supplied with socket head cap screw.

- **Safe Working Loads (LGFO31/LGFO37):** Tensile = 360lbs/bolt (4:1 FoS) Slip = 112lbs/4 bolts (4:1 FoS)
- **Safe Working Loads (LGFO25-11W):** Slip = 24lbs/4 bolts (4:1 FoS) ➤ **Designed for pedestrian walkways only.**

How to install...

- 1) Position pre-assembled Grate-Fast with the body between the grating bars and the nose pointing towards the steel. The arrows on the top hat bracket should also be point towards the supporting steel and the bracket itself resting on the bearing bars.
- 2) Slide the Grate-Fast towards the steel until the nose fits under the beam flange. Where necessary adjust the body / screw to the approximate flange thickness / grating depth.
- 3) Tighten the screw. The Grate-Fast body will automatically rotate until it locks under the bearing bar, with the nose under the flange. Tighten to the recommended torque.

▶ Watch the installation video at www.Lindapter.com

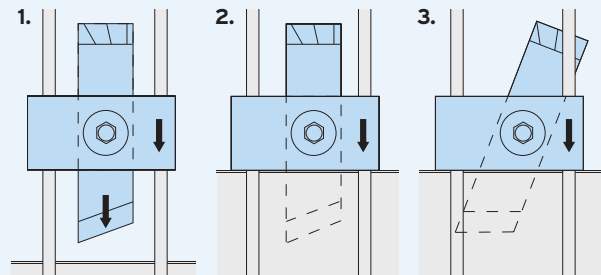

GIRDER CLAMPS

LIFTING POINTS

HOLLO-BOLT

FLOOR CONNECTIONS

PIPE SUPPORTS

FAQS & CASE STUDIES

Type 1055

This unique solution enables solid plate flooring to be fitted to open-mesh or open-grid flooring using simple hand tools.

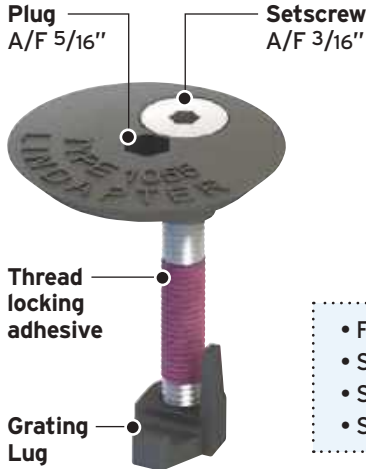
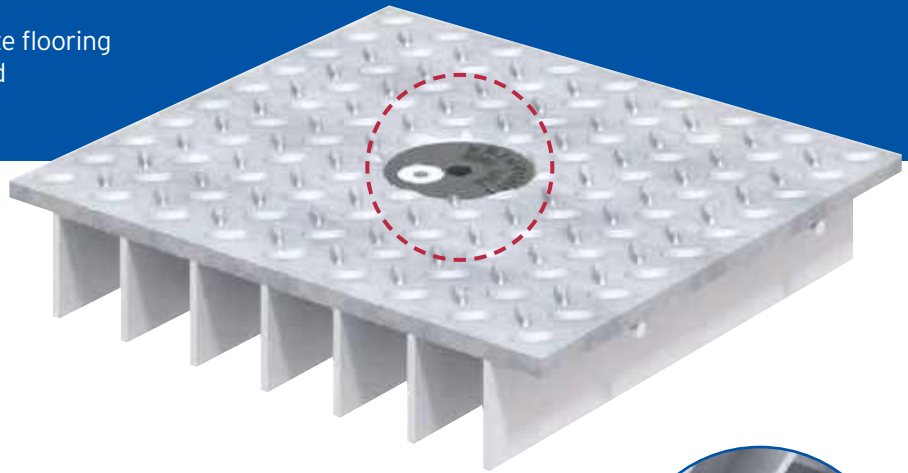

- Fast installation from above, no expensive scaffolding needed.
- Stainless steel for high corrosion resistance.
- Superior clamping force from high quality castings.
- Safely retrofit without welding.

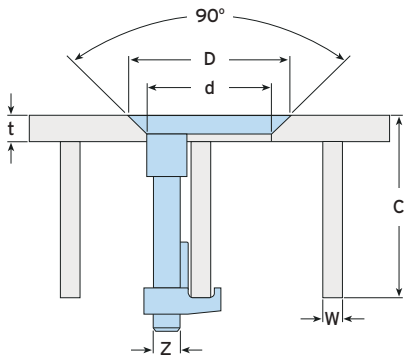
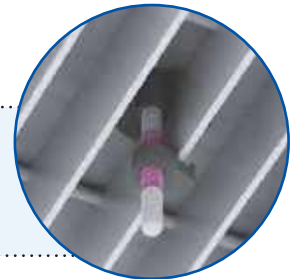

Material: Cast stainless steel, self colour.

Product Code	A4-70 Bolt	Floorplate Thickness	Clamping Range	Grating Bar Width	Hole Ø	Csk Ø	Setscrew	
							Tight. Torque	Hexagon Key
	Z	t	C	W	d	D	ft lb	mm
LFG1055	M8 (5/16")	min 1/4"	1 3/8" - 2 3/16"	1/8" - 5/16"	1 5/8"	2"	8	5 (3/16")

- Safe Working Loads (LFG1055): Tensile = 225lbs/bolt (4:1 FoS) Slip = 34lbs/4 bolts (4:1 FoS)
- Designed for pedestrian walkways only.

How to install...

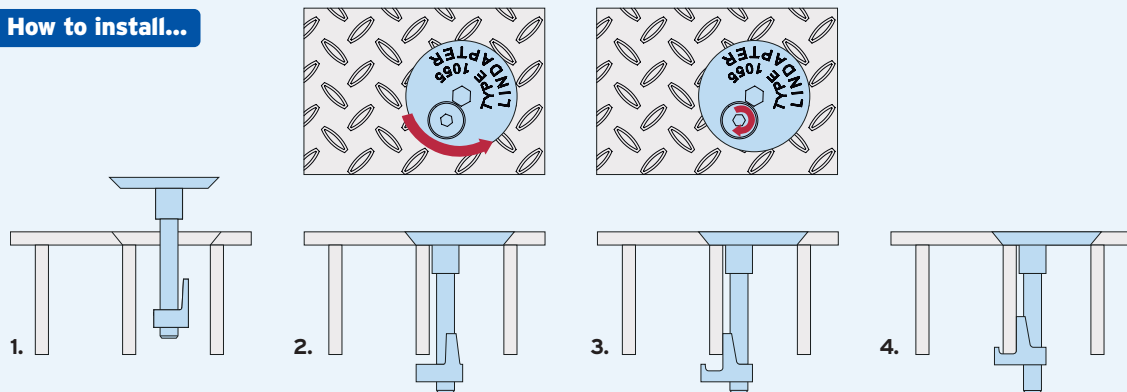

- 1) Insert the pre-assembled Type 1055 into the countersunk hole between the grating bars.
- 2) Use an 5/16" hexagon key to rotate the plug anti-clockwise until the underside of the plug locates against the grating bar.
- 3) Use a 3/16" hexagon key to rotate the countersunk setscrew clockwise until the grating lug makes contact with the grating bar.
- 4) Tighten the setscrew to 8ft lb; the grating lug will be drawn up the screw and will activate the thread locking adhesive.

▶ Watch the installation video at www.Lindapter.com

GIRDER CLAMPS

LIFTING POINTS

HOLLO-BOLT

FLOOR CONNECTIONS

PIPE SUPPORTS

FAQS & CASE STUDIES



The Type F3 has a large clamping range to suit various flange thicknesses (see page 76).

Pipe / Conduit Supports

Easy-to-install connections for suspending building services from structural or secondary beams. Typical applications include supporting HVAC equipment, pipe work, fire protection and sprinkler systems. Adjustable to allow a fast, precise alignment of building services.



Type FLS
page 73



Type F3
page 76



Type FL
page 74



Type HW/HC
page 77



Type LC
page 75



Type TC
page 77



Type SW
page 75

Type FLS

A versatile flange clamp with a swivel unit for inclined applications. Supplied with a high tensile setscrew for a secure grip on both parallel and tapered flanges.

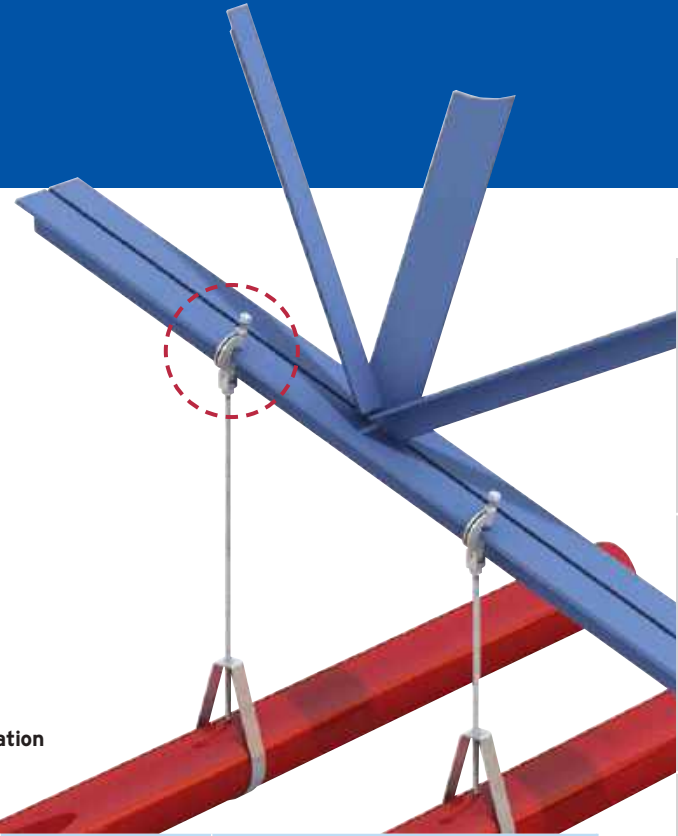
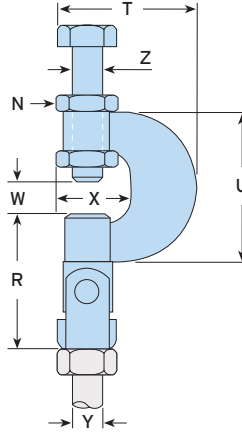
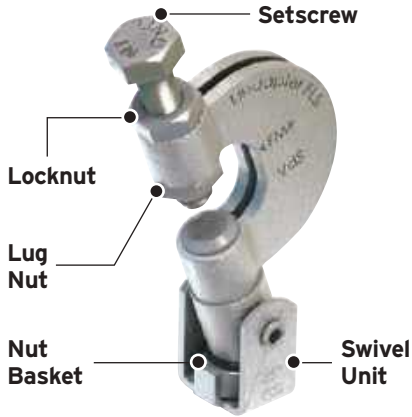

NEW: Independently fire tested in accordance with ASTM E-119 for a duration of 120 minutes. For fire-resistance load limits please contact Lindapter.

Material: High grade alloy steel, zinc plated.

Product Code	Rod Y	Safe Working Load (FOS 4:1)		Clamping Range W	Setscrew* Z	Tightening Torque		Dimensions				
		Tensile ≤ 25° lbs	Tensile 25° to 45° lbs			Setscrew Z ft lb	Locknut N ft lb	R	T	U	X	Width
LFLS037	3/8" UNC	550	330	1/8" - 11/16"	M10 (3/8")	13	13	2 3/16"	2 1/8"	2 1/4"	1 1/16"	1 1/8"

* Metric setscrew supplied.

Independently Approved Applications

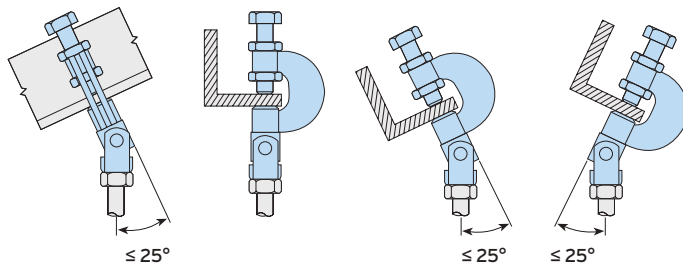

General Applications (Parallel Flanges only)

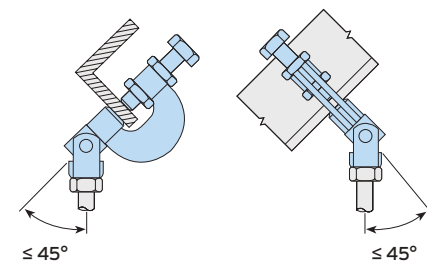

How to install...

- 1) Locate the FLS onto the flange.
- 2) Ensuring the lug nut (M) locates into the main body, tighten down the setscrew (Z) and locknut (N).
- 3) Install the 3/8" UNC threaded rod by screwing into the nut located in the nut basket (S). Ensure full thread capture.
- 4) Secure assembly in nut basket (S) from beneath using a nut (not supplied).

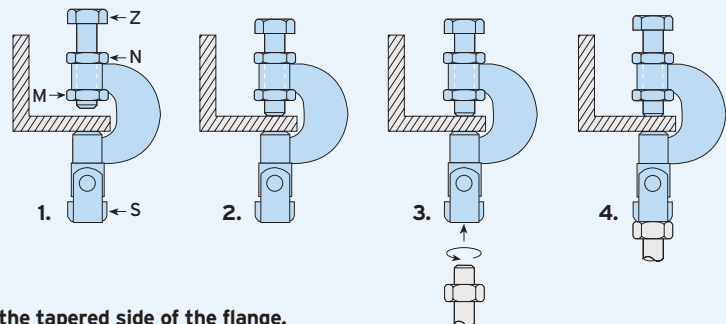

➤ Ensure that the cup point setscrew always grips on the tapered side of the flange.

Type FL

FM and VdS approved flange clamp for use with parallel or tapered flange beams, supplied with the rear hole drilled or tapped.

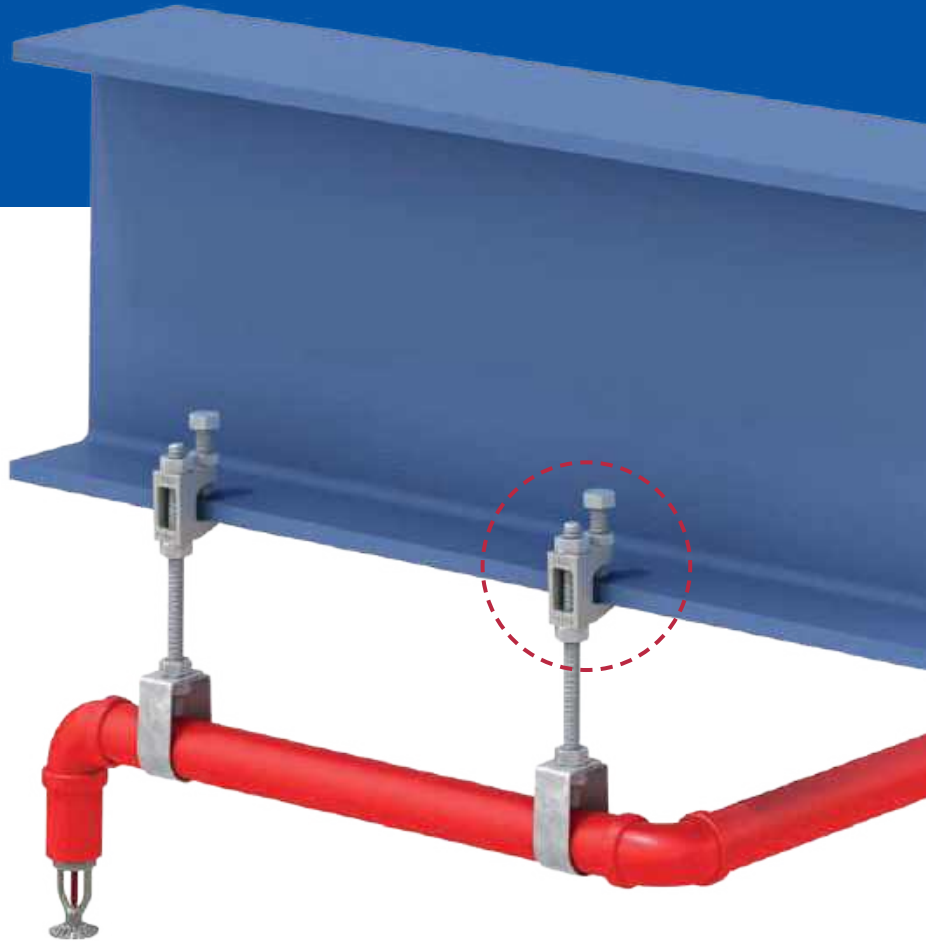
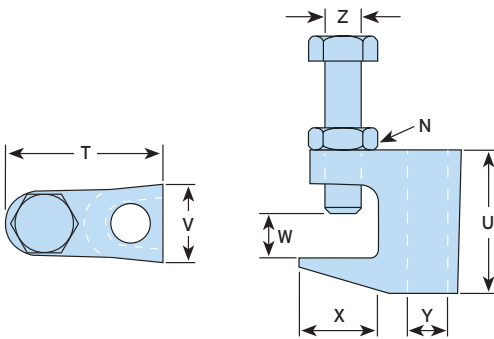
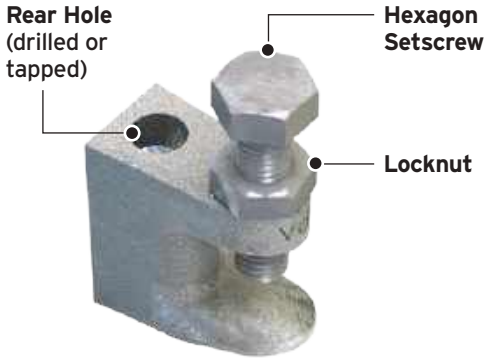

NEW: Independently fire tested in accordance with ASTM E-119 for a duration of 120 minutes. For fire-resistance load limits please contact Lindapter.

Material: Malleable iron, zinc plated.

Product Code				Safe Working Load (FOS 4:1) Tensile lbs	Clamping Range W	Setscrew ¹⁾ Z	Tightening Torque		Dimensions			
Drilled Hole	Tapped Hole	Drilled Hole Ø Y	Tapped Thread Y				Setscrew Z ft lb	Locknut N ft lb	T	U	X	Width V
LFL037C*	LFL037T	7/16"	3/8" UNC	540	1/8" - 25/32"	M10 (3/8")	6	16	1 3/4"	1 9/16"	7/8"	7/8"
LFL050C	LFL050T	1/2"	1/2" UNC	700	1/8" - 15/16"	M10 (3/8")	6	16	2"	1 13/16"	1 1/8"	1"

* Also available in stainless steel.
1) Metric setscrew supplied.

▶ The Type FL can be used with Type SW (page 75) when connecting to inclined sections.

How to install...

- Slide the Type FL onto the beam flange and tighten setscrew to the recommended torque. As a guide, tighten the setscrew finger tight and then apply an additional quarter turn (90°) with a 1 1/16" wrench.
 - Tighten the locknut (N) to the recommended torque.
- ▶ On tapered flanges, the cup point setscrew has to grip on the inside of the flange.**

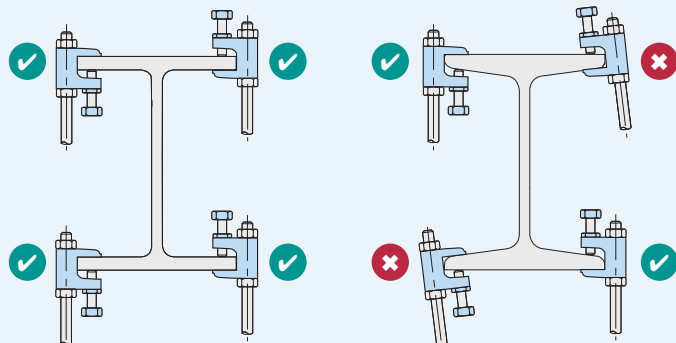

Type LC

A flange clamp with tapped holes to accept threaded rod or cable clips. Supplied with a high tensile cup point setscrew for parallel or tapered flanges.

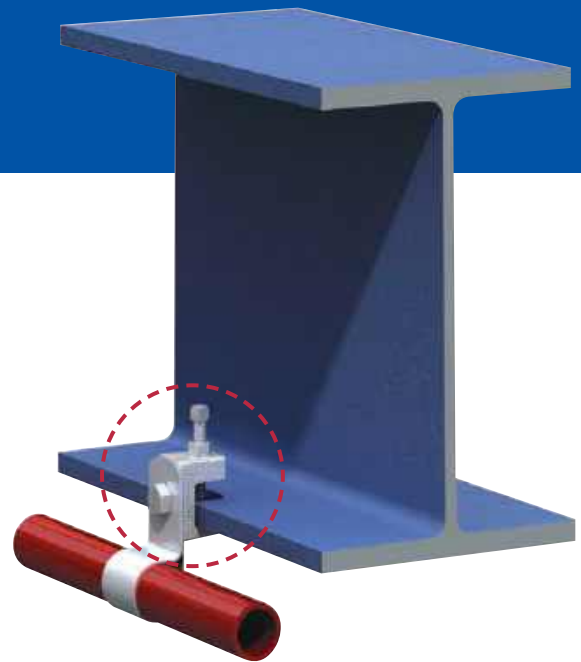
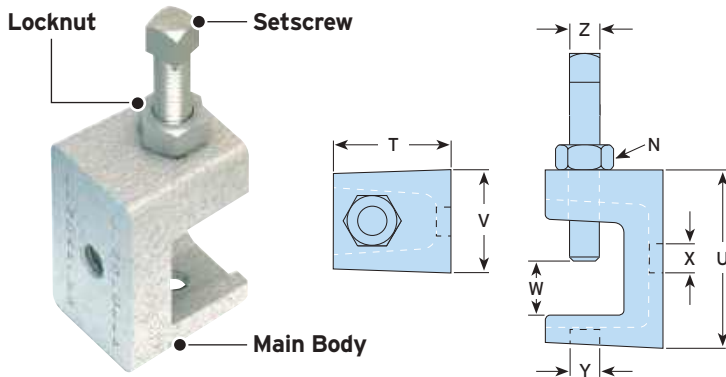

Material: Malleable iron, zinc plated.

Product Code	Tapped Thread		Safe Working Load (FOS 4:1)			Setscrew* Z	Tightening Torque		Dimensions		
	X	Y	Tensile in Position X lbs	Tensile in Position Y lbs	Clamping Range W		Setscrew Z ft lb	Locknut N ft lb	T	U	Width V
LLC025	1/4" UNC	1/4" UNC	40	135	1/8" - 11/16"	M6 (1/4")	3	3	1"	17/16"	7/8"

* Metric setscrew supplied.

➔ Installation is the same as Type FL (page 74).

Type SW

A swivel unit for applications on inclined beams complete with a M10 (3/8" x 3 9/16") Grd. 5 setscrew and nut. Can be supplied with Type FL.

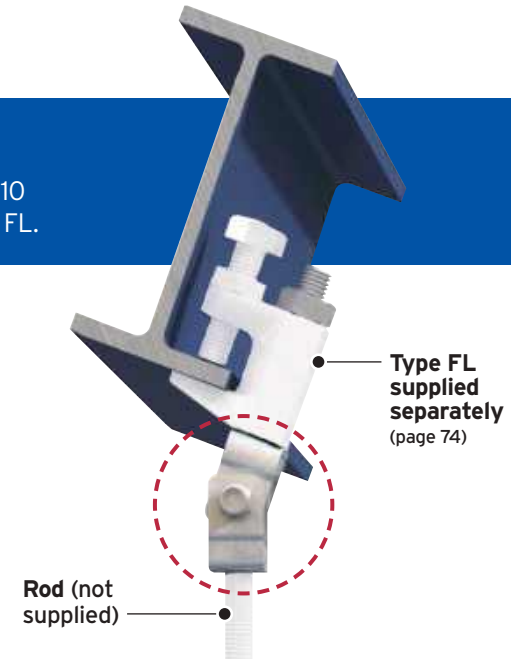
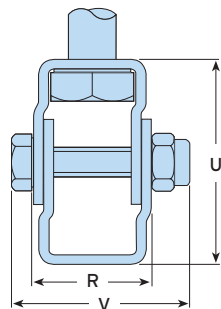

Material: High grade alloy steel, zinc plated.

Product Code	Rod*	Safe Working Load (FOS 4:1)			Rotation	Tightening Torque ft lb	Dimensions		
		Tensile lbs	Maximum Inclination	U			R	Width with Bolt V	
LSW037	M10 or 3/8"	540	18°	360°	8	13/4"	1"	13/8"	

* Secure threaded rod (either M10 or 3/8") to the Type SW using a standard nut.

Type F3

An FM approved, high strength flange clamp with a large clamping range.

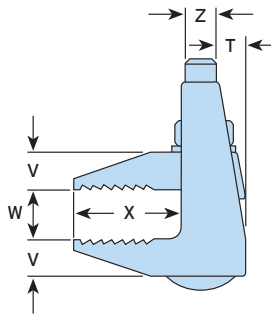
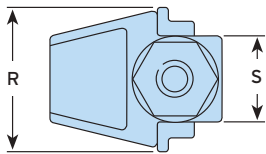
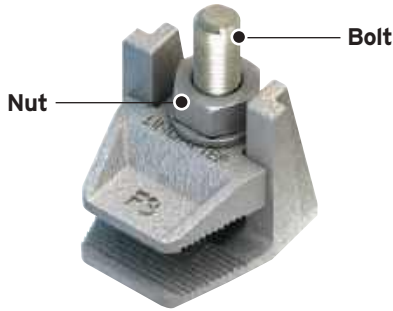

For heavier loads or wider clamping range, please see the Type F9 on page 38.

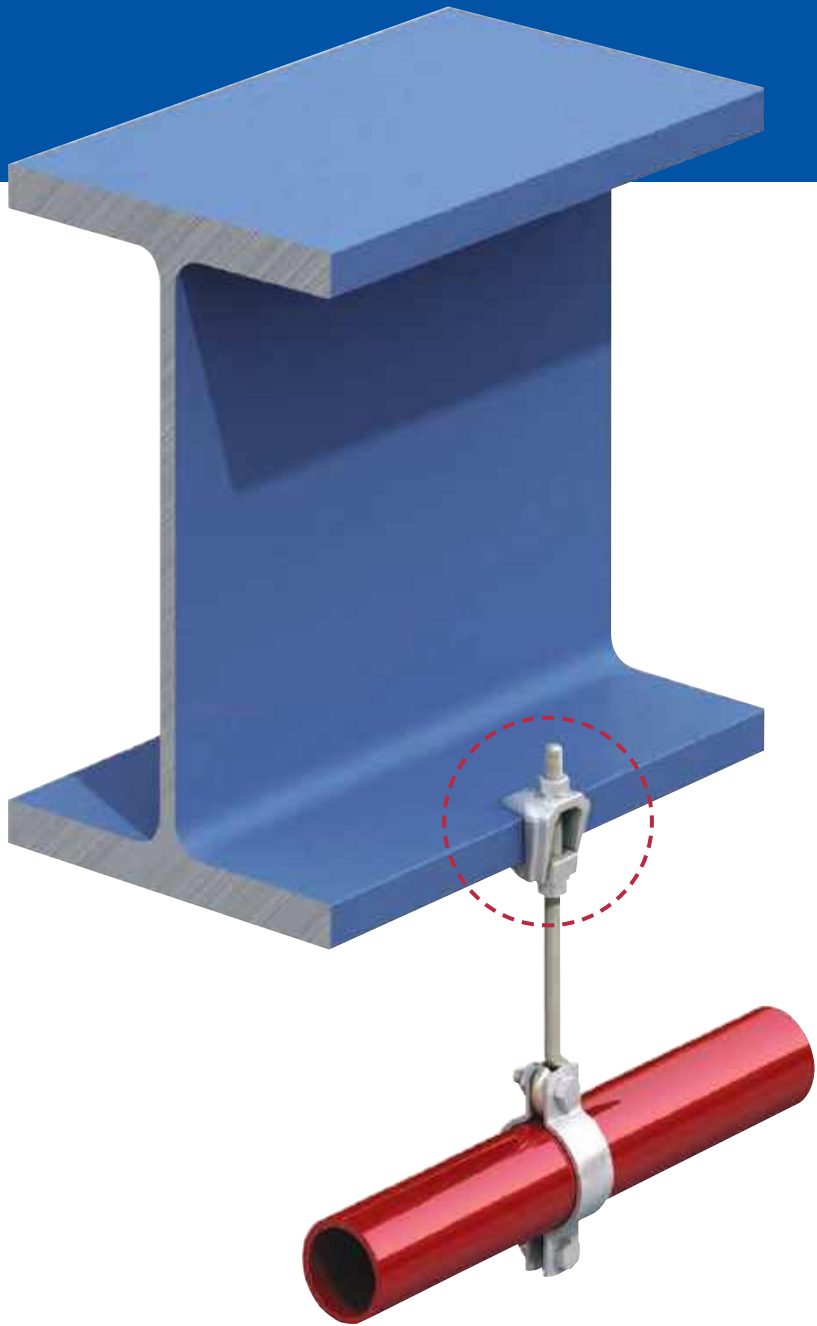

Material: Malleable iron, hot dip galvanized.

Without Bolt Product Code	With Bolt		Safe Working Load (FOS 4:1) Tensile lbs	Clamping Range W	Tightening Torque* ft lb	Dimensions				
	Product Code	Bolt Supplied Z				S	T	V	X	Width R
LF3037NB	LF3037WB	M10 (3/8")	270	1/16" - 13/16"	15	7/8"	5/16"	3/8"	1"	1 1/2"
LF3050NB	LF3050WB	M12 (1/2")	450	1/16" - 19/16"	29	1 1/8"	3/8"	1/2"	1 3/8"	1 15/16"
LF3062NB	LF3062WB	M16 (5/8")	900	1/8" - 2 3/16"	69	1 7/16"	1/2"	5/8"	1 13/16"	2 3/8"
LF3075NB	LF3075WB	M20 (3/4")	1350	3/16" - 2 3/4"	130	1 3/4"	9/16"	3/4"	2 3/16"	3"

* Torque figures based on fasteners in an unlubricated condition. For further information see page 78.

- For parallel flanges only.
- Supplied without bolt or with bolt (contact your local distributor for details / options).

GIRDER CLAMPS
LIFTING POINTS
HOLLO-BOLT
FLOOR CONNECTIONS
PIPE SUPPORTS
FAQS & CASE STUDIES

Type HW / HC

For vertical suspension on angled surfaces of up to 10° swing either side of the vertical.

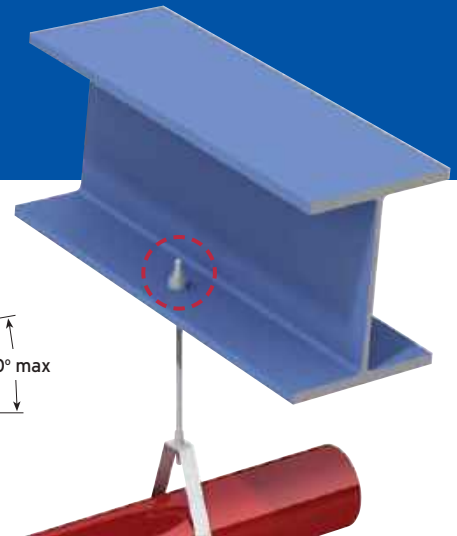
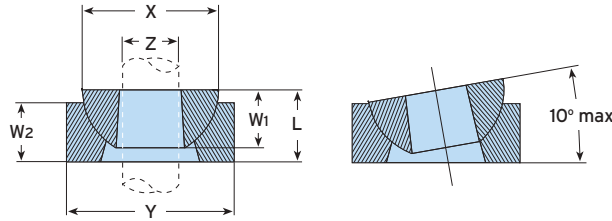

Material: Malleable iron, zinc plated or hot dip galvanized.

Product Code		Rod Z	Dimensions				
Hemispherical Washer (can be used without cup)	Hemispherical Cup		Hemispherical Washer X	W ₁	Hemispherical Cup Y	W ₂	Hemispherical Washer & Cup L
LHW037	LHC037	3/8"	1 1/32"	7/16"	1 9/32"	1/2"	5/8"
LHW050	LHC050	1/2"	1 1/8"	1/2"	1 11/32"	1/2"	1 1/16"
LHW062	LHC062	5/8"	1 3/8"	5/8"	1 5/8"	5/8"	7/8"
LHW075	LHC075	3/4"	1 3/4"	23/32"	2 5/32"	3/4"	2 9/32"

Type TC - Toggle Clamp

Designed for service suspension from pre-cast hollow core slabs (minimum core depth 3").



Material: Steel strip, zinc plated.

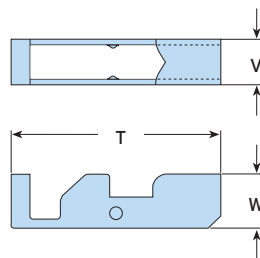

➔ Safe Working Loads subject to the strength of the supporting section.

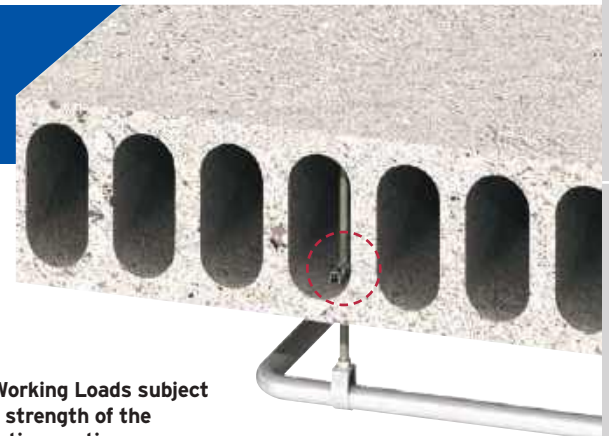

Product Code	Drop Rod	Hole Ø	Safe Working Load (FOS 4:1)		Dimensions		
			Tensile / 1 Rod lbs	Tightening Torque ft lb	T	W	Width V
LTC037	3/8" UNC	1"	550	7	2 11/16"	1 1/16"	9/16"



How to install...

▶ Watch the installation at www.Lindapter.com

Instructions for hollow core slab:

- 1) Pre-assemble the clamp on the rod and insert into the hole (ensure it is central to the hollow core).
- 2) Shake the rod to allow the toggle body to locate horizontally across the hole, then lower the rod so that the nut locates in the toggle body.
- 3) Wind up the rod to the top of the section so it is as high as possible. Secure the assembly with a nut and washer.

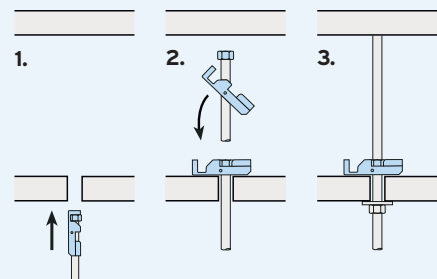

Tightening Torque and DTI Washers

Important information about the tightening torque values published in this catalog can be found below. Additional information about the use of DTI Washers is also provided.



Tightening Torque Values

All torque figures given in this catalog are for fasteners in an **unlubricated condition**. The use of these torque figures with lubricated or greased threaded fasteners and hexagon nuts will apply a much higher preload and may result in damage to the clamp and fastener. When using lubricated fasteners with a Lindapter component, a reduced torque value should be used. Please contact your bolt and nut supplier for information on the alternative torque for the selected lubricant to ensure the correct preload is generated.

Using DTI Washers

If preferred, DTI washers can be used as part of the fastener assembly with the components shown in the table below. The use of this type of washer can be used with lubricated fasteners and provides a visual indication that the correct preload has been achieved in the bolt. Alternatively, Tension Control Bolts in accordance with ASTM F959 may be used with the Type AF/AAF.



Lindapter Product	Bolt Grade	DTI Washer (ASTM F959)	
		Standard Connection	ICC-ES Approved Connection
Type AAF 	A325 or A490	Suggested	Required
Type AF 	A325 or A490	Suggested	Required
Type CF 	A325	Suggested	Not Applicable

► Other Lindapter products have lower torque values to limit the amount of preload on unlubricated bolts and cannot be used with DTI washers.

Product Durability

The durability of the Lindapter product is achieved by coating or by use of stainless steel and is categorized by Corrosivity Class in accordance with ISO 9223. For Corrosivity Class C4 and C5 please contact Lindapter.

Corrosivity Class	Galvanized Steel	Steel with Sheraplex finish	Electro-plated Steel + JS500	Electro-plated Steel	Stainless Steel
C1	more than 50 years	more than 50 years	more than 50 years	more than 20 years	more than 50 years
C2	more than 50 years	more than 50 years	more than 20 years	more than 5 years	more than 50 years
C3	more than 20 years	more than 20 years	more than 10 years	Not suitable	more than 50 years

► For Corrosivity Class information, see www.steelconstruction.info/Standard_corrosion_protection_systems_for_buildings

FAQs about Lindapter Girder Clamps

Below you'll find answers to the questions we get asked the most about Lindapter Girder Clamps. If your question is not answered here please contact Lindapter's Technical Support team.

Can location plates be made to any dimensions?

No. Details of the minimum sizes are shown in this catalog and on the website.

Are Lindapter assemblies reusable?

If an assembly which has not been subjected to dynamic or fatigue loading is repositioned and reused, a visual inspection should be carried out to check the condition of the components and the protective coating.

If any signs of physical damage or corrosion to the clamps or plates can be seen, the full assembly should be replaced.

Do tail length and packing combination calculations have to be exact?

The tables within the catalog or on the website should be used for guidance on tail lengths and packing combinations; there is a tolerance which varies depending on the bolt diameter.

Is it possible to use Lindapter products with proprietary concrete anchors?

Yes, but it may be necessary to reduce Lindapter's recommended bolt tightening torque to comply with the anchor bolt manufacturers figures; if so, this is likely to affect the connection capacity.

Will clamps damage my steel surface coating?

The material from which Lindapter clamps are manufactured should not damage the structure although removal marks could be in evidence on some surface coatings.

Can Lindapter connections be used in a combined tension and friction / slip resistance load?

For Lindapter products with both tension and slip loads published, combined loading is permitted. Please refer to AISC 360 for details.

Why do location and end plates have to be made to a certain minimum thickness?

As well as positioning all the components, the location plate supports the tail of the clamp. On girder clamp assemblies the plate does not have to be as thick as it does for end plates; the reason for this is that the tail of the clamp on the bottom beam is trying to bend the plate but this is counteracted by the clamp's tail on the top beam.

With end plates there is no counteracting clamp, hence the plate needs to be thicker to support the tail. Plate thicknesses may be able to be reduced by using higher grade/strength material.

Are Lindapter assemblies affected by vibration?

Although tested and approved for situations where they will be subject to vibration conditions, we would recommend that, in circumstances where this could be extreme, a proprietary locking device / anti-vibration washer can be used.

Can Lindapter Type F9 be used to connect beams together?

It is possible if the beams are running parallel to each other but they must be of the same type and width although a Lindapter Girder Clamp is a much better option; the Type F9 must never be used to connect beams together which are crossing at 90° to each other or have tapered flanges.

Can Lindapter assemblies be used as permanent connections or are they only for temporary use?

They can be used in temporary and permanent applications. Lindapter has details of applications that have been installed for 50 years or more.

FAQs about Lindapter Girder Clamps (continued)

Below you'll find more answers to the questions we get asked the most about Lindapter Girder Clamps. If your question is not answered here please contact Lindapter's Technical Support team.

How long will Lindapter assemblies last in an exterior environment?

The best coating would be Hot Dip Galvanizing. Longevity would depend on the background corrosion rate evident in the location it is intended they be used; guidance should be sought from the galvanizers association of the relevant country.

Is it possible to use stainless steel fasteners with Lindapter products?

It is not recommended as it is likely to create a mechanism for the onset of bi-metallic corrosion. They can however be used with the Lindapter Type LS which is manufactured in stainless steel.

Why is there such a high 'Factor of Safety', typically 5:1, on Lindapter connections?

This recommended 'Factor of Safety' is to ensure that the components are subject to loads well within their capacity range in normal working condition but in event of an unintentional overload of the component / assembly there is sufficient strength within the clamps to avoid damage and / or failure of the connection. A lower FOS must not be used without first seeking advice.

Why is the frictional Factor of Safety on Lindapter Type AF only 2:1 and not 5:1 as it is on the tensile Safe Working Loads?

The published safe working load and 2:1 factor of safety is a recognized method of determining slip and is defined according to the Eurocode as the load corresponding to 0.004" (0.1mm) of movement. As the safe working load is based on movement of 0.004" it is acceptable to use a reduced factor of safety of 2:1.

Do I need to use a torque wrench when assembling a Lindapter connection?

Yes, we always recommend the use of a calibrated torque wrench. It is important to tighten up the fasteners to our published torque figures to ensure it replicates test conditions so that the Safe Working Loads can be achieved.

Can I use Lindapter clamps in slotted hole connections?

Yes, but it is important that the slot is 'bridged' to ensure that the tail of the clamp does not fit into it. This can be done by using a product with a full width tail such as Types AAF, AF, LR or LS.

For additional guidance on slotted holes, please refer to AISC Section J3 and the RCSC.

Is it possible to use Lindapter products either sub-sea or within the splash zone?

Yes, although consideration has to be given to the proposed material or coating used; splash zones can be more aggressive than total submersion.

What is the recommended Lindapter safe working temperature range?

As a general rule -22°F to +662°F; however, this can increase or decrease in certain situations. For example, the Type AAF clamp is tested to -76°F. Carbon steel Hollo-Bolts have been tested to -50°F.

What should be considered when connecting a pre-drilled section to an existing beam?

Make sure the section is thick enough to counter the reaction from the tail of the clamp. The thickness shall be at least as thick as the designated end plate thickness for the specified clamp.

FAQs about Lindapter Hollo-Bolts

Below you'll find answers to the questions we get asked the most about Lindapter Hollo-Bolts. If your question is not answered here please contact Lindapter's Technical Support team.

Can the Hollo-Bolt be used in concrete?

No. It is designed as an expansion bolt for HSS of all shapes and sizes or where access is available from one side only.

Why is there a minimum outer ply requirement when using 5/8" and 3/4" Hollo-Bolts?

To ensure the unique collapse mechanism (rubber washer) does not compromise the shear capacity of the Hollo-Bolt by being within the shear plane.

Is it possible to reuse the Hollo-Bolt?

No, although a new Hollo-Bolt can be inserted in the existing hole.

Is it necessary to seal the Hollo-Bolt to prevent ingress of water?

This is not always necessary especially on the larger size 5/8" and 3/4" Hollo-Bolt HCFs where the collapse mechanism (rubber washer) expands to fill the void. Sealing washers are available; however, it is important the interface between the HSS face and plate or bracket is not ignored.

Can I use slotted holes in Hollo-Bolt connections?

Yes, as long as the slot is in the outer ply only and is perpendicular to the shear load. Refer to the RCSC for additional washer requirements. Please note the Hollo-Bolt has not been tested in slip-critical connections.

Which Hollo-Bolt load table should I use?

For simple connections with unfactored loads use the capacity figures shown on pages 58-63 (5:1 Factor of Safety). The Hollo-Bolt LRFD and ASD Design Strengths figures on pages 50-55 (taken from ESR-3330) are to be used only when designing a bolted connection to **AISC 360**, **AISC 341**, and **ASCE/SEI 7** as referenced by the locally adopted building code.

Can the Hollo-Bolt be used in all shapes and sizes of HSS?

Yes. It can be used in square, rectangular, circular, and other profiles where access is restricted to the outer face. In all cases however the suitability of the component is subject to the available void space, the total thickness of the material to be clamped and in the case of circular sections, the radius of the outer face.

Is it possible, however slightly, to exceed the maximum Hollo-Bolt clamping thicknesses published in the catalog?

No. The figures are accurate depictions and should not be exceeded under any circumstances.

How do I remove a Hollo-Bolt?

Using a power / hand tool to remove a pre-installed Hexagonal or Countersunk Hollo-Bolt (sizes 5/16", 3/8" and 1/2"):

- 1) Set the power / hand tool to reverse mode (anti-clockwise rotation).
- 2) Place a suitable size wrench (depending on collar size) on the flats of the collar to hold in place.
- 3) Use the power / hand tool to loosen the bolt.
- 4) Continue in reverse mode until the cone on the inside of the HSS at the other end of the bolt, is released to drop inside the HSS.
- 5) The bolt can now be removed as can the sleeve by prying the collar with a pinch or crow bar.

Using a power / hand tool to remove a pre-installed Hollo-Bolt High Clamping Force (sizes 5/8" and 3/4"):

- Steps 1) to 3) same as above.
- 4) Continue in reverse mode until the cone, expanded sleeve, and rubber washer on the inside of the HSS, at the other end of the bolt are released to drop inside the HSS.
 - 5) The bolt and loose collar can now be removed.

Structural Sections

Lindapter's products are compatible with almost any type of steel section. Properties of popular beams and channels are included over the next six pages. While this is not a definitive list of all steel sections, it may be a convenient reference point for Engineers.

Wide Flange Beams

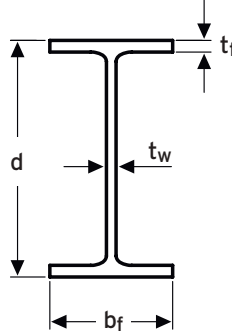

Section Designation	Nominal Weight	Section				Thickness			
		Depth d		Width bf		Web tw		Flange tf	
	lb/ft	in.		in.		in.		in.	
W44X335	335	44.0	44	15.9	16	1.03	1	1.77	13/4
W44X290	290	43.6	43 5/8	15.8	15 7/8	0.865	7/8	1.58	19/16
W44X262	262	43.3	43 1/4	15.8	15 3/4	0.785	13/16	1.42	17/16
W44X230	230	42.9	42 7/8	15.8	15 3/4	0.710	11/16	1.22	1 1/4
W40X655	655	43.6	43 5/8	16.9	16 7/8	1.97	2	3.54	3 9/16
W40X593	593	43.0	43	16.7	16 3/4	1.79	1 13/16	3.23	3 1/4
W40X503	503	42.1	42	16.4	16 3/8	1.54	1 9/16	2.76	2 3/4
W40X431	431	41.3	41 1/4	16.2	16 1/4	1.34	1 5/16	2.36	2 3/8
W40X397	397	41.0	41	16.1	16 1/8	1.22	1 1/4	2.20	2 3/16
W40X372	372	40.6	40 5/8	16.1	16 1/8	1.16	1 3/16	2.05	2 1/16
W40X362	362	40.6	40 1/2	16.0	16	1.12	1 1/8	2.01	2
W40X324	324	40.2	40 1/8	15.9	15 7/8	1.00	1	1.81	1 13/16
W40X297	297	39.8	39 7/8	15.8	15 7/8	0.930	15/16	1.65	1 5/8
W40X277	277	39.7	39 3/4	15.8	15 7/8	0.830	13/16	1.58	1 9/16
W40X249	249	39.4	39 3/8	15.8	15 3/4	0.750	3/4	1.42	1 7/16
W40X215	215	39.0	39	15.8	15 3/4	0.650	5/8	1.22	1 1/4
W40X199	199	38.7	38 5/8	15.8	15 3/4	0.650	5/8	1.07	1 1/16
W40X392	392	41.6	41 5/8	12.4	12 3/8	1.42	1 7/16	2.52	2 1/2
W40X331	331	40.8	40 3/4	12.2	12 1/8	1.22	1 1/4	2.13	2 1/8
W40X327	327	40.8	40 3/4	12.1	12 1/8	1.18	1 3/16	2.13	2 1/8
W40X294	294	40.4	40 3/8	12.0	12	1.06	1 1/16	1.93	1 15/16
W40X278	278	40.2	40 1/8	12.0	12	1.03	1	1.81	1 13/16
W40X264	264	40.0	40	11.9	11 7/8	0.960	15/16	1.73	1 3/4
W40X235	235	39.7	39 3/4	11.9	11 7/8	0.830	13/16	1.58	1 9/16
W40X211	211	39.4	39 3/8	11.8	11 3/4	0.750	3/4	1.42	1 7/16
W40X183	183	39.0	39	11.8	11 3/4	0.650	5/8	1.20	1 3/16
W40X167	167	38.6	38 5/8	11.8	11 3/4	0.650	5/8	1.03	1
W40X149	149	38.2	38 1/4	11.8	11 3/4	0.630	5/8	0.830	1 3/16
W36X925	925	43.1	43 1/8	18.6	18 5/8	3.02	3	4.53	4 1/2
W36X853	853	43.1	43 1/8	18.2	18 1/4	2.52	2 1/2	4.53	4 1/2
W36X802	802	42.6	42 5/8	18.0	18	2.38	2 3/8	4.29	4 5/16
W36X723	723	41.8	41 3/4	17.8	17 3/4	2.17	2 3/16	3.90	3 7/8

Section Designation	Nominal Weight	Section				Thickness			
		Depth d		Width bf		Web tw		Flange tf	
	lb/ft	in.		in.		in.		in.	
W36X652	652	41.1	41	17.6	17 5/8	1.97	2	3.54	3 9/16
W36X529	529	39.8	39 3/4	17.2	17 1/4	1.61	1 5/8	2.91	2 15/16
W36X487	487	39.3	39 3/8	17.1	17 1/8	1.50	1 1/2	2.68	2 11/16
W36X441	441	38.9	38 7/8	17.0	17	1.36	1 3/8	2.44	2 7/16
W36X395	395	38.4	38 3/8	16.8	16 7/8	1.22	1 1/4	2.20	2 3/16
W36X361	361	38.0	38	16.7	16 3/4	1.12	1 1/8	2.01	2
W36X330	330	37.7	37 5/8	16.6	16 5/8	1.02	1	1.85	1 7/8
W36X302	302	37.3	37 3/8	16.7	16 5/8	0.945	15/16	1.68	1 11/16
W36X282	282	37.1	37 1/8	16.6	16 5/8	0.885	7/8	1.57	1 9/16
W36X262	262	36.9	36 7/8	16.6	16 1/2	0.840	13/16	1.44	1 7/16
W36X247	247	36.7	36 5/8	16.5	16 1/2	0.800	13/16	1.35	1 3/8
W36X231	231	36.5	36 1/2	16.5	16 1/2	0.760	3/4	1.26	1 1/4
W36X256	256	37.4	37 3/8	12.2	12 1/4	0.960	15/16	1.73	1 3/4
W36X232	232	37.1	37 1/8	12.1	12 1/8	0.870	7/8	1.57	1 9/16
W36X210	210	36.7	36 3/4	12.2	12 1/8	0.830	13/16	1.36	1 3/8
W36X194	194	36.5	36 1/2	12.1	12 1/8	0.765	3/4	1.26	1 1/4
W36X182	182	36.3	36 3/8	12.1	12 1/8	0.725	3/4	1.18	1 3/16
W36X170	170	36.2	36 1/8	12.0	12	0.680	11/16	1.10	1 1/8
W36X160	160	36.0	36	12.0	12	0.650	5/8	1.02	1
W36X150	150	35.9	35 7/8	12.0	12	0.625	5/8	0.940	15/16
W36X135	135	35.6	35 1/2	12.0	12	0.600	5/8	0.790	13/16
W33X387	387	36.0	36	16.2	16 1/4	1.26	1 1/4	2.28	2 1/4
W33X354	354	35.6	35 1/2	16.1	16 1/8	1.16	1 3/16	2.09	2 1/16
W33X318	318	35.2	35 1/8	16.0	16	1.04	1 1/16	1.89	1 7/8
W33X291	291	34.8	34 7/8	15.9	15 7/8	0.960	15/16	1.73	1 3/4
W33X263	263	34.5	34 1/2	15.8	15 3/4	0.870	7/8	1.57	1 9/16
W33X241	241	34.2	34 1/8	15.9	15 7/8	0.830	13/16	1.40	1 3/8
W33X221	221	33.9	33 7/8	15.8	15 3/4	0.775	3/4	1.28	1 1/4
W33X201	201	33.7	33 5/8	15.7	15 3/4	0.715	11/16	1.15	1 1/8
W33X169	169	33.8	33 7/8	11.5	11 1/2	0.670	11/16	1.22	1 1/4
W33X152	152	33.5	33 1/2	11.6	11 5/8	0.635	5/8	1.06	1 1/16
W33X141	141	33.3	33 1/4	11.5	11 1/2	0.605	5/8	0.960	15/16

Source: AISC Construction Manual (15th Ed.) & Shapes Database (v15.0). Copyright © American Institute of Steel Construction. Reprinted with permission. All rights reserved. For additional dimensions and section details, refer to the latest AISC Shapes Database (www.aisc.org/publications/steel-construction-manual-resources).

GIRDER CLAMPS

LIFTING POINTS

HOLLO-BOLT

FLOOR CONNECTIONS

PIPE SUPPORTS

FAQS & CASE STUDIES

Structural Sections

(Continued).

Wide Flange Beams (continued)

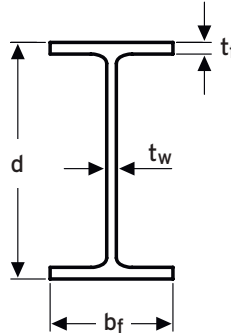

Section Designation	Nominal Weight	Section				Thickness			
		Depth d		Width bf		Web tw		Flange tf	
	lb/ft	in.		in.		in.		in.	
W33X130	130	33.1	33 1/8	11.5	11 1/2	0.580	9/16	0.855	7/8
W33X118	118	32.9	32 7/8	11.5	11 1/2	0.550	9/16	0.740	3/4
W30X391	391	33.2	33 1/4	15.6	15 5/8	1.36	1 3/8	2.44	2 7/16
W30X357	357	32.8	32 3/4	15.5	15 1/2	1.24	1 1/4	2.24	2 1/4
W30X326	326	32.4	32 3/8	15.4	15 3/8	1.14	1 1/8	2.05	2 1/16
W30X292	292	32.0	32	15.3	15 1/4	1.02	1	1.85	1 7/8
W30X261	261	31.6	31 5/8	15.2	15 1/8	0.930	15/16	1.65	1 5/8
W30X235	235	31.3	31 1/4	15.1	15	0.830	13/16	1.50	1 1/2
W30X211	211	30.9	31	15.1	15 1/8	0.775	3/4	1.32	1 5/16
W30X191	191	30.7	30 5/8	15.0	15	0.710	11/16	1.19	1 3/16
W30X173	173	30.4	30 1/2	15.0	15	0.655	5/8	1.07	1 1/16
W30X132	132	30.3	30 1/4	10.5	10 1/2	0.615	5/8	1.00	1
W30X124	124	30.2	30 1/8	10.5	10 1/2	0.585	9/16	0.930	15/16
W30X116	116	30.0	30	10.5	10 1/2	0.565	9/16	0.850	7/8
W30X108	108	29.8	29 7/8	10.5	10 1/2	0.545	9/16	0.760	3/4
W30X99	99.0	29.7	29 5/8	10.5	10 1/2	0.520	1/2	0.670	11/16
W30X90	90.0	29.5	29 1/2	10.4	10 3/8	0.470	1/2	0.610	5/8
W27X539	539	32.5	32 1/2	15.3	15 1/4	1.97	2	3.54	3 9/16
W27X368	368	30.4	30 3/8	14.7	14 5/8	1.38	1 3/8	2.48	2 1/2
W27X336	336	30.0	30	14.6	14 1/2	1.26	1 1/4	2.28	2 1/4
W27X307	307	29.6	29 5/8	14.4	14 1/2	1.16	1 3/16	2.09	2 1/16
W27X281	281	29.3	29 1/4	14.4	14 3/8	1.06	1 1/16	1.93	1 15/16
W27X258	258	29.0	29	14.3	14 1/4	0.980	1	1.77	1 3/4
W27X235	235	28.7	28 5/8	14.2	14 1/4	0.910	15/16	1.61	1 5/8
W27X217	217	28.4	28 3/8	14.1	14 1/8	0.830	13/16	1.50	1 1/2
W27X194	194	28.1	28 1/8	14.0	14	0.750	3/4	1.34	1 5/16
W27X178	178	27.8	27 3/4	14.1	14 1/8	0.725	3/4	1.19	1 3/16
W27X161	161	27.6	27 5/8	14.0	14	0.660	11/16	1.08	1 1/16
W27X146	146	27.4	27 3/8	14.0	14	0.605	5/8	0.975	1
W27X129	129	27.6	27 5/8	10.0	10	0.610	5/8	1.10	1 1/8
W27X114	114	27.3	27 1/4	10.1	10 1/8	0.570	9/16	0.930	15/16
W27X102	102	27.1	27 1/8	10.0	10	0.515	1/2	0.830	13/16
W27X94	94.0	26.9	26 7/8	10.0	10	0.490	1/2	0.745	3/4
W27X84	84.0	26.7	26 3/4	10.0	10	0.460	7/16	0.640	5/8
W24X370	370	28.0	28	13.7	13 5/8	1.52	1 1/2	2.72	2 3/4
W24X335	335	27.5	27 1/2	13.5	13 1/2	1.38	1 3/8	2.48	2 1/2
W24X306	306	27.1	27 1/8	13.4	13 3/8	1.26	1 1/4	2.28	2 1/4
W24X279	279	26.7	26 3/4	13.3	13 1/4	1.16	1 3/16	2.09	2 1/16
W24X250	250	26.3	26 3/8	13.2	13 1/8	1.04	1 1/16	1.89	1 7/8
W24X229	229	26.0	26	13.1	13 1/8	0.960	15/16	1.73	1 3/4
W24X207	207	25.7	25 3/4	13.0	13	0.870	7/8	1.57	1 9/16
W24X192	192	25.5	25 1/2	13.0	13	0.810	13/16	1.46	1 7/16
W24X176	176	25.2	25 1/4	12.9	12 7/8	0.750	3/4	1.34	1 5/16
W24X162	162	25.0	25	13.0	13	0.705	11/16	1.22	1 1/4
W24X146	146	24.7	24 3/4	12.9	12 7/8	0.650	5/8	1.09	1 1/16
W24X131	131	24.5	24 1/2	12.9	12 7/8	0.605	5/8	0.960	15/16
W24X117	117	24.3	24 1/4	12.8	12 3/4	0.550	9/16	0.850	7/8
W24X104	104	24.1	24	12.8	12 3/4	0.500	1/2	0.750	3/4
W24X103	103	24.5	24 1/2	9.00	9	0.550	9/16	0.980	1
W24X94	94.0	24.3	24 1/4	9.07	9 1/8	0.515	1/2	0.875	7/8
W24X84	84.0	24.1	24 1/8	9.02	9	0.470	1/2	0.770	3/4
W24X76	76.0	23.9	23 7/8	8.99	9	0.440	7/16	0.680	11/16
W24X68	68.0	23.7	23 3/4	8.97	9	0.415	7/16	0.585	9/16
W24X62	62.0	23.7	23 3/4	7.04	7	0.430	7/16	0.590	9/16
W24X55	55.0	23.6	23 5/8	7.01	7	0.395	3/8	0.505	1/2
W21X275	275	24.1	24 1/8	12.9	12 7/8	1.22	1 1/4	2.19	2 3/16
W21X248	248	23.7	23 3/4	12.8	12 3/4	1.10	1 1/8	1.99	2
W21X223	223	23.4	23 3/8	12.7	12 5/8	1.00	1	1.79	1 13/16
W21X201	201	23.0	23	12.6	12 5/8	0.910	15/16	1.63	1 5/8
W21X182	182	22.7	22 3/4	12.5	12 1/2	0.830	13/16	1.48	1 1/2
W21X166	166	22.5	22 1/2	12.4	12 3/8	0.750	3/4	1.36	1 3/8
W21X147	147	22.1	22	12.5	12 1/2	0.720	3/4	1.15	1 1/8
W21X132	132	21.8	21 7/8	12.4	12 1/2	0.650	5/8	1.04	1 1/16
W21X122	122	21.7	21 5/8	12.4	12 3/8	0.600	5/8	0.960	15/16

Source: AISC Construction Manual (15th Ed.) & Shapes Database (v15.0). Copyright © American Institute of Steel Construction. Reprinted with permission. All rights reserved. For additional dimensions and section details, refer to the latest AISC Shapes Database (www.aisc.org/publications/steel-construction-manual-resources).

Structural Sections

(Continued).

Wide Flange Beams (continued)

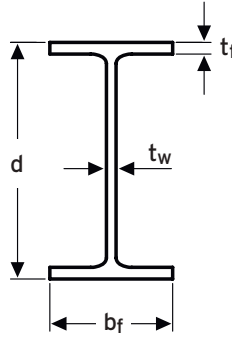

Section Designation	Nominal Weight	Section				Thickness			
		Depth d		Width bf		Web tw		Flange tf	
		lb/ft	in.	in.	in.	in.	in.	in.	in.
W21X111	111	21.5	21 1/2	12.3	12 3/8	0.550	9/16	0.875	7/8
W21X101	101	21.4	21 3/8	12.3	12 1/4	0.500	1/2	0.800	13/16
W21X93	93.0	21.6	21 5/8	8.42	8 3/8	0.580	9/16	0.930	15/16
W21X83	83.0	21.4	21 3/8	8.36	8 3/8	0.515	1/2	0.835	13/16
W21X73	73.0	21.2	21 1/4	8.30	8 1/4	0.455	7/16	0.740	3/4
W21X68	68.0	21.1	21 1/8	8.27	8 1/4	0.430	7/16	0.685	11/16
W21X62	62.0	21.0	21	8.24	8 1/4	0.400	3/8	0.615	5/8
W21X55	55.0	20.8	20 3/4	8.22	8 1/4	0.375	3/8	0.522	1/2
W21X48	48.0	20.6	20 5/8	8.14	8 1/8	0.350	3/8	0.430	7/16
W21X57	57.0	21.1	21	6.56	6 1/2	0.405	3/8	0.650	5/8
W21X50	50.0	20.8	20 7/8	6.53	6 1/2	0.380	3/8	0.535	9/16
W21X44	44.0	20.7	20 5/8	6.50	6 1/2	0.350	3/8	0.450	7/16
W18X311	311	22.3	22 3/8	12.0	12	1.52	1 1/2	2.74	2 3/4
W18X283	283	21.9	21 7/8	11.9	11 7/8	1.40	1 3/8	2.50	2 1/2
W18X258	258	21.5	21 1/2	11.8	11 3/4	1.28	1 1/4	2.30	2 5/16
W18X234	234	21.1	21	11.7	11 5/8	1.16	1 3/16	2.11	2 1/8
W18X211	211	20.7	20 5/8	11.6	11 1/2	1.06	1 1/16	1.91	1 15/16
W18X192	192	20.4	20 3/8	11.5	11 1/2	0.960	15/16	1.75	1 3/4
W18X175	175	20.0	20	11.4	11 3/8	0.890	7/8	1.59	1 9/16
W18X158	158	19.7	19 3/4	11.3	11 1/4	0.810	13/16	1.44	1 7/16
W18X143	143	19.5	19 1/2	11.2	11 1/4	0.730	3/4	1.32	1 5/16
W18X130	130	19.3	19 1/4	11.2	11 1/8	0.670	11/16	1.20	1 3/16
W18X119	119	19.0	19	11.3	11 1/4	0.655	5/8	1.06	1 1/16
W18X106	106	18.7	18 3/4	11.2	11 1/4	0.590	9/16	0.940	15/16
W18X97	97.0	18.6	18 5/8	11.1	11 1/8	0.535	9/16	0.870	7/8
W18X86	86.0	18.4	18 3/8	11.1	11 1/8	0.480	1/2	0.770	3/4
W18X76	76.0	18.2	18 1/4	11.0	11	0.425	7/16	0.680	11/16
W18X71	71.0	18.5	18 1/2	7.64	7 5/8	0.495	1/2	0.810	13/16
W18X65	65.0	18.4	18 3/8	7.59	7 5/8	0.450	7/16	0.750	3/4
W18X60	60.0	18.2	18 1/4	7.56	7 1/2	0.415	7/16	0.695	11/16
W18X55	55.0	18.1	18 1/8	7.53	7 1/2	0.390	3/8	0.630	5/8
W18X50	50.0	18.0	18	7.50	7 1/2	0.355	3/8	0.570	9/16

Section Designation	Nominal Weight	Section				Thickness			
		Depth d		Width bf		Web tw		Flange tf	
		lb/ft	in.	in.	in.	in.	in.	in.	in.
W18X46	46.0	18.1	18	6.06	6	0.360	3/8	0.605	5/8
W18X40	40.0	17.9	17 7/8	6.02	6	0.315	5/16	0.525	1/2
W18X35	35.0	17.7	17 3/4	6.00	6	0.300	5/16	0.425	7/16
W16X100	100	17.0	17	10.4	10 3/8	0.585	9/16	0.985	1
W16X89	89.0	16.8	16 3/4	10.4	10 3/8	0.525	1/2	0.875	7/8
W16X77	77.0	16.5	16 1/2	10.3	10 1/4	0.455	7/16	0.760	3/4
W16X67	67.0	16.3	16 3/8	10.2	10 1/4	0.395	3/8	0.665	11/16
W16X57	57.0	16.4	16 3/8	7.12	7 1/8	0.430	7/16	0.715	11/16
W16X50	50.0	16.3	16 1/4	7.07	7 1/8	0.380	3/8	0.630	5/8
W16X45	45.0	16.1	16 1/8	7.04	7	0.345	3/8	0.565	9/16
W16X40	40.0	16.0	16	7.00	7	0.305	5/16	0.505	1/2
W16X36	36.0	15.9	15 7/8	6.99	7	0.295	5/16	0.430	7/16
W16X31	31.0	15.9	15 7/8	5.53	5 1/2	0.275	1/4	0.440	7/16
W16X26	26.0	15.7	15 3/4	5.50	5 1/2	0.250	1/4	0.345	3/8
W14X873	873	23.6	23 5/8	18.8	18 3/4	3.94	3 15/16	5.51	5 1/12
W14X808	808	22.8	22 3/4	18.6	18 5/8	3.74	3 3/4	5.12	5 1/8
W14X730	730	22.4	22 3/8	17.9	17 7/8	3.07	3 1/16	4.91	4 15/16
W14X665	665	21.6	21 5/8	17.7	17 5/8	2.83	2 13/16	4.52	4 1/2
W14X605	605	20.9	20 7/8	17.4	17 3/8	2.60	2 5/8	4.16	4 3/16
W14X550	550	20.2	20 1/4	17.2	17 1/4	2.38	2 3/8	3.82	3 13/16
W14X500	500	19.6	19 5/8	17.0	17	2.19	2 3/16	3.50	3 1/2
W14X455	455	19.0	19	16.8	16 7/8	2.02	2	3.21	3 3/16
W14X426	426	18.7	18 5/8	16.7	16 3/4	1.88	1 7/8	3.04	3 1/16
W14X398	398	18.3	18 1/4	16.6	16 5/8	1.77	1 3/4	2.85	2 7/8
W14X370	370	17.9	17 7/8	16.5	16 1/2	1.66	1 11/16	2.66	2 11/16
W14X342	342	17.5	17 1/2	16.4	16 3/8	1.54	1 9/16	2.47	2 1/2
W14X311	311	17.1	17 1/8	16.2	16 1/4	1.41	1 7/16	2.26	2 1/4
W14X283	283	16.7	16 3/4	16.1	16 1/8	1.29	1 5/16	2.07	2 1/16
W14X257	257	16.4	16 3/8	16.0	16	1.18	1 3/16	1.89	1 7/8
W14X233	233	16.0	16	15.9	15 7/8	1.07	1 1/16	1.72	1 3/4
W14X211	211	15.7	15 3/4	15.8	15 3/4	0.980	1	1.56	1 9/16
W14X193	193	15.5	15 1/2	15.7	15 3/4	0.890	7/8	1.44	1 7/16

Source: AISC Construction Manual (15th Ed.) & Shapes Database (v15.0). Copyright © American Institute of Steel Construction. Reprinted with permission. All rights reserved. For additional dimensions and section details, refer to the latest AISC Shapes Database (www.aisc.org/publications/steel-construction-manual-resources).

GIRDER CLAMPS
LIFTING POINTS
HOLLO-BOLT
FLOOR CONNECTIONS
PIPE SUPPORTS
FAQS & CASE STUDIES

Structural Sections

(Continued).

Wide Flange Beams (continued)

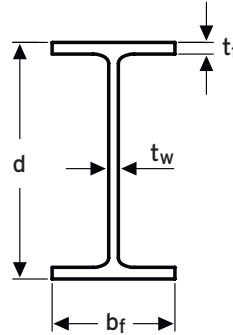

Section Designation	Nominal Weight	Section			Thickness				
		Depth d		Width b _f	Web t _w		Flange t _f		
	lb/ft	in.		in.		in.		in.	
W14X176	176	15.2	15 1/4	15.7	15 5/8	0.830	13/16	1.31	15/16
W14X159	159	15.0	15	15.6	15 5/8	0.745	3/4	1.19	13/16
W14X145	145	14.8	14 3/4	15.5	15 1/2	0.680	11/16	1.09	11/16
W14X132	132	14.7	14 5/8	14.7	14 3/4	0.645	5/8	1.03	1
W14X120	120	14.5	14 1/2	14.7	14 5/8	0.590	9/16	0.940	15/16
W14X109	109	14.3	14 3/8	14.6	14 5/8	0.525	1/2	0.860	7/8
W14X99	99.0	14.2	14 1/8	14.6	14 5/8	0.485	1/2	0.780	3/4
W14X90	90.0	14.0	14	14.5	14 1/2	0.440	7/16	0.710	11/16
W14X82	82.0	14.3	14 1/4	10.1	10 1/8	0.510	1/2	0.855	7/8
W14X74	74.0	14.2	14 1/8	10.1	10 1/8	0.450	7/16	0.785	13/16
W14X68	68.0	14.0	14	10.0	10	0.415	7/16	0.720	3/4
W14X61	61.0	13.9	13 7/8	10.0	10	0.375	3/8	0.645	5/8
W14X53	53.0	13.9	13 7/8	8.06	8	0.370	3/8	0.660	11/16
W14X48	48.0	13.8	13 3/4	8.03	8	0.340	5/16	0.595	5/8
W14X43	43.0	13.7	13 5/8	8.00	8	0.305	5/16	0.530	1/2
W14X38	38.0	14.1	14 1/8	6.77	6 3/4	0.310	5/16	0.515	1/2
W14X34	34.0	14.0	14	6.75	6 3/4	0.285	5/16	0.455	7/16
W14X30	30.0	13.8	13 7/8	6.73	6 3/4	0.270	1/4	0.385	3/8
W14X26	26.0	13.9	13 7/8	5.03	5	0.255	1/4	0.420	7/16
W14X22	22.0	13.7	13 3/4	5.00	5	0.230	1/4	0.335	5/16
W12X336	336	16.8	16 7/8	13.4	13 3/8	1.78	13/4	2.96	2 15/16
W12X305	305	16.3	16 3/8	13.2	13 1/4	1.63	15/8	2.71	2 11/16
W12X279	279	15.9	15 7/8	13.1	13 1/8	1.53	1 1/2	2.47	2 1/2
W12X252	252	15.4	15 3/8	13.0	13	1.40	1 3/8	2.25	2 1/4
W12X230	230	15.1	15	12.9	12 7/8	1.29	15/16	2.07	2 1/16
W12X210	210	14.7	14 3/4	12.8	12 3/4	1.18	13/16	1.90	1 7/8
W12X190	190	14.4	14 3/8	12.7	12 5/8	1.06	1 1/16	1.74	1 3/4
W12X170	170	14.0	14	12.6	12 5/8	0.960	15/16	1.56	1 9/16
W12X152	152	13.7	13 3/4	12.5	12 1/2	0.870	7/8	1.40	1 3/8
W12X136	136	13.4	13 3/8	12.4	12 3/8	0.790	13/16	1.25	1 1/4
W12X120	120	13.1	13 1/8	12.3	12 3/8	0.710	1 1/16	1.11	1 1/8
W12X106	106	12.9	12 7/8	12.2	12 1/4	0.610	5/8	0.990	1
W12X96	96.0	12.7	12 3/4	12.2	12 1/8	0.550	9/16	0.900	7/8
W12X87	87.0	12.5	12 1/2	12.1	12 1/8	0.515	1/2	0.810	13/16
W12X79	79.0	12.4	12 3/8	12.1	12 1/8	0.470	1/2	0.735	3/4
W12X72	72.0	12.3	12 1/4	12.0	12	0.430	7/16	0.670	11/16
W12X65	65.0	12.1	12 1/8	12.0	12	0.390	3/8	0.605	5/8
W12X58	58.0	12.2	12 1/4	10.0	10	0.360	3/8	0.640	5/8
W12X53	53.0	12.1	12	10.0	10	0.345	3/8	0.575	9/16
W12X50	50.0	12.2	12 1/4	8.08	8 1/8	0.370	3/8	0.640	5/8
W12X45	45.0	12.1	12	8.05	8	0.335	5/16	0.575	9/16
W12X40	40.0	11.9	12	8.01	8	0.295	5/16	0.515	1/2
W12X35	35.0	12.5	12 1/2	6.56	6 1/2	0.300	5/16	0.520	1/2
W12X30	30.0	12.3	12 3/8	6.52	6 1/2	0.260	1/4	0.440	7/16
W12X26	26.0	12.2	12 1/4	6.49	6 1/2	0.230	1/4	0.380	3/8
W12X22	22.0	12.3	12 1/4	4.03	4	0.260	1/4	0.425	7/16
W12X19	19.0	12.2	12 1/8	4.01	4	0.235	1/4	0.350	3/8
W12X16	16.0	12.0	12	3.99	4	0.220	1/4	0.265	1/4
W12X14	14.0	11.9	11 7/8	3.97	4	0.200	3/16	0.225	1/4
W10X112	112	11.4	11 3/8	10.4	10 3/8	0.755	3/4	1.25	1 1/4
W10X100	100	11.1	11 1/8	10.3	10 3/8	0.680	11/16	1.12	1 1/8
W10X88	88.0	10.8	10 7/8	10.3	10 1/4	0.605	5/8	0.990	1
W10X77	77.0	10.6	10 5/8	10.2	10 1/4	0.530	1/2	0.870	7/8
W10X68	68.0	10.4	10 3/8	10.1	10 1/8	0.470	1/2	0.770	3/4
W10X60	60.0	10.2	10 1/4	10.1	10 1/8	0.420	7/16	0.680	11/16
W10X54	54.0	10.1	10 1/8	10.0	10	0.370	3/8	0.615	5/8
W10X49	49.0	10.0	10	10.0	10	0.340	5/16	0.560	9/16
W10X45	45.0	10.1	10 1/8	8.02	8	0.350	3/8	0.620	5/8
W10X39	39.0	9.92	9 7/8	7.99	8	0.315	5/16	0.530	1/2
W10X33	33.0	9.73	9 3/4	7.96	8	0.290	5/16	0.435	7/16
W10X30	30.0	10.5	10 1/2	5.81	5 3/4	0.300	5/16	0.510	1/2
W10X26	26.0	10.3	10 3/8	5.77	5 3/4	0.260	1/4	0.440	7/16
W10X22	22.0	10.2	10 1/8	5.75	5 3/4	0.240	1/4	0.360	3/8
W10X19	19.0	10.2	10 1/4	4.02	4	0.250	1/4	0.395	3/8

Source: AISC Construction Manual (15th Ed.) & Shapes Database (v15.0). Copyright © American Institute of Steel Construction. Reprinted with permission. All rights reserved. For additional dimensions and section details, refer to the latest AISC Shapes Database (www.aisc.org/publications/steel-construction-manual-resources).

Structural Sections

(Continued).

Wide Flange Beams (continued)

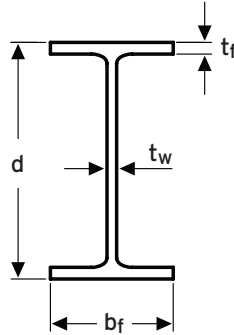

Standard Beams

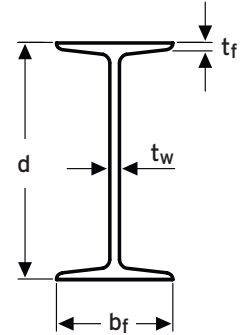

Section Designation	Nominal Weight lb/ft	Section				Thickness			
		Depth d in.	Width bf in.	Web tw in.	Flange tf in.				
W10X17	17.0	10.1	10 1/8	4.01	4	0.240	1/4	0.330	5/16
W10X15	15.0	9.99	10	4.00	4	0.230	1/4	0.270	1/4
W10X12	12.0	9.87	9 7/8	3.96	4	0.190	3/16	0.210	3/16
W8X67	67.0	9.00	9	8.28	8 1/4	0.570	9/16	0.935	15/16
W8X58	58.0	8.75	8 3/4	8.22	8 1/4	0.510	1/2	0.810	13/16
W8X48	48.0	8.50	8 1/2	8.11	8 1/8	0.400	3/8	0.685	11/16
W8X40	40.0	8.25	8 1/4	8.07	8 1/8	0.360	3/8	0.560	9/16
W8X35	35.0	8.12	8 1/8	8.02	8	0.310	5/16	0.495	1/2
W8X31	31.0	8.00	8	8.00	8	0.285	5/16	0.435	7/16
W8X28	28.0	8.06	8	6.54	6 1/2	0.285	5/16	0.465	7/16
W8X24	24.0	7.93	7 7/8	6.50	6 1/2	0.245	1/4	0.400	3/8
W8X21	21.0	8.28	8 1/4	5.27	5 1/4	0.250	1/4	0.400	3/8
W8X18	18.0	8.14	8 1/8	5.25	5 1/4	0.230	1/4	0.330	5/16
W8X15	15.0	8.11	8 1/8	4.02	4	0.245	1/4	0.315	5/16
W8X13	13.0	7.99	8	4.00	4	0.230	1/4	0.255	1/4
W8X10	10.0	7.89	7 7/8	3.94	4	0.170	3/16	0.205	3/16
W6X25	25.0	6.38	6 3/8	6.08	6 1/8	0.320	5/16	0.455	7/16
W6X20	20.0	6.20	6 1/4	6.02	6	0.260	1/4	0.365	3/8
W6X15	15.0	5.99	6	5.99	6	0.230	1/4	0.260	1/4
W6X16	16.0	6.28	6 1/4	4.03	4	0.260	1/4	0.405	3/8
W6X12	12.0	6.03	6	4.00	4	0.230	1/4	0.280	1/4
W6X9	9.00	5.90	5 7/8	3.94	4	0.170	3/16	0.215	3/16
W6X8.5	8.50	5.83	5 7/8	3.94	4	0.170	3/16	0.195	3/16
W5X19	19.0	5.15	5 1/8	5.03	5	0.270	1/4	0.430	7/16
W5X16	16.0	5.01	5	5.00	5	0.240	1/4	0.360	3/8
W4X13	13.0	4.16	4 1/8	4.06	4	0.280	1/4	0.345	3/8

Section Designation	Nominal Weight lb/ft	Section				Thickness			
		Depth d in.	Width bf in.	Web tw in.	Flange tf in.				
S24X121	121	24.5	24 1/2	8.05	8	0.800	13/16	1.09	11/16
S24X106	106	24.5	24 1/2	7.87	7 7/8	0.620	5/8	1.09	11/16
S24X100	100	24.0	24	7.25	7 1/4	0.745	3/4	0.870	7/8
S24X90	90.0	24.0	24	7.13	7 1/8	0.625	5/8	0.870	7/8
S24X80	80.0	24.0	24	7.00	7	0.500	1/2	0.870	7/8
S20X96	96.0	20.3	20 1/4	7.20	7 1/4	0.800	13/16	0.920	15/16
S20X86	86.0	20.3	20 1/4	7.06	7	0.660	11/16	0.920	15/16
S20X75	75.0	20.0	20	6.39	6 3/8	0.635	5/8	0.795	13/16
S20X66	66.0	20.0	20	6.26	6 1/4	0.505	1/2	0.795	13/16
S18X70	70.0	18.0	18	6.25	6 1/4	0.711	11/16	0.691	11/16
S18X54.7	54.7	18.0	18	6.00	6	0.461	7/16	0.691	11/16
S15X50	50.0	15.0	15	5.64	5 5/8	0.550	9/16	0.622	5/8
S15X42.9	42.9	15.0	15	5.50	5 1/2	0.411	7/16	0.622	5/8
S12X50	50.0	12.0	12	5.48	5 1/2	0.687	11/16	0.659	11/16
S12X40.8	40.8	12.0	12	5.25	5 1/4	0.462	7/16	0.659	11/16
S12X35	35.0	12.0	12	5.08	5 1/8	0.428	7/16	0.544	9/16
S12X31.8	31.8	12.0	12	5.00	5	0.350	3/8	0.544	9/16
S10X35	35.0	10.0	10	4.94	5	0.594	5/8	0.491	1/2
S10X25.4	25.4	10.0	10	4.66	4 5/8	0.311	5/16	0.491	1/2
S8X23	23.0	8.00	8	4.17	4 1/8	0.441	7/16	0.425	7/16
S8X18.4	18.4	8.00	8	4.00	4	0.271	1/4	0.425	7/16
S6X17.25	17.25	6.00	6	3.57	3 5/8	0.465	7/16	0.359	3/8
S6X12.5	12.5	6.00	6	3.33	3 3/8	0.232	1/4	0.359	3/8
S5X10	10.0	5.00	5	3.00	3	0.214	3/16	0.326	5/16
S4X9.5	9.50	4.00	4	2.80	2 3/4	0.326	5/16	0.293	5/16
S4X7.7	7.70	4.00	4	2.66	2 5/8	0.193	3/16	0.293	5/16
S3X7.5	7.50	3.00	3	2.51	2 1/2	0.349	3/8	0.260	1/4
S3X5.7	5.70	3.00	3	2.33	2 3/8	0.170	3/16	0.260	1/4

Source: AISC Construction Manual (15th Ed.) & Shapes Database (v15.0). Copyright © American Institute of Steel Construction. Reprinted with permission. All rights reserved. For additional dimensions and section details, refer to the latest AISC Shapes Database (www.aisc.org/publications/steel-construction-manual-resources).

GIRDER CLAMPS
LIFTING POINTS
HOLLO-BOLT
FLOOR CONNECTIONS
PIPE SUPPORTS
FAQS & CASE STUDIES

Structural Sections

(Continued).

Bearing Piles

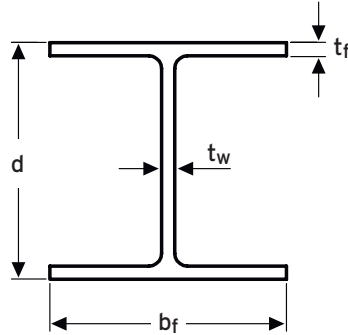

Section Designation	Nominal Weight	Section				Thickness			
		Depth d		Width b_f		Web t_w		Flange t_f	
	lb/ft	in.		in.		in.		in.	
HP18X204	204	18.3	18 1/4	18.1	18 1/8	1.13	1 1/8	1.13	1 1/8
HP18X181	181	18.0	18	18.0	18	1.00	1	1.00	1
HP18X157	157	17.7	17 3/4	17.9	17 7/8	0.870	7/8	0.870	7/8
HP18X135	135	17.5	17 1/2	17.8	17 3/4	0.750	3/4	0.750	3/4
HP16X183	183	16.5	16 1/2	16.3	16 1/2	1.13	1 1/8	1.13	1 1/8
HP16X162	162	16.3	16 1/4	16.1	16 1/8	1.00	1	1.00	1
HP16X141	141	16.0	16	16.0	16	0.875	7/8	0.875	7/8
HP16X121	121	15.8	15 3/4	15.9	15 7/8	0.750	3/4	0.750	3/4
HP16X101	101	15.5	15 1/2	15.8	15 3/4	0.625	5/8	0.625	5/8
HP16X88	88.0	15.3	15 3/8	15.7	15 11/16	0.540	9/16	0.540	9/16
HP14X117	117	14.2	14 1/4	14.9	14 7/8	0.805	13/16	0.805	13/16
HP14X102	102	14.0	14	14.8	14 3/4	0.705	11/16	0.705	11/16
HP14X89	89.0	13.8	13 7/8	14.7	14 3/4	0.615	5/8	0.615	5/8
HP14X73	73.0	13.6	13 5/8	14.6	14 5/8	0.505	1/2	0.505	1/2
HP12X89	89.0	12.4	12 3/8	12.3	12 3/8	0.720	3/4	0.720	3/4
HP12X84	84.0	12.3	12 1/4	12.3	12 1/4	0.685	11/16	0.685	11/16
HP12X74	74.0	12.1	12 1/8	12.2	12 1/4	0.605	5/8	0.610	5/8
HP12X63	63.0	11.9	12	12.1	12 1/8	0.515	1/2	0.515	1/2
HP12X53	53.0	11.8	11 3/4	12.0	12	0.435	7/16	0.435	7/16
HP10X57	57.0	9.99	10	10.2	10 1/4	0.565	9/16	0.565	9/16
HP10X42	42.0	9.70	9 3/4	10.1	10 1/8	0.415	7/16	0.420	7/16
HP8X36	36.0	8.02	8	8.16	8 1/8	0.445	7/16	0.445	7/16

Source: AISC Construction Manual (15th Ed.) & Shapes Database (v15.0). Copyright © American Institute of Steel Construction. Reprinted with permission. All rights reserved. For additional dimensions and section details, refer to the latest AISC Shapes Database (www.aisc.org/publications/steel-construction-manual-resources).

Proven connection solutions

Lindapter products are used in multiple industries around the world in an extensive range of applications. The case studies below highlight the wide use of Lindapter connections. To view more project examples please visit www.Lindapter.com

American Copper Buildings, NY

© Technic Photo



Product: Type AAF

Application: Connecting a steel grid to the structural beams on the sky-bridge structure.

The sky-pool is on the bottom floor of the three-story fitness and leisure complex, which bridges the gap between the two towers, high above New York City.

Engineers specified Lindapter's Type AAF clamps for connecting a steel grid to the trusses to create a frame for the façade panels to be installed onto the sky-bridge. Type AAF was chosen due to its high strength capacity and longevity.

The adjustability of the product allowed the contractors to quickly, align and secure the frame into position without drilling or welding, saving the contractors time and money on this prestigious project.

➔ See page 12 for Type AAF.

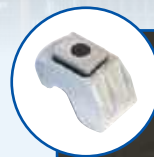

GIRDER CLAMPS

LIFTING POINTS

HOLLO-BOLT

FLOOR CONNECTIONS

PIPE SUPPORTS

FAQS & CASE STUDIES

One Manhattan Square, NY



Product: Hollo-Bolt™
Application: Connecting the grid-shaped Hollow Structural Section (HSS) steel frame.



Lindapter Hollo-Bolts allowed this residential structure to be erected faster than conventional construction techniques.

The spliced HSS connection detail was designed to minimize assembly work in the field. Long sections were fabricated with pre-drilled connection plates welded to one end of each section on all four sides of the square HSS.

When positioned vertically to create a column, the four plates protruded above the height of each HSS, essentially forming a 'socket' for the section above to be located into. Contractors simply inserted Hollo-Bolts into the pre-drilled holes and tightened with a standard torque wrench.

➤ See pages 48 - 65 for Hollo-Bolt.



Benjamin Franklin Bridge, PA



Product: Grate-Fast™ Stainless Steel
Application: Securing open grate flooring for maintenance access.



This suspension bridge connects Philadelphia, PA and Camden, NJ across the Delaware River. Lindapter's Grate-Fast was used to secure open bar grating to maintenance platforms along the length of the bridge.

The Grate-Fast has a cast malleable iron body that provides superior clamping force over the life of the connection and is Lloyds Register approved for resistance to shock and vibration.

Contractors used standard hand tools to secure the grating and this simple installation process resulted in the project being delivered on time and on budget.

➤ See page 70 for Grate-Fast.



Proven connection solutions

Lindapter products are used in multiple industries around the world in an extensive range of applications. The case studies below highlight the wide use of Lindapter connections. To view more project examples please visit www.Lindapter.com

citizenM Hotel Seattle, WA

"It's about 4 months faster to do modular versus conventional, what would typically take about 17 months on a more traditional hotel, can be done in about 13 months when building modular."

Mortenson Construction Project Manager Lauren Boedeker



Product: Hollo-Bolt™

Application: **Connecting modular units during the construction of this hotel in Seattle.**

Polcom was appointed to build 228 modular units for this new hotel in Seattle. The traditional method of connecting the units together by drilling and bolting was not appropriate and hot welding risked damaging the waterproof membrane.

Special steel structural shear plates were designed and added to the modules. Hollo-Bolts were then used to connect through the shear plates to the Hollow Structural Sections (HSS) of each module.

High strength capacity Hollo-Bolts provided a drilling and weld free connection that was quick and easy to install without damaging the waterproof membranes.

➤ See pages 48 - 65 for Hollo-Bolt.



Alexander Hamilton Bridge, NY



Product: Type AF
Application: Structural support connections on a bridge refurbishment.



Widening the bridge deck to introduce two additional traffic lanes required adding cantilever brackets to the main arch span to support the new deck. Structural Engineers specified Lindapter Girder Clamps (approved by NYSDOT) to connect the necessary temporary supports.

Type AF clamps were configured in a customized assembly to suit the flange thickness and angle of each tapered cantilevered bracket. The connection provided the required load capacities and did not require welding or drilling in the field, resulting in a quick and convenient way to temporarily support the cantilevered brackets.

➤ See page 18 for Type AF.



American Helicopter Museum, PA



Product: Lifting Point LP4
Application: Suspending helicopters from the museum ceiling.



Lindapter steel connections were supplied to The American Helicopter Museum for the suspension of an Enstrom F28A Helicopter. Weighing in at over 1500lbs, it is well within the capability of the lifting point, which was fitted with an eye bolt without drilling or welding. Connections have also been specified for arenas and theaters in lighting and sound rigging equipment, as well as in sports facilities to suspend heavy equipment.

Lindapter can design and manufacture customized lifting points for your specific load requirements free of charge. The Type ALP is also available as an off-the-shelf adjustable lifting point that adjusts to suit the beam width, flange thickness and the orientation of the lift.

➤ See page 46 - 47 for Lifting Points.

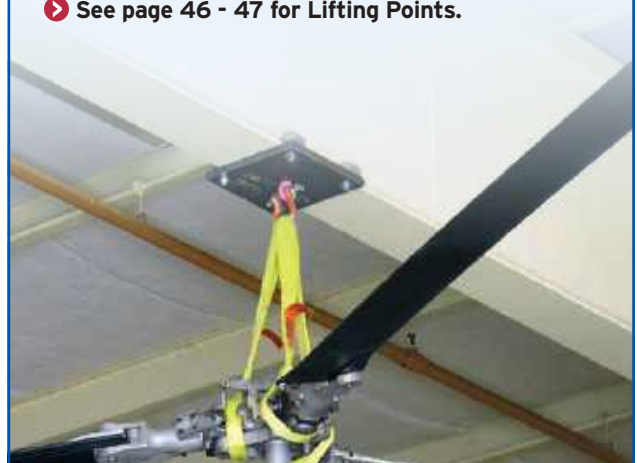

Proven connection solutions

Lindapter products are used in multiple industries around the world in an extensive range of applications. The case studies below highlight the wide use of Lindapter connections. To view more project examples please visit www.Lindapter.com

Wilshire Grand Center, CA



Product: Hollo-Bolt™

Application: Securing primary steel tubes (HSS) which form the canopy of this skyscraper in Los Angeles.

3,000 Hollo-Bolts were used to connect steel tubes which form the curved canopy structure. They were installed from just one side, rapidly achieving discreet splice connections without drilling or welding in the field.

The cost-effective installation did not require specialist equipment or labor and reduced the amount of work at height in comparison to welding or through-bolting.

The design eradicated the possibility of tube deformation that can be associated with through-bolting if the bolts are over-tightened. The result was aesthetically pleasing, clean and discreet connections which complement the architecturally exposed structural steel design.

➔ See pages 48 - 65 for Hollo-Bolt.



Allegiant Stadium, NV

© Jason O'Rear



Product: Type AAF
Application: Connecting a 275 foot electronic media mesh screen to the stadium's exterior.



To secure the huge video screen to the front of this \$1.8 billion structure, contractors used 4,200 of Lindapter's high slip resistance Type AAF Girder Clamps to connect the brackets and plates to the structural columns.

Type AAF Girder Clamps provided a drilling and weld free connection that was quick and easy to install whilst working at height. Type AAF self-adjusts to suit the flange thickness which allows assemblies to be positioned close to where they are needed before final adjustments are made. The clamps can then be fully tightened using a calibrated torque wrench. Before the screen was installed the clamps were painted black to match the stadium's color scheme.

➔ See page 12 for Type AAF.



Tobin Memorial Bridge, MA

© mansmart via Flickr (CC BY-SA 2.0)



Product: Hollo-Bolt™
Application: Connecting checker plate walkway covers on the safety curbs.



Due to limited access to the 11,800 ft long bridge structure, a bolted connection with one-sided access was required for the repair of the safety curbs on the walkway. Over 50,000 Hollo-Bolts were specified due to their high strength capacity and ability to be installed from one side of the bridge steel.

The checker plate covers were formed off-field into "S" shapes and then installed onto the safety curbs using 1/2" stainless steel Hollo-Bolts with hexagonal head on the vertical sections. 5/16" stainless steel Hollo-Bolts with countersunk head were then used on the horizontal sections to reduce trip hazards for bridge maintenance personnel and contribute to a safer walkway.

➔ See pages 48 - 65 for Hollo-Bolt.



GIRDER CLAMPS

LIFTING POINTS

HOLLO-BOLT

FLOOR CONNECTIONS

PIPE SUPPORTS

FAQS & CASE STUDIES

Proven connection solutions

Lindapter products are used in multiple industries around the world in an extensive range of applications. The case studies below highlight the wide use of Lindapter connections. To view more project examples please visit www.Lindapter.com

Blue Oval City, TN

© Ford Newsroom



Product: Type AAF

Application: Securing seismic bracing cables to the primary steel of the battery manufacturing facility.

As located in Seismic Design Category D, the engineer required a method to restrain pipe racks and suspended ceiling, however, Ford stipulated no permanent connections to future-proof manufacturing reconfiguration. Lindapter proposed to attach the 1/2" diameter 6x19 steel wire bracing system to the primary steel using high strength and adjustable Type AAF clamps. This enabled a fast installation and overcame the additional challenge of connecting beams varying from W14x90 to W14x283.

Lindapter's technical solution met the client's key requirement of a code-compliant, seismic resistant connection that can be removed for future reconfiguration of this world-class manufacturing facility.

➔ See page 12 for Type AAF.



Citi Field, NY



© Samsung Newsroom U.S.

Product: Type AAF
Application: Connecting the largest video display board in Major League Baseball.



Samsung previously worked with Lindapter on other successful projects and experienced the time-saving benefits, therefore confidently specified girder clamps again. This design included angle brackets on the display frame clamped to the existing W10 steel columns.

The connection solution enabled a fast and safe installation, and also avoided difficult field drilling or welding at height. Lindapter's Type AAF clamps in a 2-bolt configuration provided the necessary slip resistance while the self-adjusting feature proved to be extremely useful for the installer as they used one product type throughout despite different flange thicknesses of the columns, further reducing installation time and cost.

➤ See page 12 for Type AAF.



Zeta South Bronx School, NY



© 2023 Taylor Photo

Product: Type AAF & Type CF
Application: Installation of a rooftop play area enclosure.



YAS previously benefitted from Lindapter's technical support service and once again asked for a connection detail to connect wire mesh panels to the steel frame of the enclosure.

The use of both Type AAF and Type CF clamps enabled connections to be easily achieved on vertical columns and horizontal sections. The clamps provide substantial resistance to slip and tensile loading, plus a high level of corrosion protection.

The no drilling and no welding connection was quick and easy to install, with the additional convenience of being able to adjust the clamps to locate the wire mesh panels into their final positions before tightening.

➤ See page 12 for Type AAF & page 24 for Type CF.



Notes

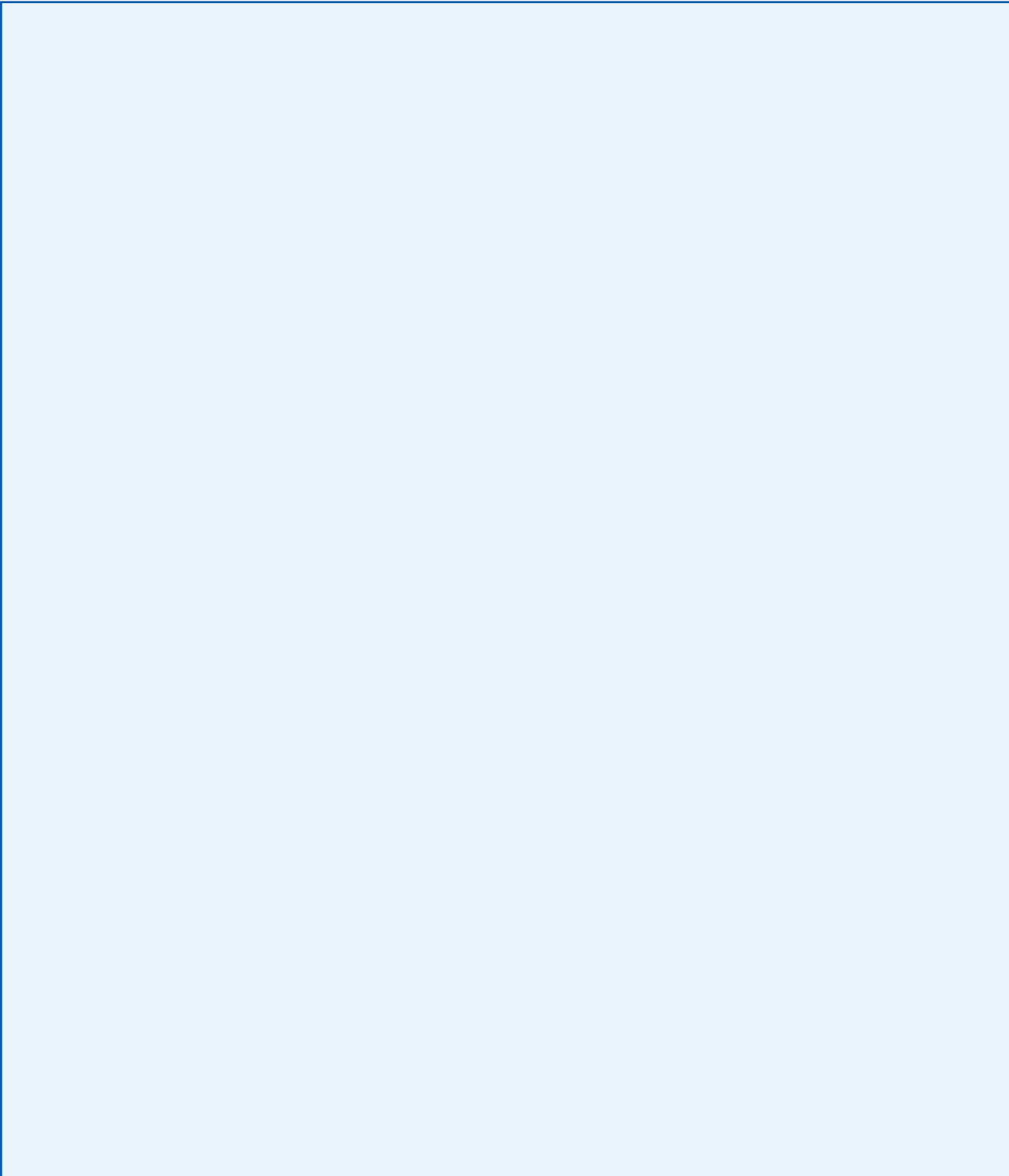

Notes

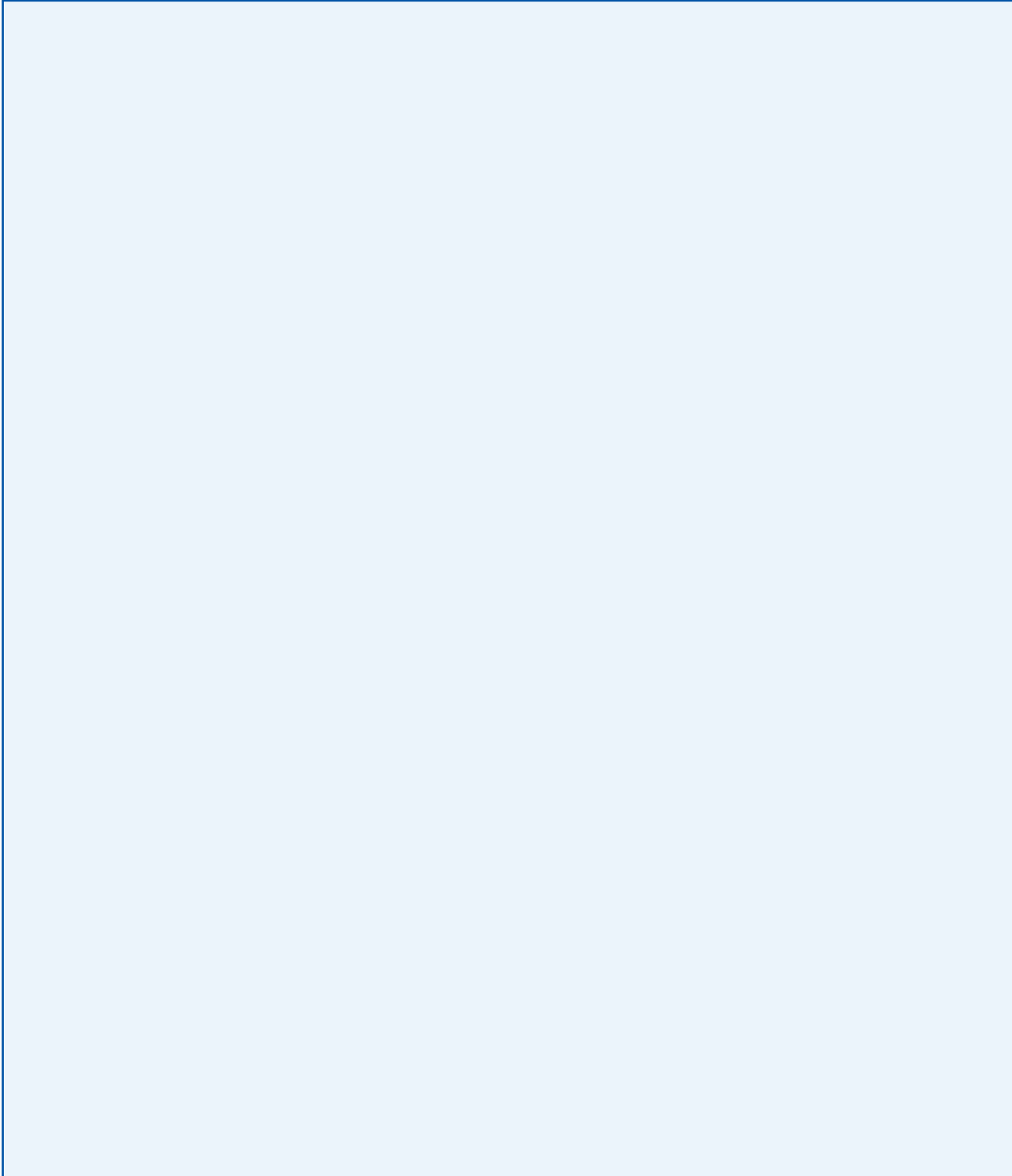

Passionate about safety

For over 90 years, Lindapter has manufactured to the highest standards, earning a multitude of independent approvals and a reputation synonymous with safety and reliability. Current accreditations are detailed below.

Quality, Environment and Traceability

Accredited to **ISO 9001** since 1986, Lindapter strictly enforces a quality management system that includes rigorous product testing to ensure consistently high manufacturing standards. As part of Lindapter's ISO 9001 quality management system and in compliance with the Construction Products Regulation, Lindapter operates a comprehensive Factory Production Control system that ensures traceability of all Lindapter products throughout the manufacturing process.

The company also operates an **ISO 14001** certified environmental management system, constantly monitoring and improving aspects of the business that may impact on the environment, such as the use of natural resources as well as handling and treatment of waste and energy consumption.



Independent Product Approvals & Associations

These approvals reinforce Lindapter's extensive in-house testing procedures. Products are tested so that Engineers and Contractors can be confident Lindapter products will perform as detailed in this catalog.



ICC-ES
North America's leading evaluation service has approved multiple Lindapter products to be compliant with the International Building Code. Girder Clamps (Types AF and AAF) and Hollo-Bolts are ICC-ES approved to resist wind and seismic loads.



CE Mark
CE Marking provides additional assurance that a product complies with the Construction Product Regulation and will perform as stated in the corresponding Declaration of Performance (DoP).



UKCA Mark
This demonstrates compliance with the Construction Products Regulation in Great Britain. Independently verified product specification data, including Characteristic Resistances for designing connections to Eurocode 3 are published in Declaration of Conformity (DoC) documents.



VdS Schadenverhütung GmbH
VdS is a leading independent testing institution in Germany for products used in fire protection applications.



Factory Mutual
This American insurance organization offers an approval that is recognized by the fire protection industry worldwide.



Lloyd's Register Type Approval
Lloyd's Register Type Approved products have been subjected to tensile, frictional, vibration and shock tests, witnessed and verified by Lloyd's Register.



TÜV Nord
TÜV is the certifying authority for safety, quality and environmental protection in Germany.

Associations

Lindapter is a member of the **American Institute of Steel Construction (AISC)**, **Canadian Institute of Steel Construction (CISC)**, **British Constructional Steelwork Association (BCSA)**, **The Steel Construction Institute (SCI)**, **The National Council of Structural Engineers Association (NCSEA)**, **Steel Tube Institute**, **Modular Building Institute (MBI)** and many more. See the full list at www.Lindapter.com



Live Webinars

We are pleased to offer live webinars **free of charge** to Structural Engineers, Consulting Engineers, Graduate Engineers and Specifiers. More information is below, to view our webinar schedule and to register visit www.Lindapter.com

Designing Steel Connections Without Drilling or Welding

Gain an update on the latest ICC-ES approved steel-to-steel connections and an insight to the technical and practical advantages of specifying innovative clamping systems. Our experienced presenter will introduce a range of faster, cost-effective alternatives to conventional bolted and welded connections at a date and time to suit you.

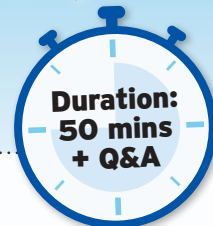

Introduction to Lindapter

- Our history which began in 1934.
- Market sectors and industries we supply.
- Global brands we have worked with.

Conventional Connection Methods vs Lindapter Method

Overview of welding and drilling and bolting versus Lindapter clamping systems.

Innovative Solutions

- Girder Clamps for connecting steel sections.
- Floor connections for steel plate and open bar grating.
- Hollo-Bolt expansion bolts for connecting to HSS.

Typical Applications, Installation and Case Studies

See a wide selection of typical assemblies that are possible with Lindapter products and find out how other customers have used them to solve problems in real case study examples. Video animations are also used to demonstrate the simplicity of installation.

Technical Support (Free Connection Detailing)

Learn about our industry leading Technical Support services, including FREE connection detailing, site visits and contractor product installation training.

Research & Development (Engineered Solutions)

Do you have a unique connection problem? Our R&D facility can work with you to develop custom products and solutions.

Q&A Session

Submit your questions during the webinar and our experienced presenter will answer as many as possible at the end during a live 10 minute Q&A session.



To view our webinar schedule and to register free of charge visit www.Lindapter.com

Disclaimer
Lindapter International supplies components in good faith, on the assumption that customers fully understand the loadings, safety factors and physical parameters of the products involved. Customers or users who are unaware or unsure of any details should refer to Lindapter International before use. Responsibility for loss, damage, or other consequences of misuse cannot be accepted. Lindapter makes every effort to ensure that technical specifications and other product descriptions are correct. 'Specification' shall mean the specification (relating to the use of the materials) set out in the quotation given by the Seller to the Buyer. Responsibility for errors or omissions cannot be accepted. All dimensions stated are subject to production tolerances - if in doubt please check with Lindapter. In the interests of improving the quality and performance of Lindapter products, we reserve the right to make specification changes without prior notice.

© Lindapter International 2025
LINDAPTER is a registered trademark. Lindapter may also have trademark rights in other terms used herein.



Lindapter[®]

Call:

866 566-2658 (BOLT)

General Inquiries:

inquiries@Lindapter.com

Technical Inquiries:

support@Lindapter.com

Website:

www.Lindapter.com

Follow us on [LinkedIn](#)