

Efficient and Integrated Design of Modern Steel Highway Bridges

Francesco M Russo, PhD, PE
Russo Structural Services

Frank.Russo@RussoStructural.com

Presentation Outline

- Part 1 – Fundamental concepts for steel bridge layout
- Part 2 – Standard Plans review
 - An overview of the NSBA Standard Plans

You Want to Design a Steel Bridge? What is required?

- Span arrangement
- Beam spacing and overhang
- Bracing type and spacing
- Flange and web sizing
- Stiffeners, splices, shear connectors, etc.
- Other new and “fun” checks
 - Wind on the erected steel
 - LRFD 10th edition stability requirements

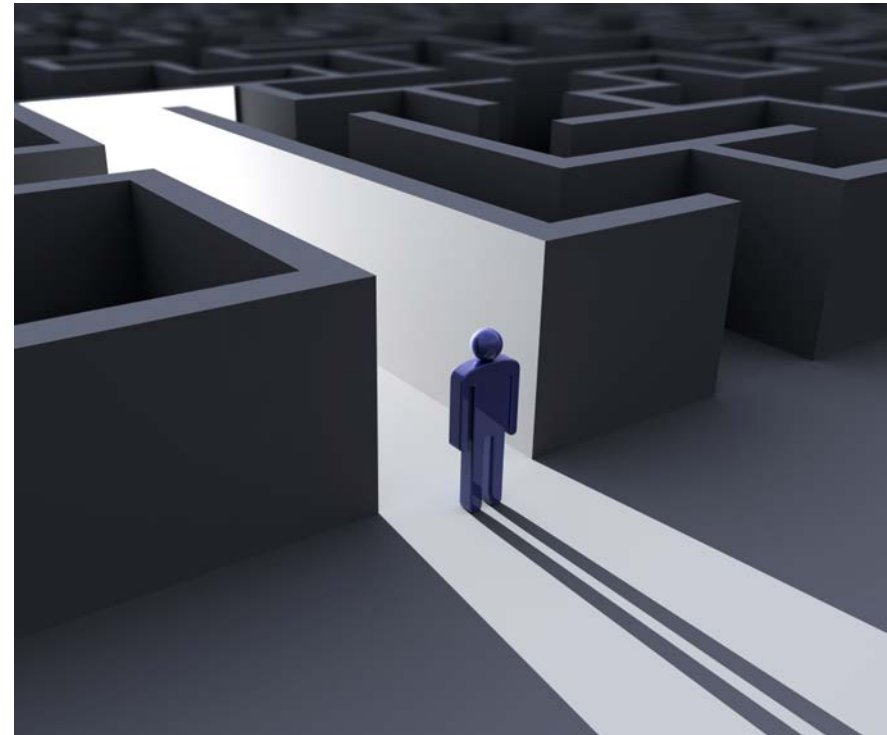

What is Bridge Design ?

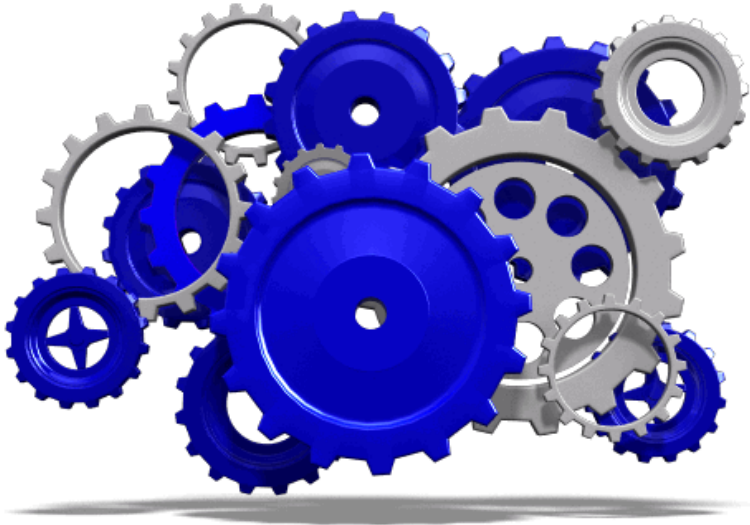

Bridge design is a unique combination of

- ***Shall / Must***
 - AASHTO
- ***Should***
 - AASHTO Commentary
- ***It would be good if ...***
 - NSBA Collaboration Documents
- ***I wish you would ...***
 - other guidance, fabricator and erector preferences
- ***Don't you dare ...***
 - avoid this at all costs

There are many good answers, my goal is help you avoid the bad ones

Let's Begin at the End

<https://www.aisc.org/nsba>



aisc CERTIFICATION MEMBERSHIP MODERN STEEL BRIDGES ARCHITECTURE CONFERENCE

WHY STEEL BRIDGES? DESIGN AND ESTIMATING EDUCATION GET INVOLVED AWARDS EMERGENCY SOLUTIONS

NATIONAL STEEL BRIDGE ALLIANCE

FIND A BRIDGE FABRICATOR
AASHTO/NSBA COLLABORATION
ADVOCACY
A CENTURY OF AMERICAN STEEL BRIDGES
ABOUT NSBA

Uncoated Weathering Steel Reference Guide

If speed is what you need, uncoated weathering steel is the best choice! UWS is the most applied coating and no time spent literally watching paint dry. NSBA's new Uncoated Weathering Steel Reference Guide is your go-to resource for using UWS in a variety of bridges in a diverse mix of environments.

LEARN MORE

AISC/NSBA Standard Plans for Steel Bridges

The AISC/NSBA Standard Plans for Steel Bridges simplify and speed up the bridge design process for steel plate girder bridges. These standard plans provide numerous straight steel I-girder bridge plans for a suite of various span arrangements and lengths—optimized for cost-efficiency throughout design, material selection, fabrication, and construction. They cover one-, two-, three-, and four-span configurations with span lengths ranging from 80 ft to 300 ft, and girder spacings of 8, 10, 12, and 14 ft.

Bridge Layout and Planning

Span Layout for Continuous Spans

- For multi-span bridges, continuous spans are generally preferred
- A balanced span arrangement is also preferred
 - Peak positive and negative moments nearly equal in all spans



Balanced Span Arrangement

- End spans 75% - 82% of center span

It would be good if ...



Depth to Span Ratio Bare Girder (LRFD 2.5.2.6.3)

- Suggested minimum depth of I-beam portion only

$0.033L$ ($L/30$)

$0.027L$ ($80\% * L/30$)

L = Total span length

Simple Spans

Continuous Spans

Must or should
depending on
your owner

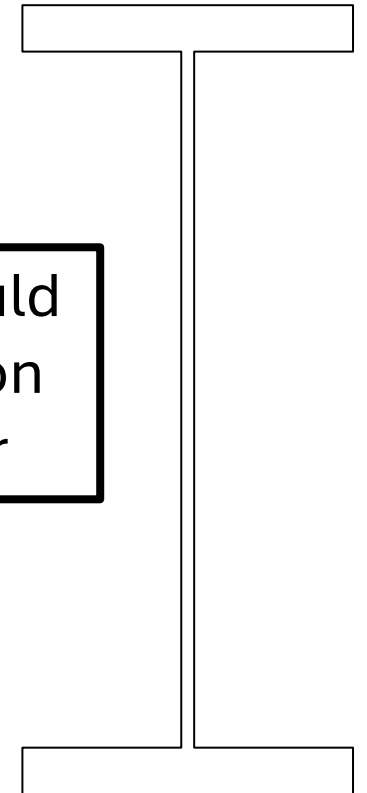

Steel-Girder Bridge Components – Bracing

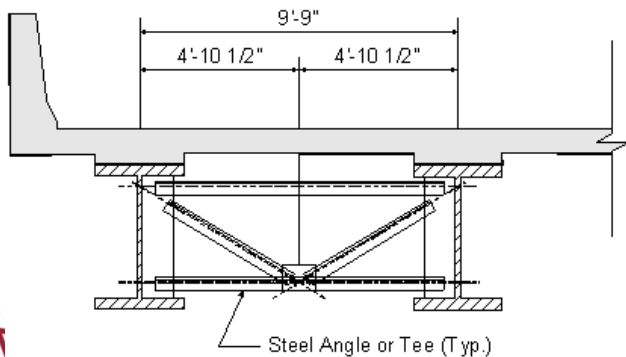

Cross-frames

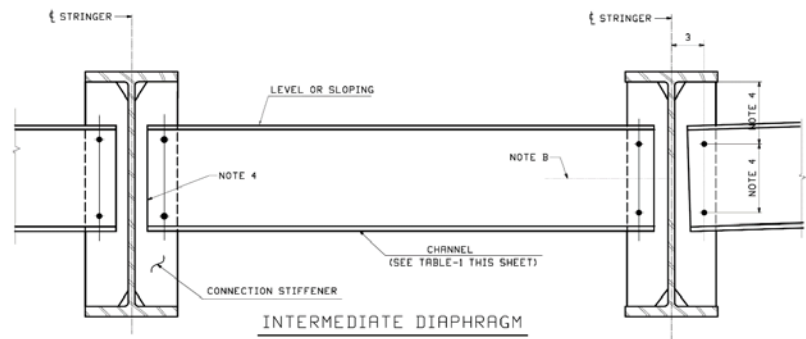

Diaphragms

So Where Are We ?

- We have a “good design”
 - Practical and simple layout
 - We chose a rational layout of spans
 - Beam spacing and overhangs make sense
 - We chose a reasonable girder depth
 - Practical bracing layout was provided
 - **All of this can be designed with a line girder, LRFD SIMON**
- Are we done?



AASHTO Wind Loads During Construction

Strength Loads

Service

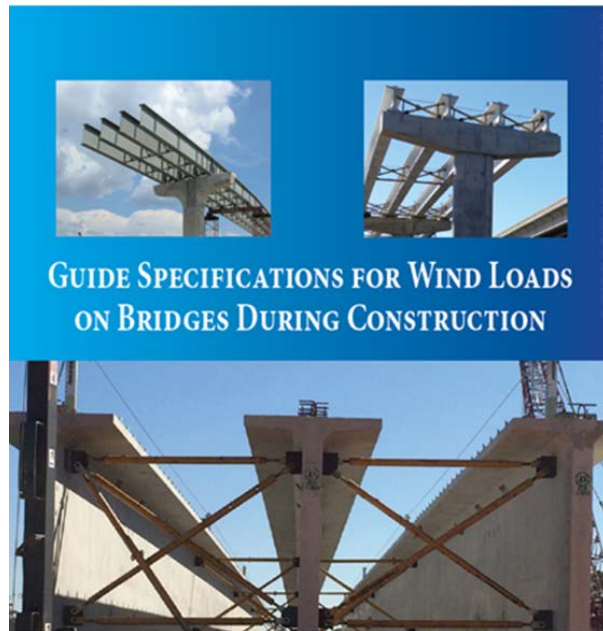

AMERICAN ASSOCIATION
OF STATE HIGHWAY AND
TRANSPORTATION OFFICIALS
AASHTO

1ST EDITION • 2017

AASHTO Publication Code: GSWE-1
ISBN: 978-1-5613-631-4



Wind Load Behavior – Single Spans

- Wind loads applied to the open framing cause lateral deflection, and flange lateral bending stresses
- These must be checked as part of girder strength / stress analysis
- Deflections “might be” a concern

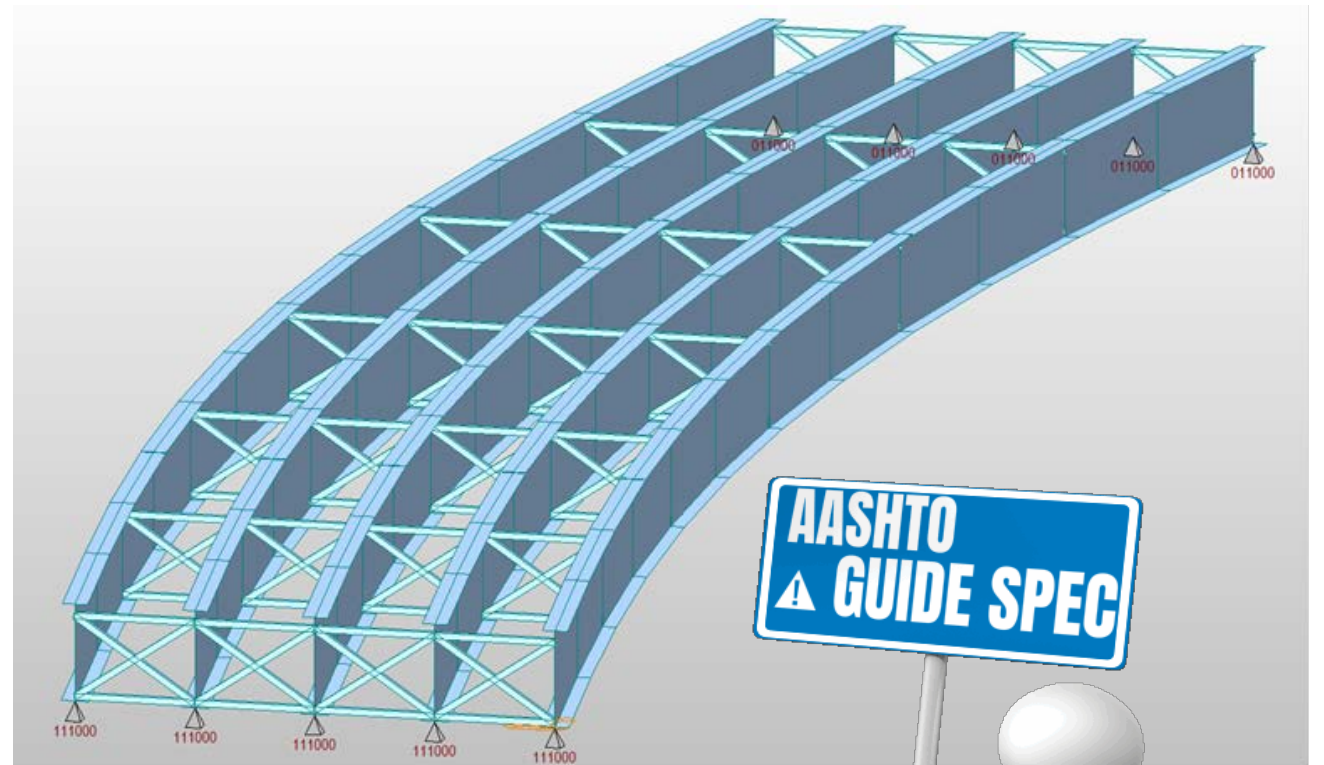

Lateral Behavior of Continuous Spans

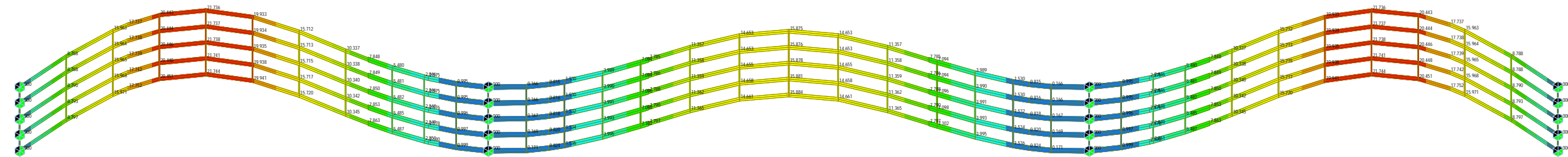

- Deflection and stresses in continuous spans are dependent on many factors.
- A grillage or even a single line girder should be used to estimate the deflections and flange lateral bending stresses.

New AASHTO 10th Edition Stability Bracing Requirements, 6.7.4.2.2

Minimum Stiffness Requirements

$$(\beta_T)_{req} = \frac{2.4L}{\phi_{sb} n E I_{yeff}} \left(\frac{M_u}{C_b} \right)^2$$

- L = Span length
- n = Num of braces in the span, excluding end braces
- M_u = factored deck casting moment

• I_{yeff}

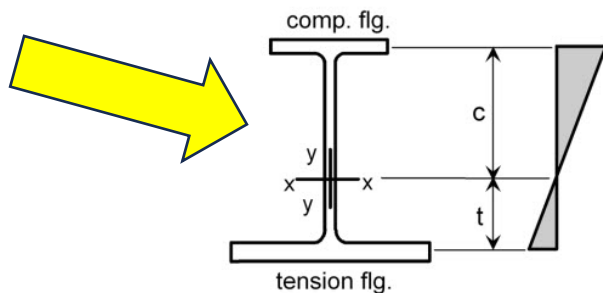

Minimum Strength Requirements

$$M_{br} = \frac{2.4L}{n E I_{yeff}} \left(\frac{M_u}{C_b} \right)^2 \left(\frac{L_b}{500 h_o} \right)$$

- L_b = brace spacing
- h_o = distance between flange centroids

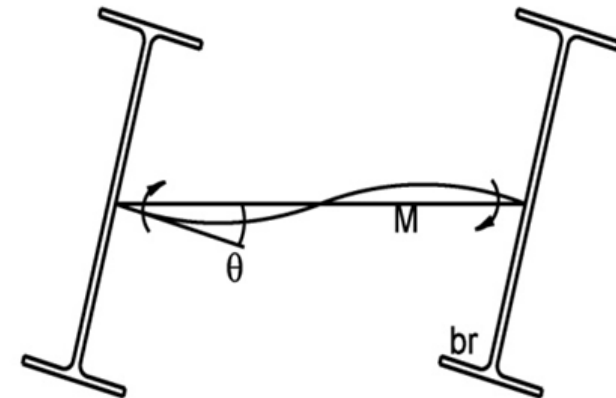

Standard Design and Plans for Modern Steel Highway Bridges

What is this project about? What are the deliverables?

Project Team



- Russo Structural Services
 - Prime consultant
 - Lead Designer



- Genesis Structures
 - Constructability advisors
 - CAD / drawing preparation

M.A. Grubb
& Associates, LLC

- M A Grubb & Associates
 - Independent design review and quality control
 - AASHTO code compliance



Fabricator Outreach and Preliminary Studies

What important questions were asked and answered to develop the standards?

Fabricator Outreach

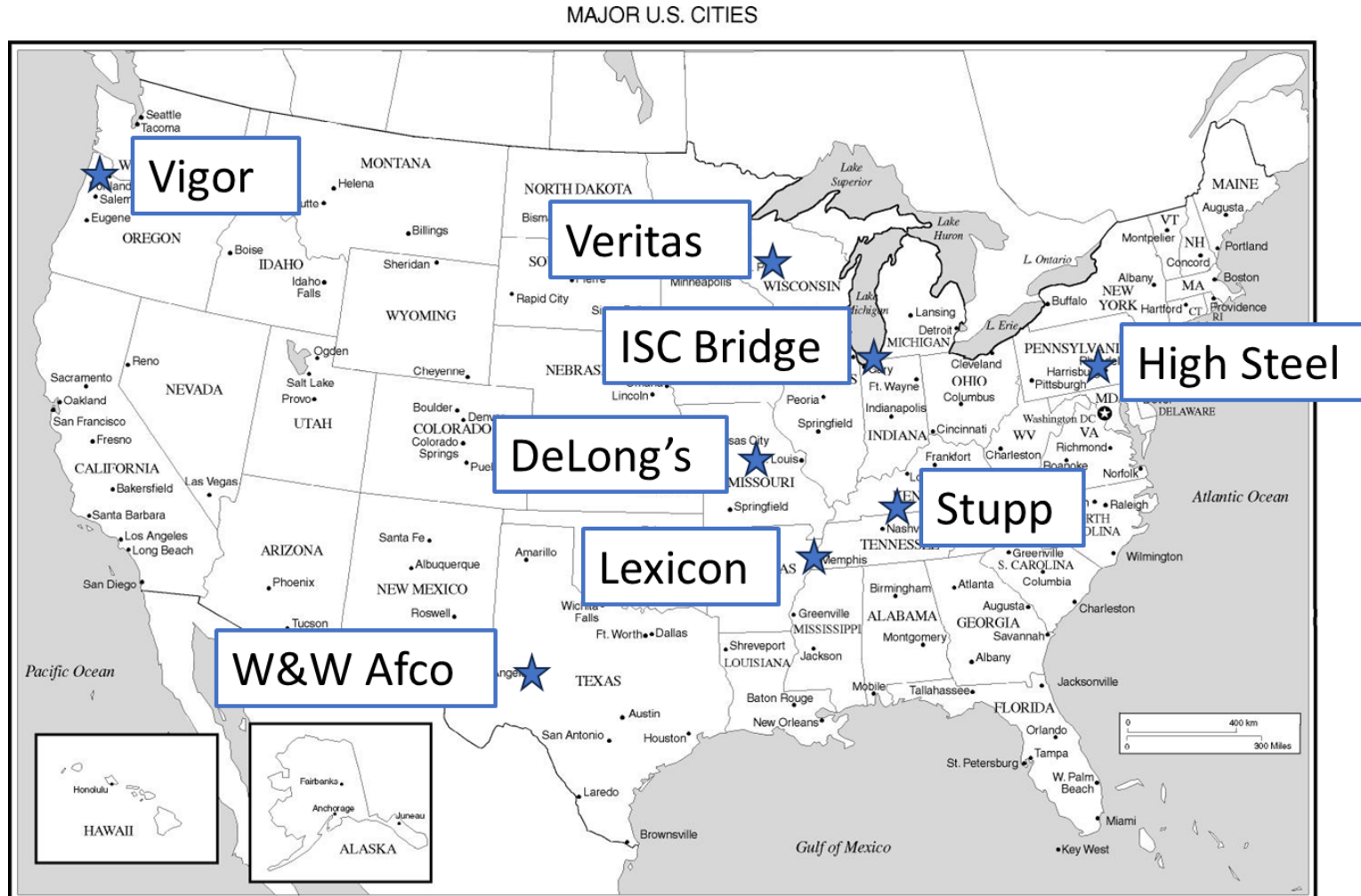

Q1 – Cost-effective And Optimal Mill Plate Sizes For Webs And Flanges Of I-girders.

- Flanges in any width are acceptable
 - Use as few thicknesses as possible
- Common slab availability 48 – 140 in. Wide
 - More common availability 72 – 120 in. Wide
 - Most cost competition in 72 – 96 in. Wide
- Flanges in 1/4” thickness increments, 1” minimum
- Webs in 1/8” increments, 1/2” minimum
- Flange thickness 3” maximum preferred (or switch to HPS 70W)

Q2 – Cost Effectiveness Of HPS 70W Vs Gr 50W

- Use gr 50W until about 3” thick
- An “over 3” flange” has a cost premium even in gr 50W so HPS 70W can be used to offset this premium and save weight
- Go wider to stay under 3” when possible
- Various cost data points HPS 70W vs gr 50W (fall 2021 – spring 2022)
 - \$20 / cwt
 - From 50-50W (\$5 / cwt) from 50W to HPS 70W (\$25 / cwt)
 - \$14 / cwt
 - \$20 / cwt for ≤ 2 ” and \$34 / cwt over 2”

Q3 – Maximum Number Of Unique Plate Sizes

- 2 webs and 6 unique flanges seem reasonable
- The fewer the better, and at least 10T minimum for any thickness
- NSBA CJP tables are dated but for designers are still a good starting point
- Fabricators have their own weld vs plate cost savings approach used internally

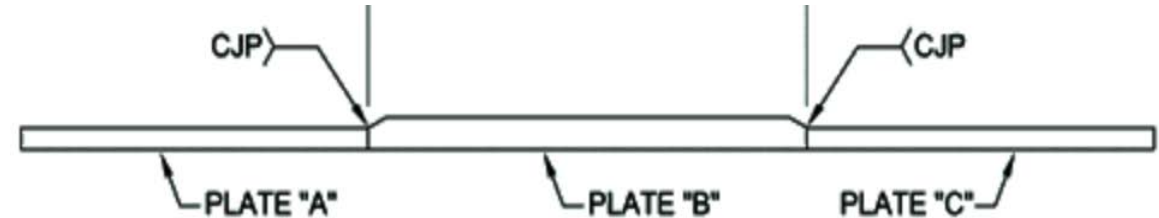

Multiply weight savings/inch × flange width (length of butt weld)

Thinner Plate at Splice (inches)	Thicker Plate at Splice (inches)						
	1.0	1.5	2.0	2.5	3.0	3.5	4.0
1.0	70	70	70	—	—	—	—
1.5	—	80	80	80	80	—	—
2.0	—	—	90	90	90	70	70
2.5	—	—	—	100	100	80	80
3.0	—	—	—	—	110	90	90
3.5	—	—	—	—	—	110	110
4.0	—	—	—	—	—	—	130

Notes:

- Source: compiled from various Fabricators, November 2001.

Q4 – Cost Effective Slab Widths And Considerations For Miscellaneous Parts, Studs, Etc.

- Slabs 72 – 120” are most common
- Order in “required sum of plate widths” plus 4 – 6 in. For trimming and burn lines
- Web plate ordered for height + camber + 4-6 in.
- Use the same thickness plate for transverse stiffeners for the whole bridge if possible. Repeat a common plate for bearing stiffeners
- Advantageous if stiffeners can be cut from a slab used for webs or flanges but not necessary
- Parts plates commonly come from service centers, 8’ x 20’ x “t” in 1/4” thickness increments

Q5 – Field Section Lengths

- Length
 - 120 ft – no problems
 - 130 – 140 generally not a problem
 - Some fabricators have access challenges even getting out of their own plants and on the roads > 150 ft
 - Decision – maximum field section 140 ft long
- Depth
 - Girders under 10 ft deep – no problem for anyone
 - Girders under 12 ft deep definitely preferred
 - Decision – maximum web depth was kept to 11 ft
- Weight
 - Decision – 50T field section limit
 - Influences the longest spans only and drove the decision to switch to HPS 70W in some cases

Choice of Splice Location 2-Span Bridges

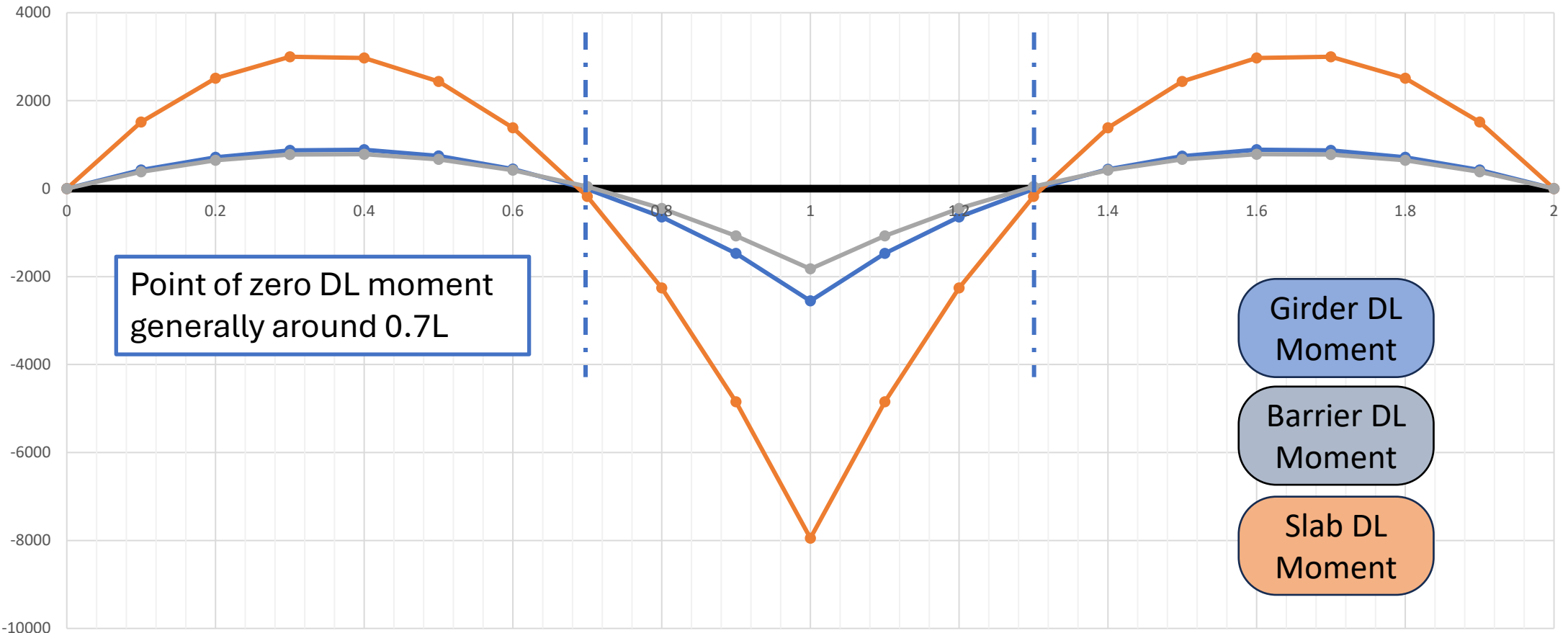

Choice of Splice Location 3-Span Bridges

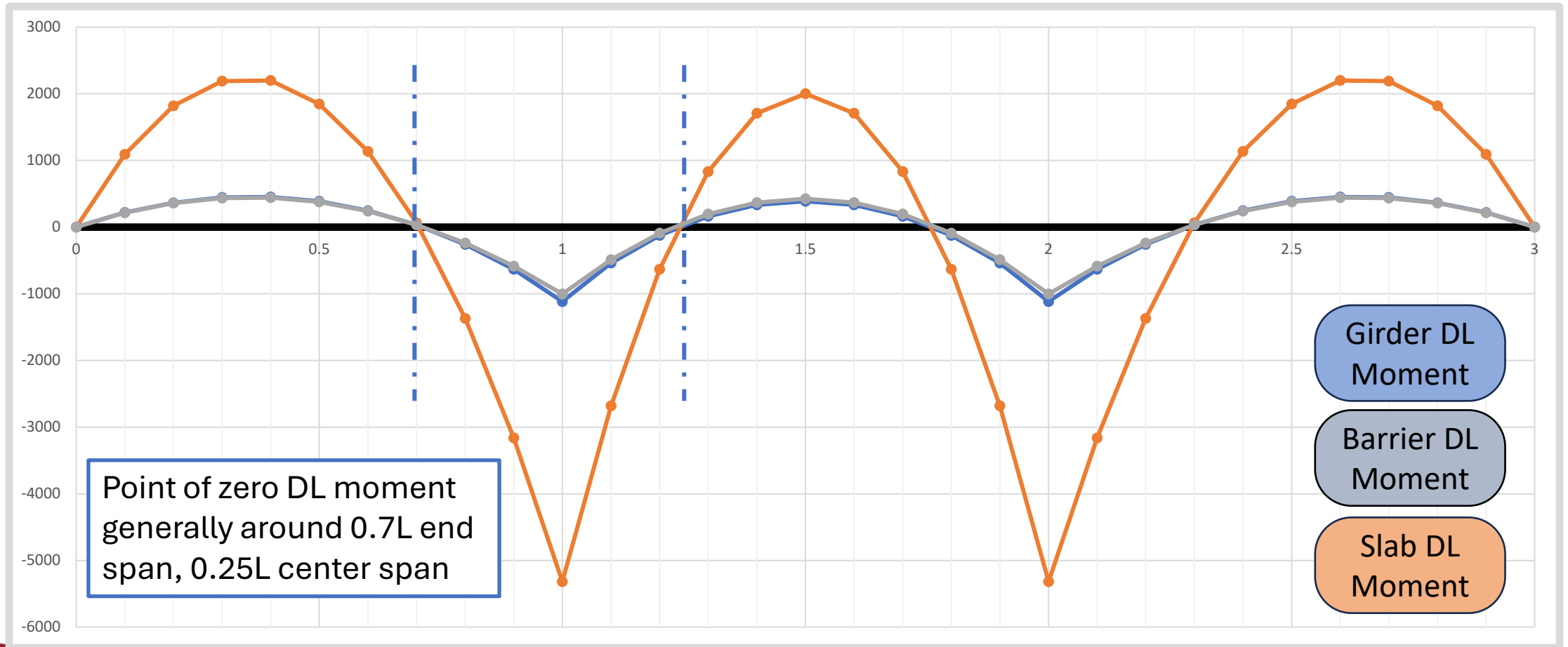

Choice of Splice Location 3-Span Bridges

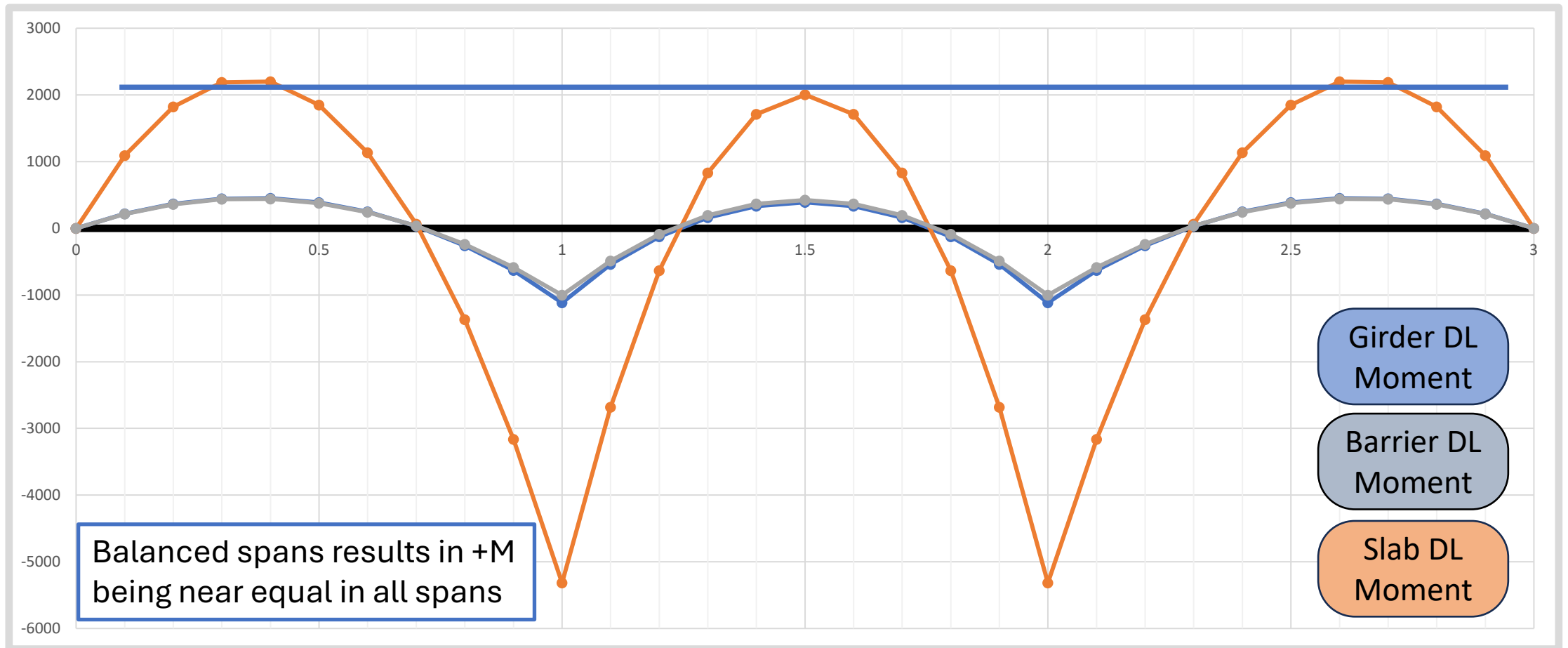

Choice of Splice Location 4-Span Bridges

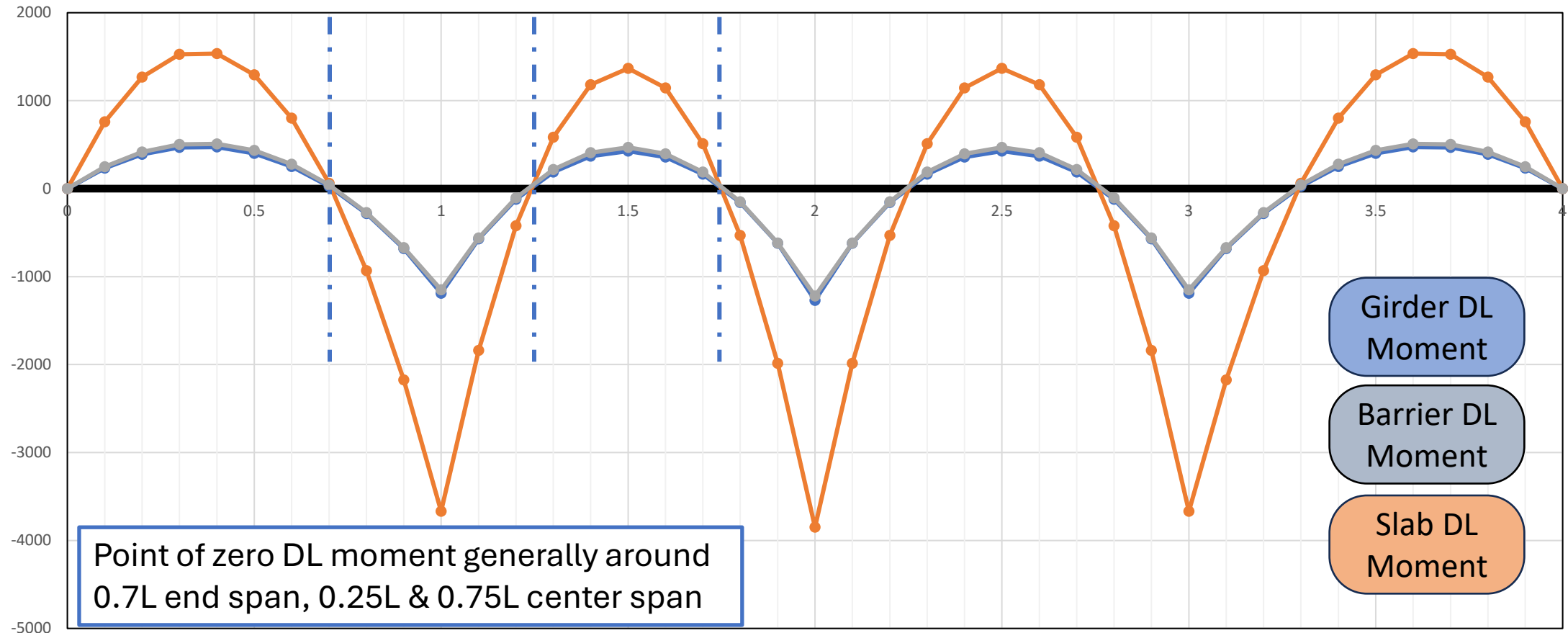

Choice of Splice Location 4-Span Bridges

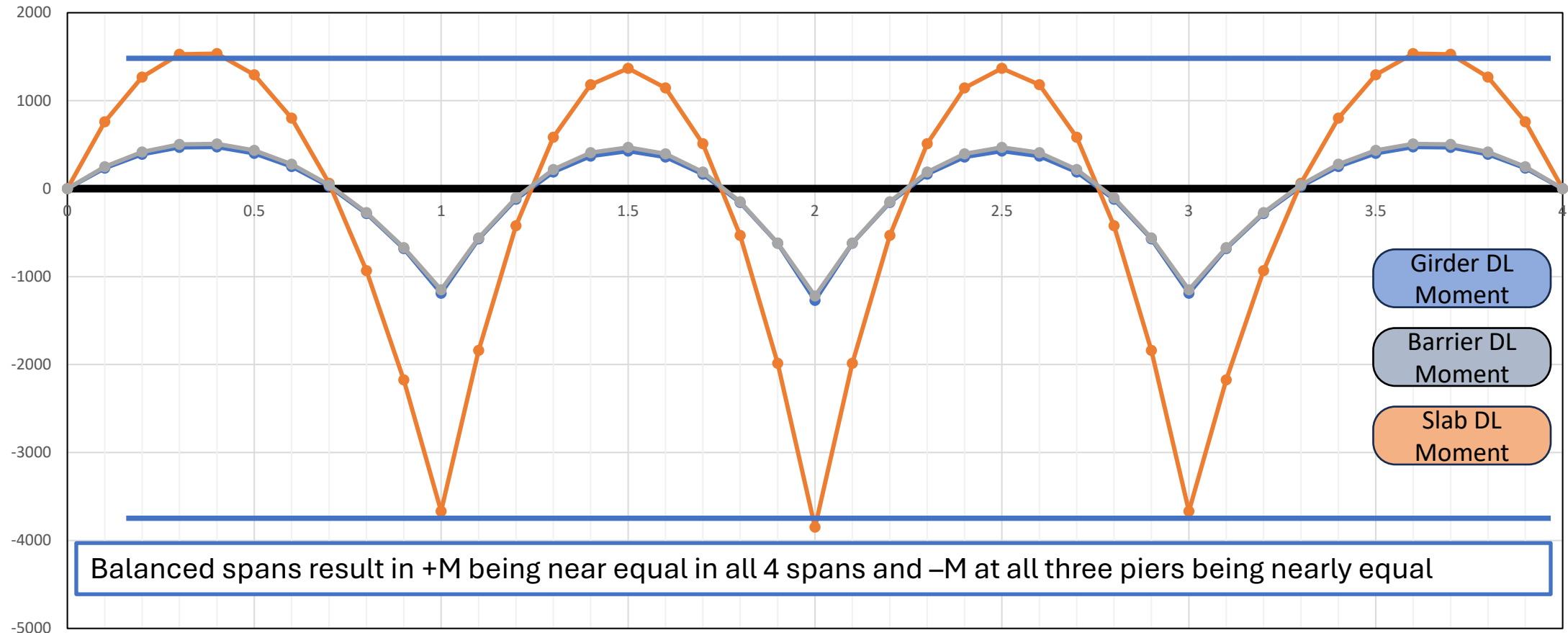

Q6 – Cost Effective Diaphragms And Cross-frames



Q6 – Cost Effective Diaphragms And Cross-frames

- Angles preferred to WT
- Weld to a gusset plate and bolt to stiffeners is preferred
- Avoid back-to-back members
- Do not wrap welds front to back face
- Do not over-dimension – more chances for errors
- Galvanizing is preferred and common for frames

When To Use An X-frame, $S/D \approx 1.5$ Max.

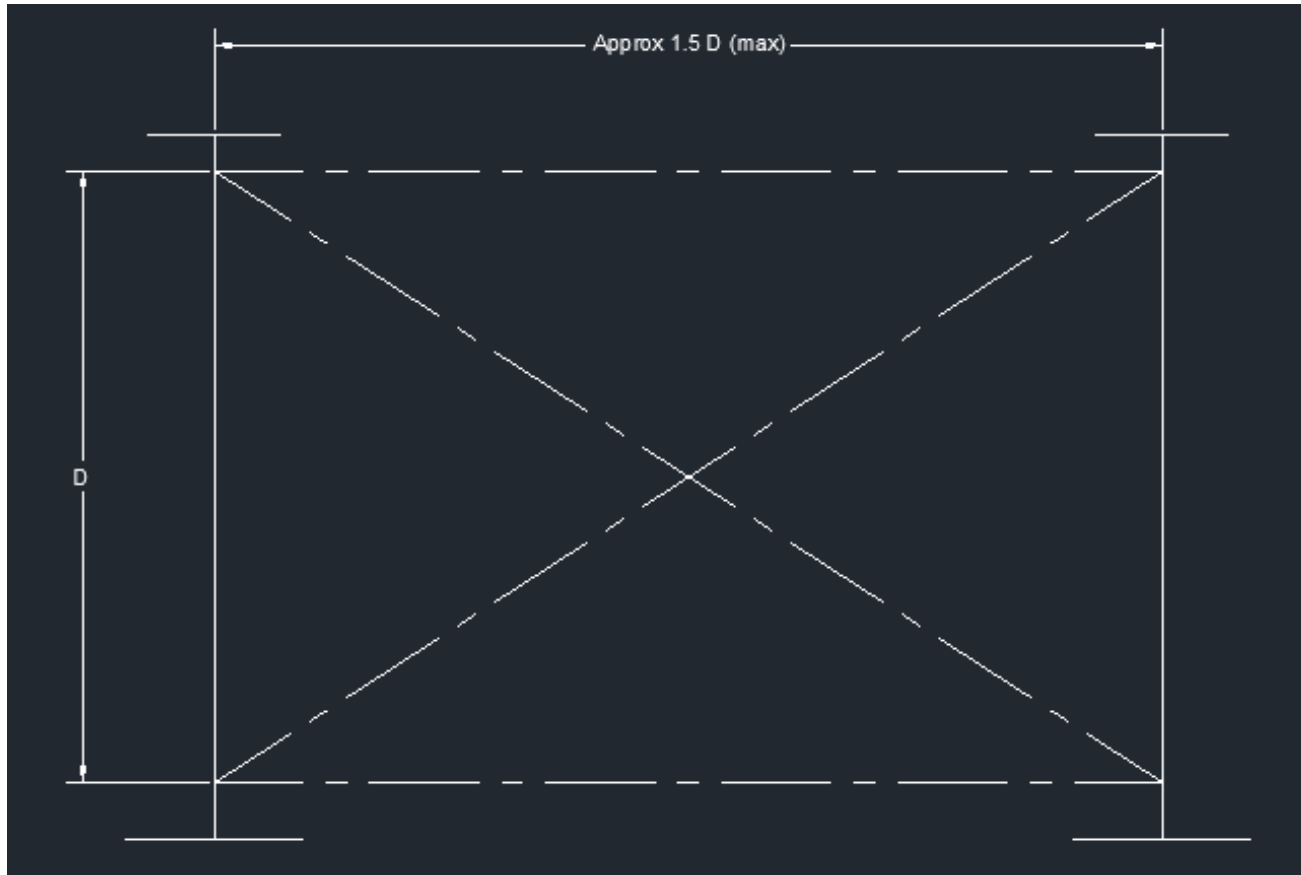

When To Use A K-frame, $S/D \approx 1.5 - 3.5$

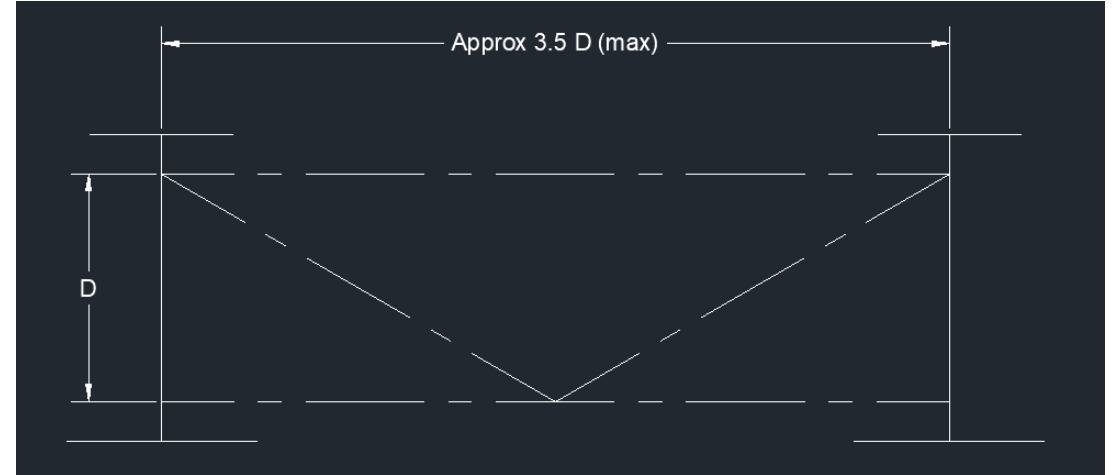
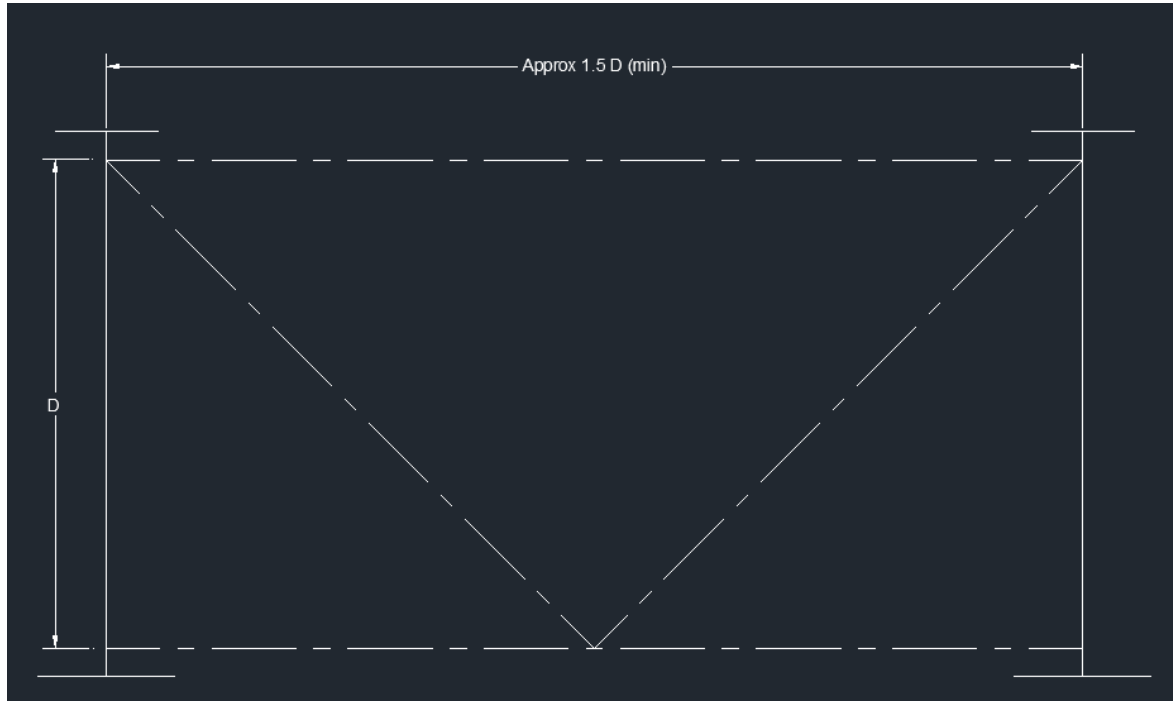

When To Use A Solid Diaphragm, $S/D > \approx 3.5$

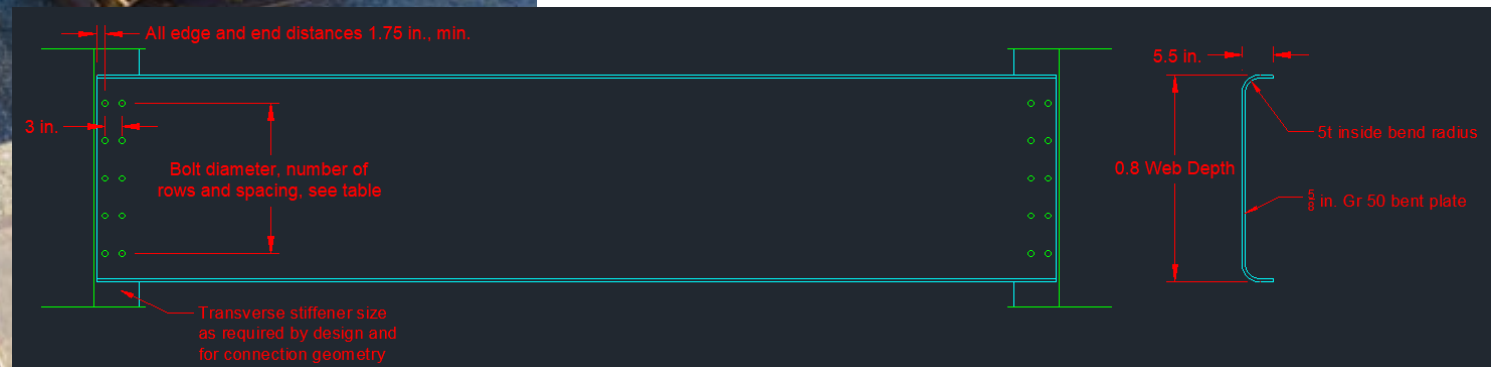

Q7 – Corrosion Protection Considerations

- Weathering is preferred over all other options
- Large girders can be difficult to paint and may not fit in blast bays
- Metallizing is time consuming, 4-5x slower than painting. Owners should be aware
- Not all fabricators can metallize in-house and have to send it out
- Galvanizing is good for small members, has size limits that limit the use on main members. About 75 ft long and 6 ft tall was suggested as a limit

Presentation of Selected Portions of the Standards

Standard Designs for Straight I-Girder Bridges

- Single Span Bridges (8, 10, 12, 14 ft spacing):

- 80 – 300 ft (10 ft increments)
- Cross-frame & Diaphragm Details
- Lateral Bracing Details
- Bolted Field Splices
- Deck Details
- Link Slab Details

- 39 sheets



Standard Plans for Steel Bridges

Single Span Bridges and
Multi-span Bridges
with Link Slabs



Smarter.
Stronger.
Steel.

Standard Designs for Straight I-Girder Bridges

- 2-Span Continuous Bridges (8, 10, 12, 14 ft spacing):

- Equal Spans, 100 – 250 ft (15 ft increments)
- Deck Pouring Sequence
- Cross-frame & Diaphragm Details
- Lateral Bracing Details
- Bolted Field Splices
- Deck Details

- **28 sheets**



Standard Plans for Steel Bridges

Two-span
Continuous
Span Bridges



Standard Designs for Straight I-Girder Bridges

- 3-Span Continuous Bridges (8, 10, 12, 14 ft spacing):

- Center spans, 150 – 300 ft (15 ft increments)
- End span = 78% of center span
- Deck Pouring Sequence
- Cross-frame & Diaphragm Details
- Bolted Field Splices
- Deck Details

- **33 sheets**

Span, ft. End-Int.-End
117-150-117
129-165-129
141-180-141
153-195-153
164-210-164
176-225-176
188-240-188
199-255-199
211-270-211
223-285-223
234-300-234



Standard Plans for Steel Bridges

Three-span
Continuous
Span Bridges



Standard Designs for Straight I-Girder Bridges

- 4-Span Continuous Bridges (8, 10, 12, 14 ft spacing):

- Two center spans = 150 – 300 ft (15 ft increments)
- End span = 78% of center span
- Deck Pouring Sequence
- Cross-frame & Diaphragm Details
- Bolted Field Splices
- Deck Details

- **33 sheets**

Span, ft. End-Interior
117-150
129-165
141-180
153-195
164-210
176-225
188-240
199-255
211-270
223-285
234-300



Standard Plans for Steel Bridges

Four-span
Continuous
Span Bridges



Final Cross-Sections

8 ft beam spacing

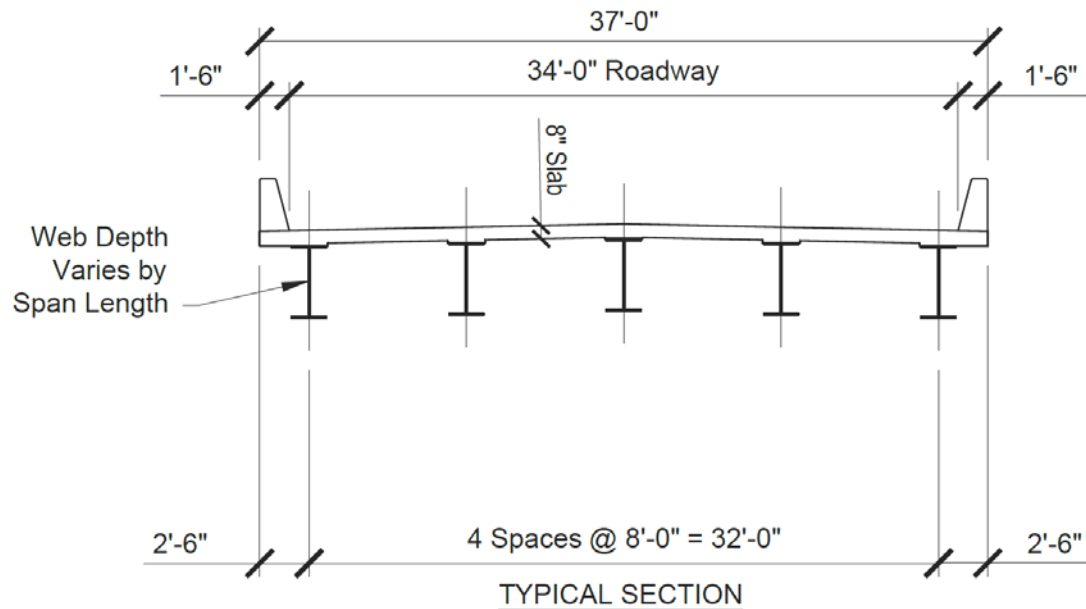

0.31S

10 ft beam spacing

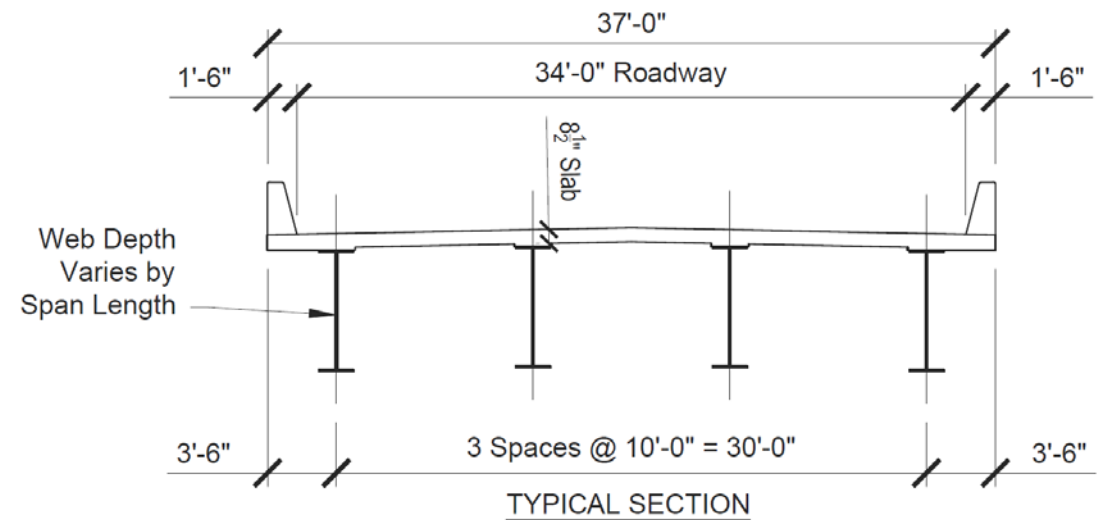

0.35S

Final Cross-Sections

12 ft beam spacing

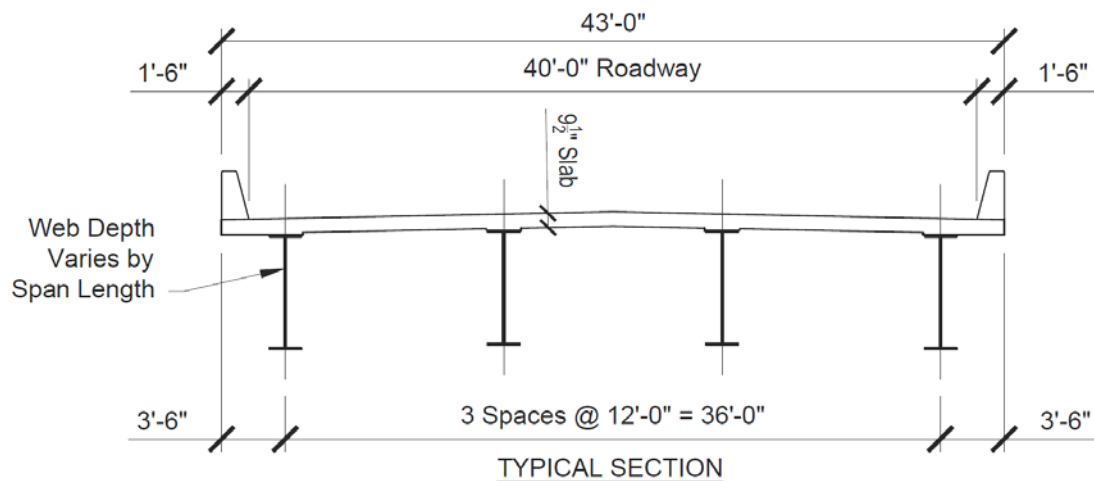

0.29S

14 ft beam spacing

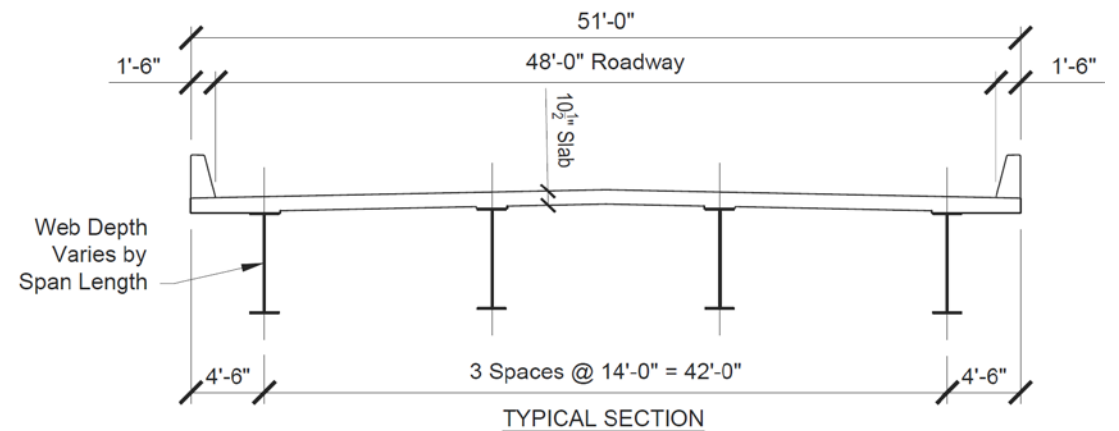

0.32S

Walk-thru of the Standard Plans

3-Span continuous, 12 ft spacing



Standard Plans for Steel Bridges

Three-span
Continuous
Span Bridges

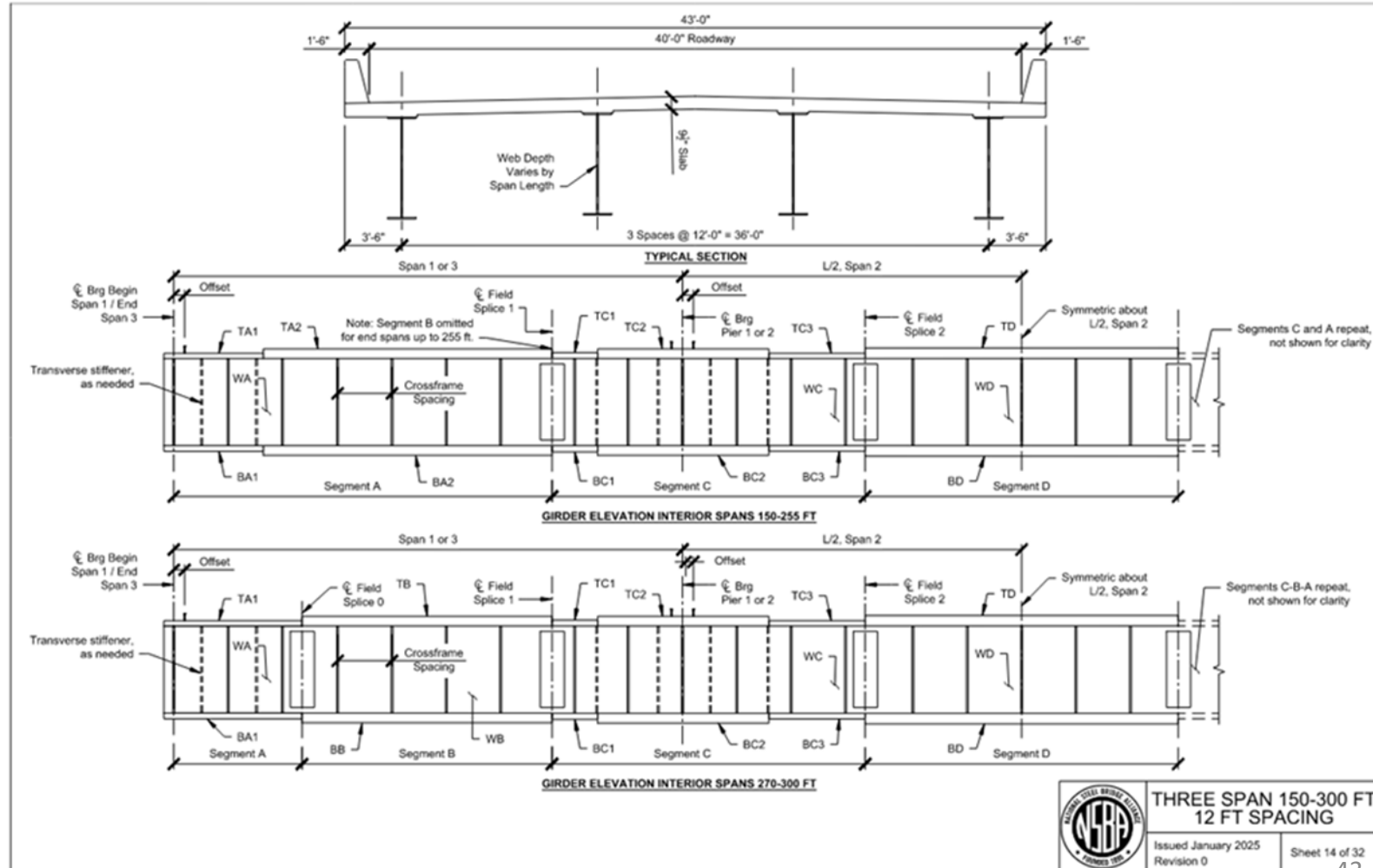

GENERAL NOTES:

Specifications:

AASHTO LRFD Bridge Design Specifications

AASHTO Guide Specifications for Vertical
Construction, 1st Edition.

Materials:

Girder Webs and Flanges

ASTM A709 Gr 50W or Gr HPS 70W

Gr HPS 70W flanges are noted with

Stiffeners

A709 Gr 50W

Intermediate transverse shear stiffeners
Stiffener sizes shown as required by

Lateral Bracing and Diaphragm / Crossframe Members

ASTM A709 Gr 50W

Concrete Deck

$F_c = 4$ ksi

Reinforcing Steel

$F_y = 60$ ksi

Bolts

ASTM F3125 Grade A325, diameter

Dead load assumptions:

For DC1

Slab thickness as shown in plans

Overhang thickness = slab thickness + 4 in.

Concrete haunch weight, 50 plf per beam

Stay-in-place form allowance, 15 psf

Miscellaneous steel weight:

8 ft girder spacing - 30 plf

10 ft girder spacing - 30 plf

12 ft girder spacing - 30 plf

14 ft girder spacing - 45 plf

Total DC1 loads shown on this sheet are computed with the above assumptions and assuming equal loading to all beams in the cross-section.

For DC2

Assumed single slope TL5 railing

600 plf divided to two beams

For DW

2 in. asphalt at 140 pcf

range lateral bending moments from
shing machine. Flange lateral bending
on the **Fascia Beam Design Criteria**

1. see **General Design Criteria** sheet.

GENERAL NOTES

Issued January 2025
Revision 0

Sheet 2 of 32

Design Assumptions and Criteria, Continuous Span Bridges:

1. Girder Design

- a. All designs performed using NSBA LRFD SIMON.
- b. Interior and exterior beams were designed. In LRFD SIMON, the "BOTH" option is used for the LL distribution factors. This results in a single beam designed for the governing shear and moment distribution factors for an interior and exterior beam. The composite slab effective width is based on an exterior beam.
- c. Live load distribution follows AASHTO LRFD 4.6.2.2 for all beam spacings and span lengths. Designs where the AASHTO distribution factor equations are used beyond the range of applicability are noted in the design tables.
- d. A skew of 20 degrees from normal is assumed for all designs.
- e. Live load deflection satisfies AASHTO LRFD 2.5.2.6.2 Criteria for Deflection for vehicular bridges, $L/800$.
- f. Girder depth satisfies AASHTO LRFD 2.5.2.6.3 Optional Criteria for Span-to-Depth Ratios.

3. Wind Load Design

- a. Lateral deflection and flange lateral bending stresses due to wind on the fully erected steel framing were evaluated. Lateral bracing is not required for the design conditions assumed in 3.1 and 3.2, below. Other conditions may require bracing for wind load deflection or stress.

3.1 Service Design Criteria

- a. Lateral deflections due to wind loads on the fully erected steel satisfy the Span / 150 requirement established by PennDOT BD-620M. All references to BD-620M are to the April 29, 2016 edition.
- b. For this deflection check, a 32 psf assumed pressure is applied to fascia beams only for a superstructure height = 30 ft. For other superstructure heights, refer to PennDOT BD-620M.

Design Assumptions and Criteria, Continuous Span Bridges:

1. Girder Design

- a. All designs performed using NSBA LRFD SIMON.
- b. Interior and exterior beams were designed. In LRFD SIMON, the "BOTH" option is used for the LL distribution factors. This results in a single beam designed for the governing shear and moment distribution factors for an interior and exterior beam. The composite slab effective width is based on an exterior beam.
- c. Live load distribution follows AASHTO LRFD 4.6.2.2 for all beam spacings and span lengths. Designs where the AASHTO distribution factor equations are used beyond the range of applicability are noted in the design tables.
- d. A skew of 20 degrees from normal is assumed for all designs.
- e. Live load deflection satisfies AASHTO LRFD 2.5.2.6.2 Criteria for Deflection for vehicular bridges, $L/800$.
- f. Girder depth satisfies AASHTO LRFD 2.5.2.6.3 Optional Criteria for Span-to-Depth Ratios.
- g. Fatigue design based on Category C for shear studs welded to top flanges and Category C' for welded transverse stiffeners, $ADTT_{SL} = 1,000$ vehicles per day and a 75-year design life.
- h. Maximum segment length, 140 feet.

- i. Cross-Frame members are designed as secondary members.
- j. Cross-Frame members are designed for tension / compression loading.
- k. Cross-frame member stiffness is based on 0.65AE stiffness reduction factor for eccentrically loaded angles, AASHTO LRFD C4.6.3.3.4.
- l. Diaphragms and cross-frames are designed for combined stability-induced loads along with simultaneous deck casting forces. The finishing machine is assumed to be centered at a brace point location.

1. Girder Design

- a. All designs performed using NSBA LRFD SIMON.
- b. Interior and exterior beams were designed. In LRFD SIMON, the "BOTH" option is used for the LL distribution factors. This results in a single beam designed for the governing shear and moment distribution factors for an

3. Wind Load Design

- a. Lateral deflection and flange lateral bending stresses due to wind on the fully erected steel framing were evaluated. Lateral bracing is not required for the design conditions assumed in 3.1 and 3.2, below. Other conditions may require bracing for wind load deflection or stress.

3. Wind Load Design

- a. Lateral deflection and flange lateral bending stresses due to wind on the fully erected steel framing were evaluated. Lateral bracing is not required for the design conditions assumed in 3.1 and 3.2, below. Other conditions may require bracing for wind load deflection or stress.

3.1 Service Design Criteria

- a. Lateral deflections due to wind loads on the fully erected steel satisfy the Span / 150 requirement established by PennDOT BD-620M. All references to BD-620M are to the April 29, 2016 edition.
- b. For this deflection check, a 32 psf assumed pressure is applied to fascia beams only for a superstructure height = 30 ft. For other superstructure heights, refer to PennDOT BD-620M.

3.2 Strength Design Criteria

Girder flange lateral bending is checked for strength as follows:

- a. Maximum wind load positive and negative moment regions were checked. Check other plate transitions in final design.
- b. Fascia beam checked for global bending of the span and local bending between cross-frames.
- c. Wind loads on erected steel determined from the *AASHTO Guide Specification for Wind Loads on Bridges During Construction, 2017*.

Inactive wind condition, $V = 115$ mph. Superstructure height, 30 ft

Superstructure construction duration 6 weeks - 1 year, $R = 0.73$

$K_z = 1.0$, $C_d = 2.2$ for fascia beam, per AASHTO Guide Specifications for other beams.

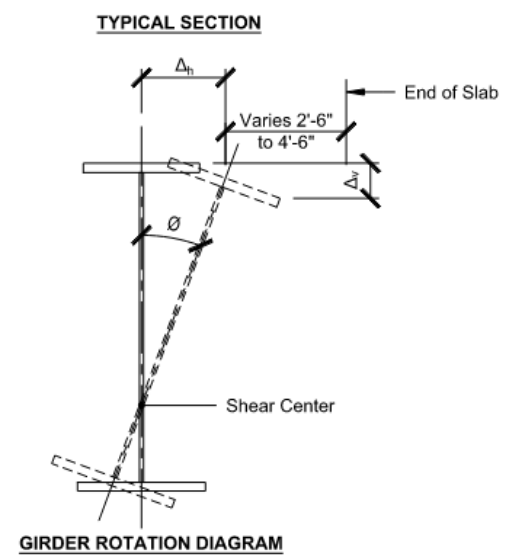
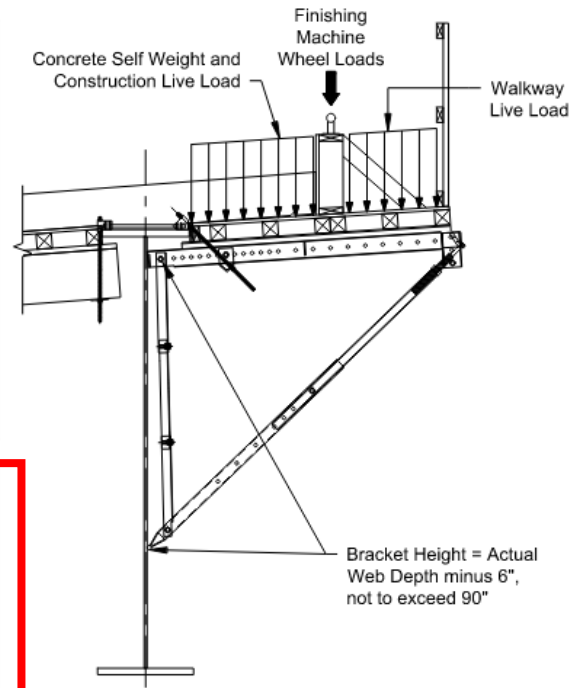
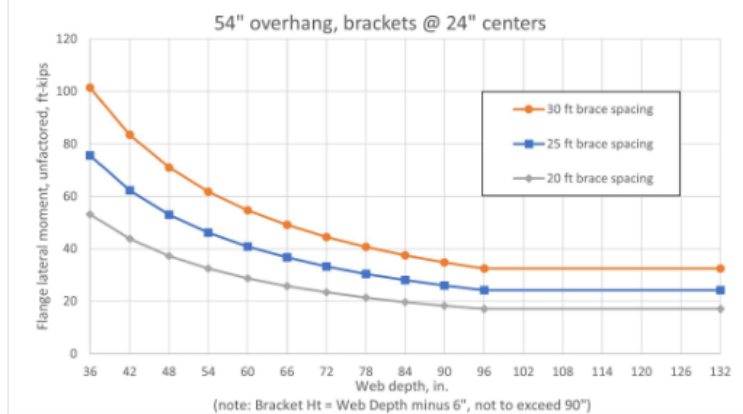
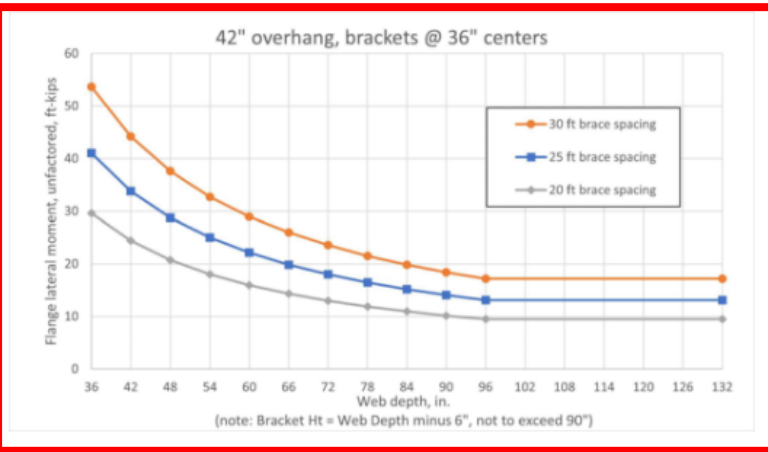
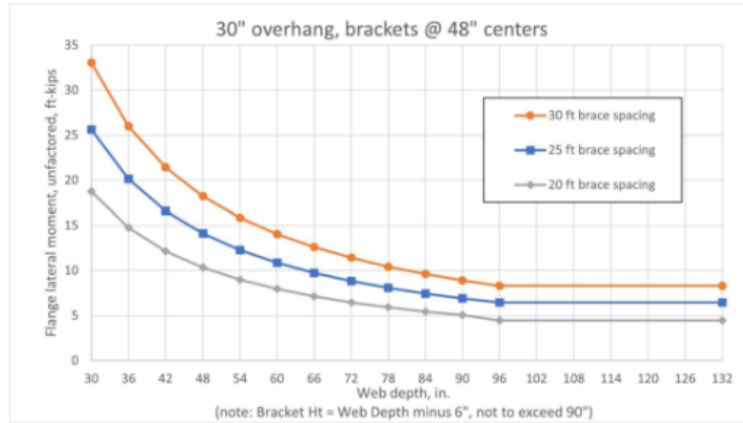

Fascia Beam Design Criteria:

1. Finishing machine wheel load, 4 @ 2000 pounds. Loads shown are representative of finishing machines used for bridge widths and types shown on these plans.
2. Concrete density, 160 pcf, to account for formwork weight allowance.
3. Construction live load on deck, 50 psf.
4. Walkway live load, 50 psf. Assumed walkway width, 2 ft.
5. Overhang slab thickness equals nominal slab thickness + 4 in. assuming slab is flush to underside of top flange and an assumed 4 in. haunch.
6. Finishing machine is assumed to be midway between cross-frames for lateral bending moment calculations.
 - a. Factored load combination: AASHTO LRFD 3.4.2, 1.25 DC + 1.5 LL
 - b. An equivalent service bending moment is computed for LRFD SIMON input. LRFD SIMON uses a 1.4 factor on all lateral bending moments. Moments shown on the accompanying graphs are unfactored and are a total weighted average of the dead and live load lateral flange bending moments.
7. Bracket spacing assumed as follows. Bracket spacing is based on limiting capacities of common commercially available hangers and brackets. Assumed safe working load of 6,000 lbs. per hanger. Assumed safe working load of 3,750 lbs. per diagonal.
 - a. 30 in. overhangs, 48 in. bracket spacing.
 - b. 42 in. overhang, 36 in. bracket spacing.
 - c. 54 in. overhang, 24 in. bracket spacing.
8. Girder service load rotations, ϕ , are limited to 1 degree.
9. Lateral deflection at the top of web, Δ_h , limited to 0.25 in. Vertical deflection of the edge of slab, Δ_v , limited to 0.5 in. Both limits checked for maximum finishing machine loading and are instantaneous values.

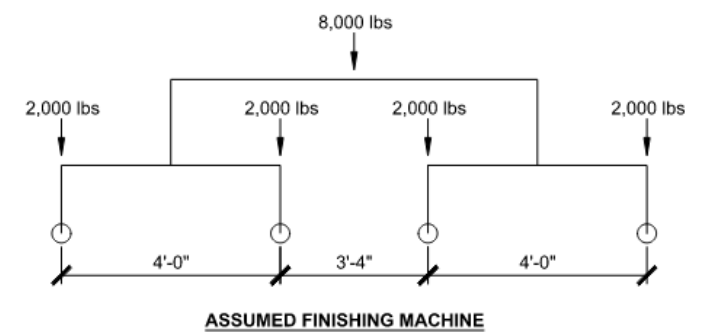

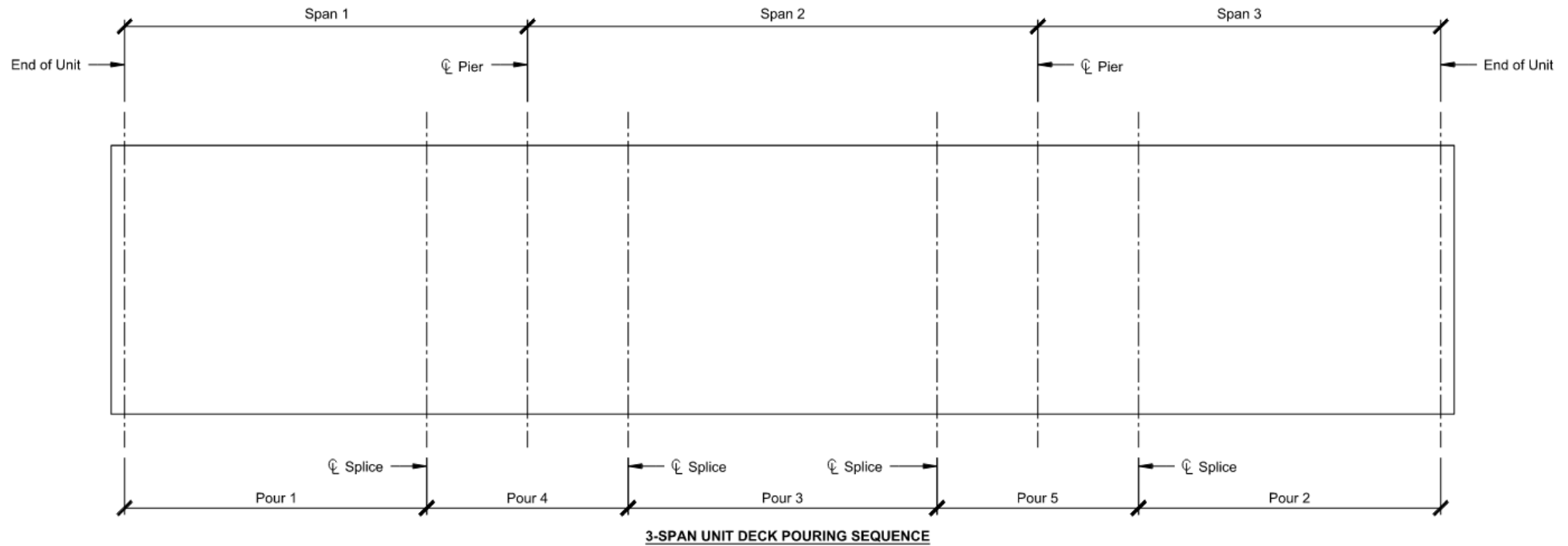

DECK POURING NOTES

1. The deck pouring sequence shown is the basis of design.
2. The beams are designed for local and lateral-torsional buckling limits for the specified pour sequence and additionally for the global stability and cross-frame requirements of AASHTO LRFD 10th edition Article 6.7.4.2.2.
3. For the 3-span unit, the critical checks for deck casting positive and negative bending in noncomposite sections occur during Pour 2 and 5.
4. The provisions of AASHTO LRFD 6.7.4.2.2 do not account for the stiffening influence of any previously cast and composite deck sections and are conservative for other than Pour 1.
5. Uplift is prevented in all cases.

Note: An alternate pouring sequence with the deck cast continuously end-to-end is also permitted. All girder designs in these standards satisfy stress, strength, uplift, and stability requirements for the alternate pouring sequence.

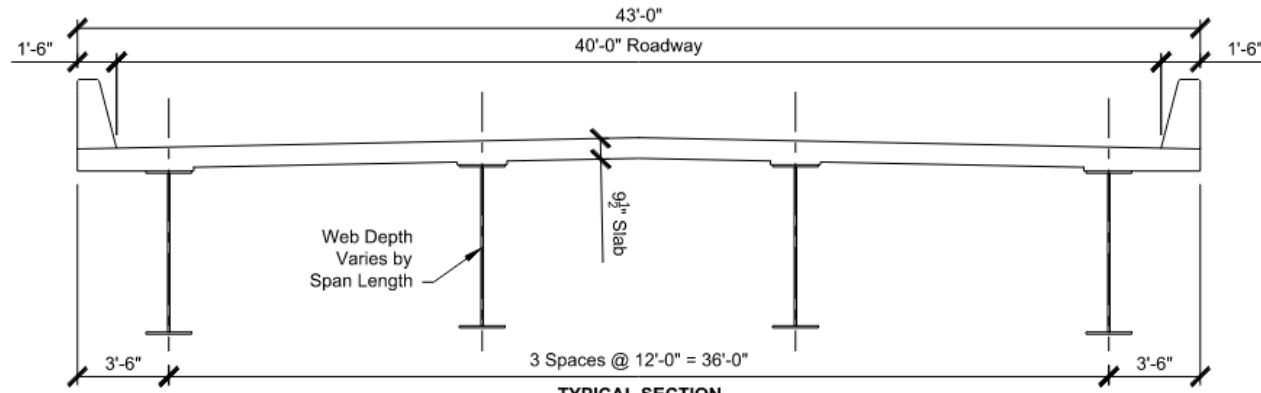

TYPICAL SECTION

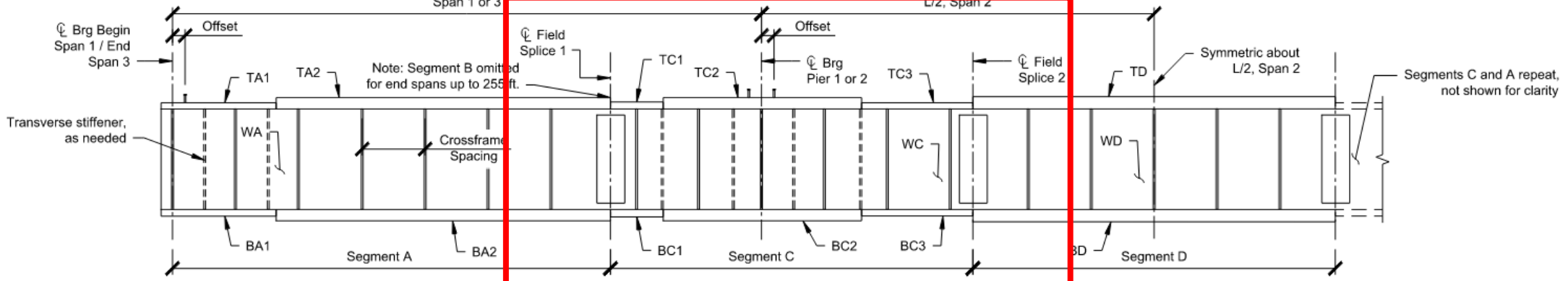

GIRDER ELEVATION INTERIOR SPANS 150-255 FT

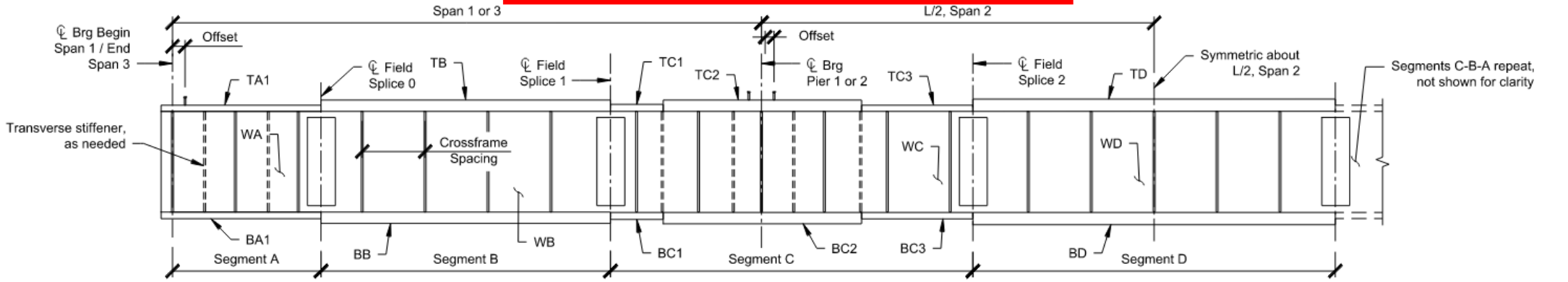

GIRDER ELEVATION INTERIOR SPANS 270-300 FT

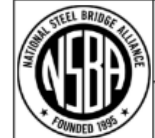

**THREE SPAN 150-300 FT
12 FT SPACING**

Issued January 2025
Revision 0
Sheet 14 of 32

TYPICAL SECTION

L/2, Span 2

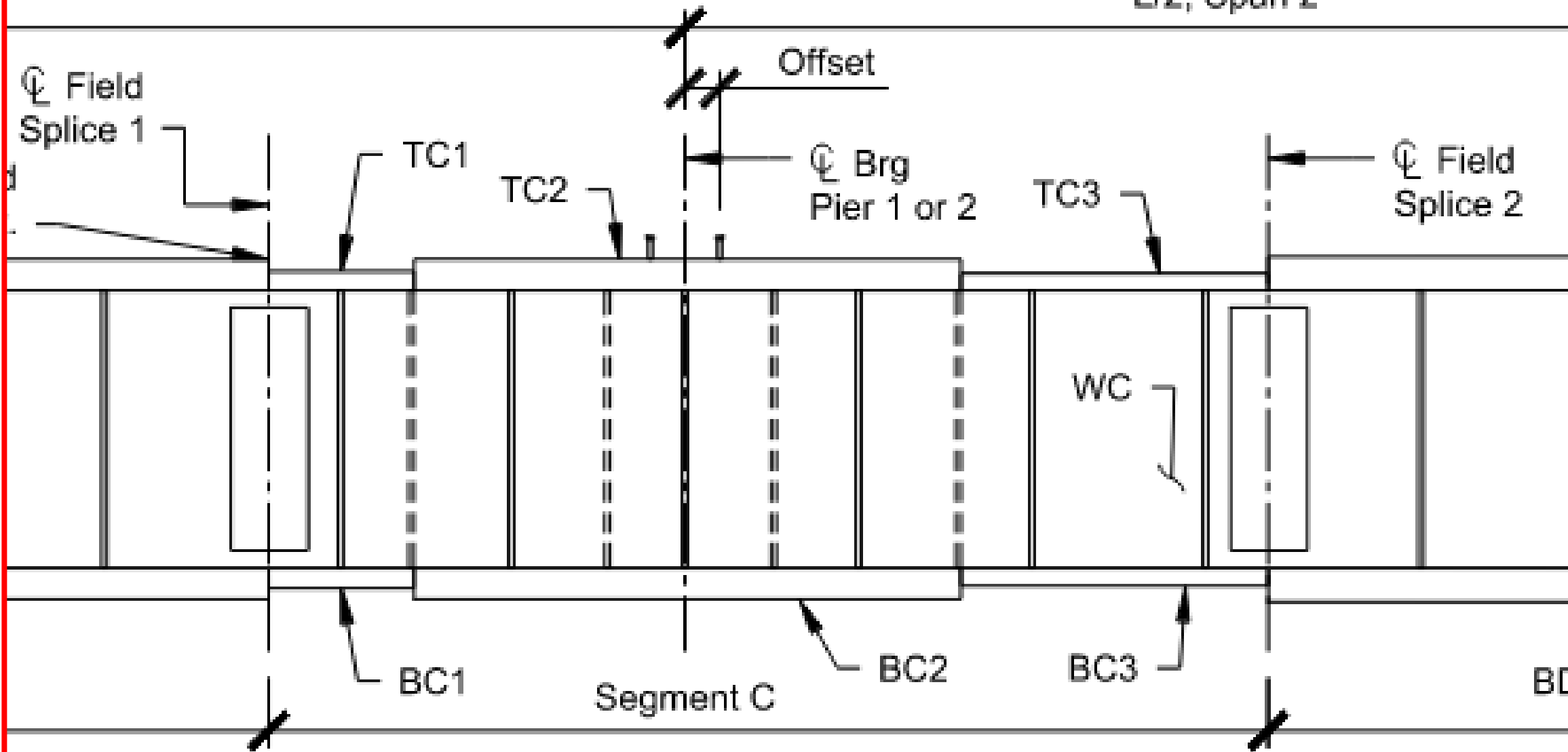

GIRDER ELEVATION INTERIOR SPANS 150-255 FT

Span, ft. End-Int.-End	SEGMENT A					SEGMENT B (as needed)		
	WA (in. x in. x ft.)	TA1 (in. x in. x ft.)	TA2 (in. x in. x ft.)	BA1 (in. x in. x ft.)	BA2 (in. x in. x ft.)	WB (in. x in. x ft.)	TB (in. x in. x ft.)	BB (in. x in. x ft.)
117-150-117	54 x 0.625 x 79	---	16 x 1 x 79	---	22 x 1.5 x 79	---	---	---
129-165-129	62 x 0.625 x 89	---	16 x 1 x 89	---	22 x 1.5 x 89	---	---	---
141-180-141	66 x 0.625 x 98	---	18 x 1 x 98	22 x 1.25 x 49	22 x 1.5 x 49	---	---	---
153-195-153	74 x 0.625 x 106	---	18 x 1 x 106	24 x 1 x 65	24 x 1.25 x 41	---	---	---
164-210-164	78 x 0.625 x 113	---	18 x 1 x 113	24 x 1 x 57	24 x 1.25 x 56	---	---	---
176-225-176	82 x 0.75 x 122	18 x 1 x 61	18 x 1.25 x 61	22 x 1 x 61	22 x 1.5 x 61	---	---	---
188-240-188	88 x 0.75 x 130	---	20 x 1 x 130	24 x 1 x 70	24 x 1.25 x 60	---	---	---
199-255-199	94 x 0.75 x 138	---	20 x 1 x 138	24 x 1 x 84	24 x 1.25 x 54	---	---	---
211-270-211	98 x 0.75 x 51	20 x 1 x 51	---	24 x 1 x 51	---	98 x 0.75 x 100	20 x 1.25 x 100	24 x 1.25 x 100
223-285-223	102 x 0.75 x 51	22 x 1 x 51	---	24 x 1 x 51	---	102 x 0.75 x 110	22 x 1.25 x 110	24 x 1.25 x 110
234-300-234	108 x 0.75 x 54	24 x 1 x 54	---	24 x 1.25 x 54	---	108 x 0.75 x 120	24 x 1.25 x 120	24 x 1.25 x 120

Span, ft. End-Int.-End	SEGMENT C							SEGMENT D			Additional Footnotes
	WC (in. x in. x ft.)	TC1 (in. x in. x ft.)	TC2 (in. x in. x ft.)	TC3 (in. x in. x ft.)	BC1 (in. x in. x ft.)	BC2 (in. x in. x ft.)	BC3 (in. x in. x ft.)	WD (in. x in. x ft.)	TD (in. x in. x ft.)	BD (in. x in. x ft.)	
117-150-117	54 x 0.625 x 76	22 x 1 x 24	22 x 1.75 x 28	22 x 1 x 24	22 x 1.25 x 24	22 x 2.25 x 28	22 x 1.25 x 24	54 x 0.625 x 74	16 x 1 x 74	22 x 1.25 x 74	---
129-165-129	62 x 0.625 x 80	22 x 1 x 25	22 x 2 x 30	22 x 1 x 25	22 x 1.25 x 25	22 x 2.25 x 30	22 x 1.25 x 25	62 x 0.625 x 85	16 x 1 x 85	22 x 1.25 x 85	---
141-180-141	66 x 0.625 x 86	22 x 1 x 27	22 x 2 x 32	22 x 1 x 27	24 x 1.25 x 27	24 x 2.25 x 32	24 x 1.25 x 27	66 x 0.625 x 94	16 x 1 x 94	22 x 1.25 x 94	---
153-195-153	74 x 0.625 x 94	24 x 1 x 28	24 x 2 x 38	24 x 1 x 28	24 x 1.25 x 28	24 x 2.5 x 38	24 x 1.25 x 28	74 x 0.625 x 101	18 x 1 x 101	24 x 1 x 101	---
164-210-164	78 x 0.625 x 102	24 x 1.25 x 25	24 x 2.5 x 47	24 x 1.25 x 30	24 x 1.25 x 25	24 x 2.5 x 47	24 x 1.25 x 30	78 x 0.625 x 108	18 x 1 x 108	22 x 1.25 x 108	---
176-225-176	82 x 0.75 x 108	24 x 1.25 x 32	24 x 2.5 x 44	24 x 1.25 x 32	24 x 1.5 x 32	24 x 2.75 x 44	24 x 1.5 x 32	82 x 0.75 x 117	18 x 1 x 117	22 x 1.25 x 117	---
188-240-188	88 x 0.75 x 116	26 x 1.25 x 34	26 x 2.5 x 53	26 x 1.25 x 29	26 x 1.5 x 34	26 x 2.75 x 53	26 x 1.5 x 29	88 x 0.75 x 124	20 x 1 x 124	20 x 1.25 x 124	---
199-255-199	94 x 0.75 x 122	26 x 1.5 x 35	26 x 2.75 x 52	26 x 1.5 x 35	26 x 1.5 x 35	26 x 2.75 x 52	26 x 1.5 x 35	94 x 0.75 x 133	20 x 1 x 133	24 x 1 x 133	a
211-270-211	98 x 0.75 x 125	26 x 1.5 x 30	26 x 3 x 60	26 x 1.5 x 35	26 x 1.75 x 30	26 x 3 x 60	26 x 1.75 x 35	98 x 0.75 x 140	20 x 1 x 140	24 x 1 x 140	a
223-285-223	102 x 0.75 x 135	30 x 1.25 x 31	30 x 2.5 x 57	30 x 1.25 x 47	30 x 1.5 x 31	30 x 2.75 x 57	30 x 1.5 x 47	102 x 0.75 x 139	22 x 1 x 139	22 x 1.25 x 139	a
234-300-234	108 x 0.75 x 140	28 x 1.5 x 25	28 x 3 x 65	28 x 1.5 x 50	30 x 1.5 x 25	30 x 3 x 65	30 x 1.5 x 50	108 x 0.75 x 140	22 x 1 x 140	24 x 1 x 140	a

Note: All plates are A709 Gr 50W.

Footnotes:

a. AASHTO distribution factor equations were used with girder stiffness and / or span length exceeding AASHTO limits. Check with refined analysis.

Span, ft. End-Int.-End	SEGMENT A				SEGMENT B (as needed)			
	WA (in. x in. x ft.)	TA1	TA2	BA1	BA2	WB	TB	BB
117-150-117	54 x 0.625 x 79							
129-165-129	62 x 0.625 x 89							
141-180-141	66 x 0.625 x 98							
153-195-153	74 x 0.625 x 106							
164-210-164	78 x 0.625 x 113							
176-225-176	82 x 0.75 x 122							
188-240-188	88 x 0.75 x 130							
199-255-199	94 x 0.75 x 138							
211-270-211	98 x 0.75 x 51							
223-285-223	102 x 0.75 x 51							
234-300-234	108 x 0.75 x 54							

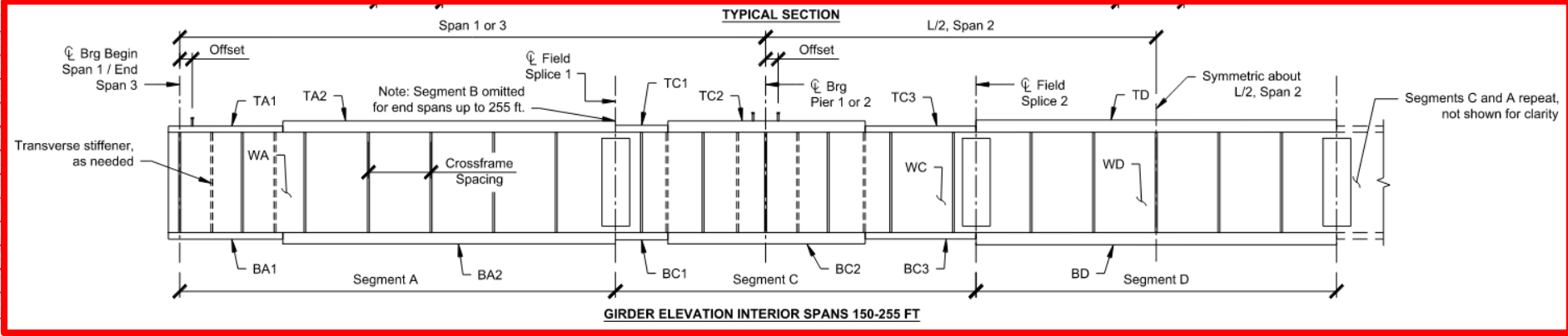

Span, ft. End-Int.-End	WC	TC1	TC2	TC3	BC1	BC2	BC3	WD	TD	BD	Additional
	117-150-117										
129-165-129											
141-180-141											
153-195-153											
164-210-164											
176-225-176											
188-240-188											
199-255-199											
211-270-211											
223-285-223											
234-300-234											

Span, ft. End-Int.-End	SEGMENT A					SEGMENT B (as needed)		
	WA (in. x in. x ft.)	TA1 (in. x in. x ft.)	TA2 (in. x in. x ft.)	BA1 (in. x in. x ft.)	BA2 (in. x in. x ft.)	WB (in. x in. x ft.)	TB (in. x in. x ft.)	BB (in. x in. x ft.)
117-150-117	54 x 0.625 x 79	---	16 x 1 x 79	---	22 x 1.5 x 79	---	---	---
129-165-129	62 x 0.625 x 89	---	16 x 1 x 89	---	22 x 1.5 x 89	---	---	---
141-180-141	66 x 0.625 x 98	---	18 x 1 x 98	22 x 1.25 x 49	22 x 1.5 x 49	---	---	---
153-195-153	74 x 0.625 x 106	---	18 x 1 x 106	24 x 1 x 65	24 x 1.25 x 41	---	---	---
164-210-164	78 x 0.625 x 113	---	18 x 1 x 113	24 x 1 x 57	24 x 1.25 x 56	---	---	---
176-225-176	82 x 0.75 x 122	18 x 1 x 61	18 x 1.25 x 61	22 x 1 x 61	22 x 1.5 x 61	---	---	---
188-240-188	88 x 0.75 x 130	---	20 x 1 x 130	24 x 1 x 70	24 x 1.25 x 60	---	---	---
199-255-199	94 x 0.75 x 138	---	20 x 1 x 138	24 x 1 x 84	24 x 1.25 x 54	---	---	---
211-270-211	98 x 0.75 x 51	20 x 1 x 51	---	24 x 1 x 51	---	98 x 0.75 x 100	20 x 1.25 x 100	24 x 1.25 x 100
223-285-223	102 x 0.75 x 51	22 x 1 x 51	---	24 x 1 x 51	---	102 x 0.75 x 110	22 x 1.25 x 110	24 x 1.25 x 110
234-300-234	108 x 0.75 x 54	24 x 1 x 54	---	24 x 1.25 x 54	---	108 x 0.75 x 120	24 x 1.25 x 120	24 x 1.25 x 120

Note: A
Footnot
a. AA



TRANSVERSE AND BEARING STIFFENERS								
Span, ft. End-Int.-End	Transverse Stiffener Size and Location, Distance From End support, Each Span				Bearing Stiffeners, End		Bearing Stiffeners, Piers	
	Width in.	Thickness in.	Span 1 Location, ft.	Span 2 Location, ft.	Width in.	Thickness in.	Width in.	Thickness in.
117-150-117	---	---	---	---	7.25	0.75	10.25	1
129-165-129	5.5	0.5	113.5	15.5, 149.5	7.25	0.75	10.25	1
141-180-141	6	0.5	108, 124.5	16.5, 33, 147, 163.5	8.25	0.75	10.25	1
153-195-153	6	0.5	116, 134.5	18.5, 37, 158, 176.5	8.25	0.75	11.25	1
164-210-164	7	0.5	9.75, 125, 144.5	19.5, 39, 171, 190.5	8.25	0.75	11.25	1

DEAD AND LIVE LOAD REACTIONS								
Span, ft. End-Int.-End	End Reaction				Pier 1 & 2 Reaction			
	DC kips	DW kips	Truck kips	Lane kips	DC kips	DW kips	Truck kips	Lane kips
117-150-117	88	10	100	40	322	36	173	106
129-165-129	98	11	101	44	358	40	177	117
141-180-141	107	12	101	48	393	43	181	128
153-195-153	116	13	102	52	432	47	184	139
164-210-164	123	14	102	55	472	51	186	149

TRANSVERSE AND BEARING STIFFENERS								
Span, ft. End-Int.-End	Transverse Stiffener Size and Location, Distance From End support, Each Span				Bearing Stiffeners, End		Bearing Stiffeners, Piers	
	Width in.	Thickness in.	Span 1 Location, ft.	Span 2 Location, ft.	Width in.	Thickness in.	Width in.	Thickness in.
117-150-117	---	---	---	---	7.25	0.75	10.25	1
129-165-129	5.5	0.5	113.5	15.5, 149.5	7.25	0.75	10.25	1
141-180-141	6	0.5	108, 124.5	16.5, 33, 147, 163.5	8.25	0.75	10.25	1
153-195-153	6	0.5	116, 134.5	18.5, 37, 158, 176.5	8.25	0.75	11.25	1
164-210-164	7	0.5	9.75, 125, 144.5	19.5, 39, 171, 190.5	8.25	0.75	11.25	1
176-225-176	6	0.5	155.5	20.5, 204.5	8	0.75	11	1
188-240-188	6.5	0.5	166	22, 218	9	0.875	12	1.125
199-255-199	6.5	0.5	152, 175.5	23.5, 47, 208, 231.5	9	0.875	12	1.125
211-270-211	7.25	0.5	162, 186.5	24.5, 49, 221, 245.5	9	0.875	12	1.125
223-285-223	8	0.625	12.75, 172, 197.5	25.5, 51, 234, 259.5	10	0.875	14	1.25
234-300-234	9	0.625	13.5, 147, 174, 180, 207	27, 54, 246, 273	11	1	13	1.125

Span, ft. End-Int.-End	End Span	Interior Span	Type
117-150-117	4 @ 20.5 + 2 @ 17.5 = 117	2 @ 17.5 + 3 @ 26.66 + 2 @ 17.5 = 150	K-Frame
129-165-129	4 @ 23 + 2 @ 18.5 = 129	2 @ 18.5 + 4 @ 22.75 + 2 @ 18.5 = 165	K-Frame
141-180-141	4 @ 25.25 + 2 @ 20 = 141	2 @ 20 + 4 @ 25 + 2 @ 20 = 180	K-Frame
153-195-153	5 @ 22 + 2 @ 21.5 = 153	2 @ 21.5 + 4 @ 27.25 + 2 @ 21.5 = 195	K-Frame
164-210-164	5 @ 23 + 3 @ 16.33 = 164	3 @ 16.25 + 5 @ 22.5 + 3 @ 16.25 = 210	K-Frame
176-225-176	5 @ 25 + 3 @ 17 = 176	3 @ 16.66 + 5 @ 25 + 3 @ 16.66 = 225	K-Frame
188-240-188	5 @ 26.5 + 3 @ 18.5 = 188	3 @ 17.91 + 5 @ 26.5 + 3 @ 17.91 = 240	K-Frame
199-255-199	6 @ 23.5 + 3 @ 19.33 = 199	3 @ 18.75 + 5 @ 28.5 + 3 @ 18.75 = 255	K-Frame
211-270-211	6 @ 24.67 + 3 @ 21 = 211	3 @ 21 + 6 @ 24 + 3 @ 21 = 270	K-Frame
223-285-223	6 @ 26.5 + 3 @ 21.33 = 223	4 @ 17.5 + 6 @ 24.16 + 4 @ 17.5 = 285	K-Frame
234-300-234	8 @ 23.25 + 3 @ 16 = 234	4 @ 19 + 6 @ 24.66 + 4 @ 19 = 300	K-Frame

bearing, stiffeners, shear studs, bracing, or any other allowances.



THREE SPAN 150-300 FT
12 FT SPACING

Issued January 2025
Revision 0

Sheet 16 of 32

TRANSVERSE AND BEARING STIFFENERS										
Span, ft. End-Int.-End	Transverse Stiffener Size and Location, Distance From End support, Each Span					Bearing Stiffeners, End		Bearing Stiffeners, Piers		
	Width in.	Thickness in.	Span 1 Location, ft.		Span 2 Location, ft.		Width in.	Thickness in.	Width in.	Thickness in.
117-150-117	---	---	---		---		7.25	0.75	10.25	1
129-165-129	5.5	0.5	113.5		15.5, 149.5		7.25	0.75	10.25	1
141-180-141	6	0.5	108, 124.5		16.5, 33, 147, 163.5		8.25	0.75	10.25	1
153-195-153	6	0.5	116, 134.5		18.5, 37, 158, 176.5		8.25	0.75	11.25	1

DEAD AND LIVE LOAD REACTIONS								
Span, ft. End-Int.-End	End Reaction				Pier 1 & 2 Reaction			
	DC kips	DW kips	Truck kips	Lane kips	DC kips	DW kips	Truck kips	Lane kips
117-150-117	88	10	100	40	322	36	173	106
129-165-129	98	11	101	44	358	40	177	117
141-180-141	107	12	101	48	393	43	181	128
153-195-153	116	13	102	52	432	47	184	139

SHEAR STUD LAYOUT																					
Span, ft. End-Int.-End	Studs per row	Span 1										Span 2									
		Offset in.	Group 1			Group 2			Group 3			Offset in.	Group 1			Group 2			Group 3		
			Spaces	Pitch in.	Length ft.	Spaces	Pitch in.	Length ft.	Spaces	Pitch in.	Length ft.		Spaces	Pitch in.	Length ft.	Spaces	Pitch in.	Length ft.	Spaces	Pitch in.	Length ft.
117-150-117	4	0	27	8	18	90	12	90	3	36	9	0	15	24	30	90	12	90	15	24	30
129-165-129	4	0	13	6	6.5	91	12	91	10	36	30	0	13	30	32.5	100	12	100	13	30	32.5
141-180-141	4	0	14	6	7	99	12	99	11	36	33	0	14	30	35	110	12	110	14	30	35
153-195-153	4	0	115	12	115	7	42	24.5	3	48	12	0	13	36	39	117	12	117	13	36	39
164-210-164	4	0	123	12	123	10	48	40	---	---	---	0	12	42	42	126	12	126	12	42	42
176-225-176	4	0	132	12	132	10	48	40	---	---	---	6	11	48	44	136	12	136	11	48	44
188-240-188	4	0	19	12	19	92	16	122.67	11	48	44	0	12	48	48	144	12	144	12	48	48
199-255-199	4	0	30	12	30	80	18	120	12	48	48	30	12	48	48	154	12	154	12	48	48
211-270-211	4	0	32	12	32	85	18	127.5	12	48	48	6	13	48	52	109	18	163.5	13	48	52
223-285-223	4	0	23	12	23	97	18	145.5	13	48	52	12	14	48	56	114	18	171	14	48	56
234-300-234	4	0	12	12	12	102	18	153	17	48	68	36	14	48	56	121	18	181.5	14	48	56

129-165-129	4 @ 23 + 2 @ 18.5 = 129	2 @ 18.5 + 4 @ 22.75 + 2 @ 18.5 = 165	K-Frame
141-180-141	4 @ 25.25 + 2 @ 20 = 141	2 @ 20 + 4 @ 25 + 2 @ 20 = 180	K-Frame
153-195-153	5 @ 22 + 2 @ 21.5 = 153	2 @ 21.5 + 4 @ 27.25 + 2 @ 21.5 = 195	K-Frame
164-210-164	5 @ 23 + 3 @ 16.33 = 164	3 @ 16.25 + 5 @ 22.5 + 3 @ 16.25 = 210	K-Frame
176-225-176	5 @ 25 + 3 @ 17 = 176	3 @ 16.66 + 5 @ 25 + 3 @ 16.66 = 225	K-Frame
188-240-188	5 @ 26.5 + 3 @ 18.5 = 188	3 @ 17.91 + 5 @ 26.5 + 3 @ 17.91 = 240	K-Frame
199-255-199	6 @ 23.5 + 3 @ 19.33 = 199	3 @ 18.75 + 5 @ 28.5 + 3 @ 18.75 = 255	K-Frame
211-270-211	6 @ 24.67 + 3 @ 21 = 211	3 @ 21 + 6 @ 24 + 3 @ 21 = 270	K-Frame
223-285-223	6 @ 26.5 + 3 @ 21.33 = 223	4 @ 17.5 + 6 @ 24.16 + 4 @ 17.5 = 285	K-Frame
234-300-234	8 @ 23.25 + 3 @ 16 = 234	4 @ 19 + 6 @ 24.66 + 4 @ 19 = 300	K-Frame



THREE SPAN 150-300 FT
12 FT SPACING

Issued January 2025
Revision 0

Sheet 16 of 32

TRANSVERSE AND BEARING STIFFENERS								
Span, ft. End-Int.-End	Transverse Stiffener Size and Location, Distance From End support, Each Span				Bearing Stiffeners, End		Bearing Stiffeners, Piers	
	Width in.	Thickness in.	Span 1 Location, ft.	Span 2 Location, ft.	Width in.	Thickness in.	Width in.	Thickness in.

DEAD AND LIVE LOAD REACTIONS								
Span, ft. End-Int.-End	End Reaction				Pier 1 & 2 Reaction			
	DC kips	DW kips	Truck kips	Lane kips	DC kips	DW kips	Truck kips	Lane kips

CROSS-FRAME SPACING

Span, ft. End-Int.-End	End Span	Interior Span	Type
117-150-117	4 @ 20.5 + 2 @ 17.5 = 117	2 @ 17.5 + 3 @ 26.66 + 2 @ 17.5 = 150	K-Frame
129-165-129	4 @ 23 + 2 @ 18.5 = 129	2 @ 18.5 + 4 @ 22.75 + 2 @ 18.5 = 165	K-Frame
141-180-141	4 @ 25.25 + 2 @ 20 = 141	2 @ 20 + 4 @ 25 + 2 @ 20 = 180	K-Frame
153-195-153	5 @ 22 + 2 @ 21.5 = 153	2 @ 21.5 + 4 @ 27.25 + 2 @ 21.5 = 195	K-Frame
164-210-164	5 @ 23 + 3 @ 16.33 = 164	3 @ 16.25 + 5 @ 22.5 + 3 @ 16.25 = 210	K-Frame
176-225-176	5 @ 25 + 3 @ 17 = 176	3 @ 16.66 + 5 @ 25 + 3 @ 16.66 = 225	K-Frame
188-240-188	5 @ 26.5 + 3 @ 18.5 = 188	3 @ 17.91 + 5 @ 26.5 + 3 @ 17.91 = 240	K-Frame
199-255-199	6 @ 23.5 + 3 @ 19.33 = 199	3 @ 18.75 + 5 @ 28.5 + 3 @ 18.75 = 255	K-Frame
211-270-211	6 @ 24.67 + 3 @ 21 = 211	3 @ 21 + 6 @ 24 + 3 @ 21 = 270	K-Frame
223-285-223	6 @ 26.5 + 3 @ 21.33 = 223	4 @ 17.5 + 6 @ 24.16 + 4 @ 17.5 = 285	K-Frame
234-300-234	8 @ 23.25 + 3 @ 16 = 234	4 @ 19 + 6 @ 24.66 + 4 @ 19 = 300	K-Frame

188-240-188	5 @ 26.5 + 3 @ 18.5 = 188	3 @ 17.91 + 5 @ 26.5 + 3 @ 17.91 = 240	K-Frame
199-255-199	6 @ 23.5 + 3 @ 19.33 = 199	3 @ 18.75 + 5 @ 28.5 + 3 @ 18.75 = 255	K-Frame
211-270-211	6 @ 24.67 + 3 @ 21 = 211	3 @ 21 + 6 @ 24 + 3 @ 21 = 270	K-Frame
223-285-223	6 @ 26.5 + 3 @ 21.33 = 223	4 @ 17.5 + 6 @ 24.16 + 4 @ 17.5 = 285	K-Frame
234-300-234	8 @ 23.25 + 3 @ 16 = 234	4 @ 19 + 6 @ 24.66 + 4 @ 19 = 300	K-Frame



THREE SPAN 150-300 FT
12 FT SPACING

Issued January 2025
Revision 0

Sheet 16 of 32

TRANSVERSE AND BEARING STIFFENERS

DEAD AND LIVE LOAD REACTIONS

Span, ft. End-Int.-End	Width in.
117-150-117	---
129-165-129	5.5
141-180-141	6
153-195-153	6
164-210-164	7
176-225-176	6
188-240-188	6.5
199-255-199	6.5
211-270-211	7.25
223-285-223	8
234-300-234	9

Span, ft. End-Int.-End	Studs per row	Offse in.
117-150-117	4	0
129-165-129	4	0
141-180-141	4	0
153-195-153	4	0
164-210-164	4	0
176-225-176	4	0
188-240-188	4	0
199-255-199	4	0
211-270-211	4	0
223-285-223	4	0
234-300-234	4	0

Span, ft. End-Int.-End	End
117-150-117	4 @ 20.5 + 2
129-165-129	4 @ 23 + 2
141-180-141	4 @ 25.25 + 2
153-195-153	5 @ 22 + 2
164-210-164	5 @ 23 + 3
176-225-176	5 @ 25 + 3
188-240-188	5 @ 26.5 + 3
199-255-199	6 @ 23.5 + 3
211-270-211	6 @ 24.67 + 3
223-285-223	6 @ 26.5 + 3 @ 21.33 = 22.5
234-300-234	8 @ 23.25 + 3 @ 16 = 234

Span, ft. End-Int.-End	End Reaction				Pier 1 & 2 Reaction			
	DC kips	DW kips	Truck kips	Lane kips	DC kips	DW kips	Truck kips	Lane kips
117-150-117	88	10	100	40	322	36	173	106
129-165-129	98	11	101	44	358	40	177	117
141-180-141	107	12	101	48	393	43	181	128
153-195-153	116	13	102	52	432	47	184	139
164-210-164	123	14	102	55	472	51	186	149
176-225-176	136	15	103	59	517	54	187	159
188-240-188	145	16	103	63	561	58	188	171
199-255-199	154	17	103	66	601	62	189	181
211-270-211	165	18	103	70	646	65	190	192
223-285-223	178	19	104	74	684	69	190	202
234-300-234	187	20	104	78	731	73	191	213

Note: Truck and lane reactions include distribution factors, skew correction, and impact on the truck loading.

Reaction		Pier 1 & 2 Reaction			
Truck kips	Lane kips	DC kips	DW kips	Truck kips	Lane kips
100	40	322	36	173	106
101	44	358	40	177	117
101	48	393	43	181	128
102	52	432	47	184	139
102	55	472	51	186	149
103	59	517	54	187	159
103	63	561	58	188	171
103	66	601	62	189	181
103	70	646	65	190	192
104	74	684	69	190	202
104	78	731	73	191	213

Reactions include distribution factors, skew correction, and impact on truck loading.

WEIGHT		
Segment C tons	Segment D tons	Total tons
12.60	9.73	57.17
14.26	11.89	66.98
16.15	13.55	75.70
19.52	15.16	86.88
23.67	17.32	100.70
27.92	21.30	122.49
33.00	23.42	139.30
36.57	25.91	153.93
40.90	27.99	173.91
43.79	29.80	188.80
49.64	30.25	211.91

Weights of web and flanges only measured and do not include girder extension at end of span, or any other allowances.

THREE SPAN 150-300 FT
12 FT SPACING



TRANSVERSE AND BEARING STIFFENERS

DEAD AND LIVE LOAD REACTIONS

Span, ft. End-Int.-End	Width in.	Th
117-150-117	---	
129-165-129	5.5	
141-180-141	6	
153-195-153	6	
164-210-164	7	
176-225-176	6	
188-240-188	6.5	
199-255-199	6.5	
211-270-211	7.25	
223-285-223	8	
234-300-234	9	

Span, ft. End-Int.-End	Studs per row	Offset in.
117-150-117	4	0
129-165-129	4	0
141-180-141	4	0
153-195-153	4	0
164-210-164	4	0
176-225-176	4	0
188-240-188	4	0
199-255-199	4	0
211-270-211	4	0
223-285-223	4	0
234-300-234	4	0

Span, ft. End-Int.-End	End
117-150-117	4 @ 20.5 + 2
129-165-129	4 @ 23 + 2
141-180-141	4 @ 25.25 +
153-195-153	5 @ 22 + 2
164-210-164	5 @ 23 + 3 @
176-225-176	5 @ 25 + 3
188-240-188	5 @ 26.5 + 3
199-255-199	6 @ 23.5 + 3
211-270-211	6 @ 24.67 +
223-285-223	6 @ 26.5 + 3
234-300-234	8 @ 23.25 + 3 @ 16 = 234

GIRDER WEIGHT					
Span, ft. End-Int.-End	Segment A tons	Segment B tons	Segment C tons	Segment D tons	Total tons
117-150-117	11.12	---	12.60	9.73	57.17
129-165-129	13.29	---	14.26	11.89	66.98
141-180-141	14.92	---	16.15	13.55	75.70
153-195-153	16.33	---	19.52	15.16	86.88
164-210-164	18.02	---	23.67	17.32	100.70
176-225-176	22.68	---	27.92	21.30	122.49
188-240-188	24.94	---	33.00	23.42	139.30
199-255-199	27.43	---	36.57	25.91	153.93
211-270-211	10.20	21.86	40.90	27.99	173.91
223-285-223	10.63	25.08	43.79	29.80	188.80
234-300-234	12.40	28.79	49.64	30.25	211.91

Note: Girder weight is total weight of web and flanges only measured between CL brg at each end. Does not include girder extension at end bearings, stiffeners, shear studs, bracing, or any other allowances.

Lane kips	Pier 1 & 2 Reaction			
	DC kips	DW kips	Truck kips	Lane kips
40	322	36	173	106
44	358	40	177	117
48	393	43	181	128
52	432	47	184	139
55	472	51	186	149
59	517	54	187	159
63	561	58	188	171
66	601	62	189	181
70	646	65	190	192
74	684	69	190	202
78	731	73	191	213

... distribution factors, skew loading.

Segment C tons	Segment D tons	Total tons
50	9.73	57.17
26	11.89	66.98
15	13.55	75.70
52	15.16	86.88
67	17.32	100.70
92	21.30	122.49
00	23.42	139.30
57	25.91	153.93
90	27.99	173.91
79	29.80	188.80
54	30.25	211.91

... and flanges only measured include girder extension at end any other allowances.

FREE SPAN 150-300 FT
12 FT SPACING



Span, ft. End-int-End	DEAD LOAD DEFLECTIONS, SPAN 1 AND L/2 SPAN 2 SHOWN, SYMMETRIC																
	Span Tenth Points and Deflections, in. Span 1										Span Tenth Points and Deflections, in. Span 2						
	1.0	1.1	1.2	1.3	1.4	1.5	1.6	1.7	1.8	1.9	1.10	2.0	2.1	2.2	2.3	2.4	2.5
117-150-117 ft. span - steel only, in.	0.00	0.13	0.24	0.31	0.34	0.32	0.26	0.18	0.09	0.03	0.00	0.00	0.04	0.14	0.27	0.36	0.39
slab, in.	0.00	0.69	1.26	1.63	1.76	1.65	1.33	0.88	0.42	0.10	0.00	0.00	0.28	0.93	1.67	2.23	2.44
barrier rails, in.	0.00	0.06	0.12	0.15	0.16	0.15	0.13	0.08	0.04	0.01	0.00	0.00	0.03	0.11	0.18	0.24	0.26
117-150-117 ft. span - total, in.	0.00	0.88	1.52	2.10	2.27	2.12	1.72	1.15	0.56	0.14	0.00	0.00	0.35	1.17	2.12	2.83	3.09
129-165-129 ft. span - steel only, in.	0.00	0.15	0.28	0.36	0.39	0.37	0.31	0.21	0.11	0.03	0.00	0.00	0.04	0.16	0.30	0.40	0.44
slab, in.	0.00	0.75	1.37	1.78	1.92	1.80	1.45	0.96	0.46	0.12	0.00	0.00	0.28	0.96	1.75	2.35	2.57
barrier rails, in.	0.00	0.07	0.13	0.17	0.19	0.18	0.14	0.10	0.05	0.01	0.00	0.00	0.04	0.12	0.20	0.26	0.29
129-165-129 ft. span - total, in.	0.00	0.98	1.79	2.31	2.50	2.34	1.90	1.27	0.62	0.16	0.00	0.00	0.36	1.23	2.24	3.01	3.29
141-180-141 ft. span - steel only, in.	0.00	0.19	0.35	0.46	0.49	0.46	0.38	0.26	0.13	0.04	0.00	0.00	0.05	0.20	0.37	0.50	0.55
slab, in.	0.00	0.93	1.59	2.18	2.33	2.18	1.75	1.16	0.56	0.14	0.00	0.00	0.34	1.16	2.11	2.84	3.11
barrier rails, in.	0.00	0.09	0.17	0.22	0.24	0.22	0.18	0.12	0.06	0.01	0.00	0.00	0.04	0.14	0.24	0.32	0.34
141-180-141 ft. span - total, in.	0.00	1.21	2.21	2.85	3.07	2.86	2.31	1.54	0.76	0.19	0.00	0.00	0.43	1.49	2.72	3.66	4.00
153-195-153 ft. span - steel only, in.	0.00	0.22	0.40	0.51	0.55	0.52	0.42	0.29	0.15	0.04	0.00	0.00	0.05	0.21	0.40	0.54	0.60
slab, in.	0.00	1.05	1.92	2.48	2.66	2.47	1.98	1.32	0.65	0.18	0.00	0.00	0.29	1.10	2.07	2.81	3.09
barrier rails, in.	0.00	0.11	0.20	0.26	0.28	0.26	0.21	0.14	0.07	0.02	0.00	0.00	0.04	0.14	0.25	0.34	0.37
153-195-153 ft. span - total, in.	0.00	1.38	2.52	3.25	3.49	3.25	2.62	1.75	0.87	0.24	0.00	0.00	0.39	1.45	2.72	3.69	4.05
164-210-164 ft. span - steel only, in.	0.00	0.25	0.46	0.59	0.64	0.60	0.49	0.33	0.18	0.06	0.00	0.00	0.05	0.22	0.43	0.59	0.65
slab, in.	0.00	1.18	2.15	2.75	2.94	2.73	2.20	1.48	0.76	0.24	0.00	0.00	0.27	1.05	2.05	2.83	3.13
barrier rails, in.	0.00	0.13	0.23	0.30	0.32	0.30	0.24	0.16	0.08	0.02	0.00	0.00	0.05	0.15	0.28	0.37	0.40
164-210-164 ft. span - total, in.	0.00	1.56	2.34	3.64	3.90	3.63	2.92	1.97	1.02	0.32	0.00	0.00	0.37	1.42	2.75	3.79	4.18
176-225-176 ft. span - steel only, in.	0.00	0.33	0.59	0.76	0.81	0.75	0.61	0.42	0.21	0.06	0.00	0.00	0.08	0.31	0.59	0.81	0.89
slab, in.	0.00	1.30	2.35	2.99	3.15	2.90	2.31	1.53	0.75	0.20	0.00	0.00	0.38	1.37	2.56	3.48	3.82
barrier rails, in.	0.00	0.15	0.27	0.34	0.36	0.34	0.27	0.18	0.09	0.02	0.00	0.00	0.06	0.18	0.33	0.44	0.48
176-225-176 ft. span - total, in.	0.00	1.77	3.21	4.08	4.31	3.99	3.20	2.13	1.05	0.29	0.00	0.00	0.52	1.87	3.48	4.72	5.19
188-240-188 ft. span - steel only, in.	0.00	0.36	0.55	0.83	0.89	0.83	0.66	0.44	0.22	0.06	0.00	0.00	0.11	0.35	0.64	0.88	0.96
slab, in.	0.00	1.41	2.56	3.28	3.50	3.23	2.57	1.69	0.83	0.22	0.00	0.00	0.39	1.31	2.46	3.38	3.73
barrier rails, in.	0.00	0.16	0.29	0.38	0.41	0.38	0.30	0.20	0.10	0.02	0.00	0.00	0.06	0.19	0.34	0.46	0.50
188-240-188 ft. span - total, in.	0.00	1.92	3.50	4.49	4.79	4.43	3.53	2.33	1.14	0.30	0.00	0.00	0.56	1.85	3.45	4.72	5.19
199-255-199 ft. span - steel only, in.	0.00	0.40	0.73	0.94	1.01	0.93	0.75	0.50	0.25	0.07	0.00	0.00	0.11	0.37	0.69	0.95	1.04
slab, in.	0.00	1.50	2.73	3.51	3.74	3.44	2.73	1.79	0.87	0.23	0.00	0.00	0.42	1.41	2.64	3.64	4.02
barrier rails, in.	0.00	0.18	0.32	0.41	0.44	0.41	0.33	0.22	0.11	0.03	0.00	0.00	0.07	0.21	0.38	0.51	0.56
199-255-199 ft. span - total, in.	0.00	2.08	3.78	4.86	5.18	4.78	3.80	2.51	1.23	0.33	0.00	0.00	0.60	1.99	3.71	5.10	5.62
211-270-211 ft. span - steel only, in.	0.00	0.46	0.83	1.07	1.15	1.07	0.87	0.58	0.30	0.09	0.00	0.00	0.11	0.40	0.75	1.04	1.15
slab, in.	0.00	1.57	2.34	3.61	3.83	3.53	2.79	1.81	0.86	0.21	0.00	0.00	0.50	1.60	2.99	4.11	4.53
barrier rails, in.	0.00	0.19	0.35	0.45	0.48	0.44	0.36	0.23	0.11	0.03	0.00	0.00	0.08	0.24	0.42	0.57	0.62
211-270-211 ft. span - total, in.	0.00	2.23	4.32	5.12	5.46	5.04	4.01	2.63	1.27	0.33	0.00	0.00	0.69	2.24	4.17	5.72	6.31
223-285-223 ft. span - steel only, in.	0.00	0.54	0.98	1.25	1.35	1.26	1.02	0.69	0.36	0.11	0.00	0.00	0.13	0.51	0.97	1.33	1.47
slab, in.	0.00	1.80	3.25	4.14	4.42	4.10	3.28	2.18	1.07	0.30	0.00	0.00	0.49	1.83	3.46	4.74	5.21
barrier rails, in.	0.00	0.22	0.41	0.52	0.56	0.52	0.42	0.28	0.14	0.04	0.00	0.00	0.08	0.26	0.47	0.64	0.70
223-285-223 ft. span - total, in.	0.00	2.56	4.53	5.91	6.33	5.89	4.73	3.15	1.57	0.44	0.00	0.00	0.70	2.60	4.90	6.70	7.38
234-300-234 ft. span - steel only, in.	0.00	0.57	1.04	1.33	1.44	1.34	1.08	0.73	0.37	0.11	0.00	0.00	0.13	0.51	0.99	1.37	1.52
slab, in.	0.00	1.75	3.17	4.05	4.32	3.98	3.14	2.04	0.96	0.23	0.00	0.00	0.57	1.93	3.63	4.98	5.49
barrier rails, in.	0.00	0.22	0.41	0.53	0.57	0.53	0.42	0.28	0.13	0.03	0.00	0.00	0.09	0.28	0.51	0.69	0.75
234-300-234 ft. span - total, in.	0.00	2.54	4.51	5.91	6.32	5.85	4.65	3.04	1.46	0.37	0.00	0.00	0.79	2.72	5.13	7.04	7.76

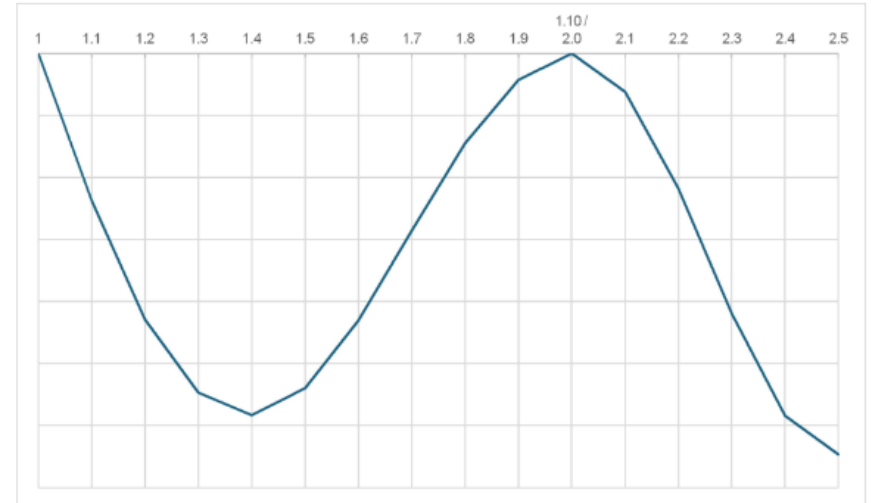

DEFLECTION VERSUS SPAN TENTH POINT, SYMMETRIC ABOUT L/2 SPAN 2

All Girders

Deflection Assumptions

"Steel Only" = self weight of girders

"Slab" = deflection due to user-input non composite uniform dead load (slab, haunch, allowance for bracing)

"Barrier Rails" = deflection due to barrier rail loading distributed evenly to exterior and first interior girder.

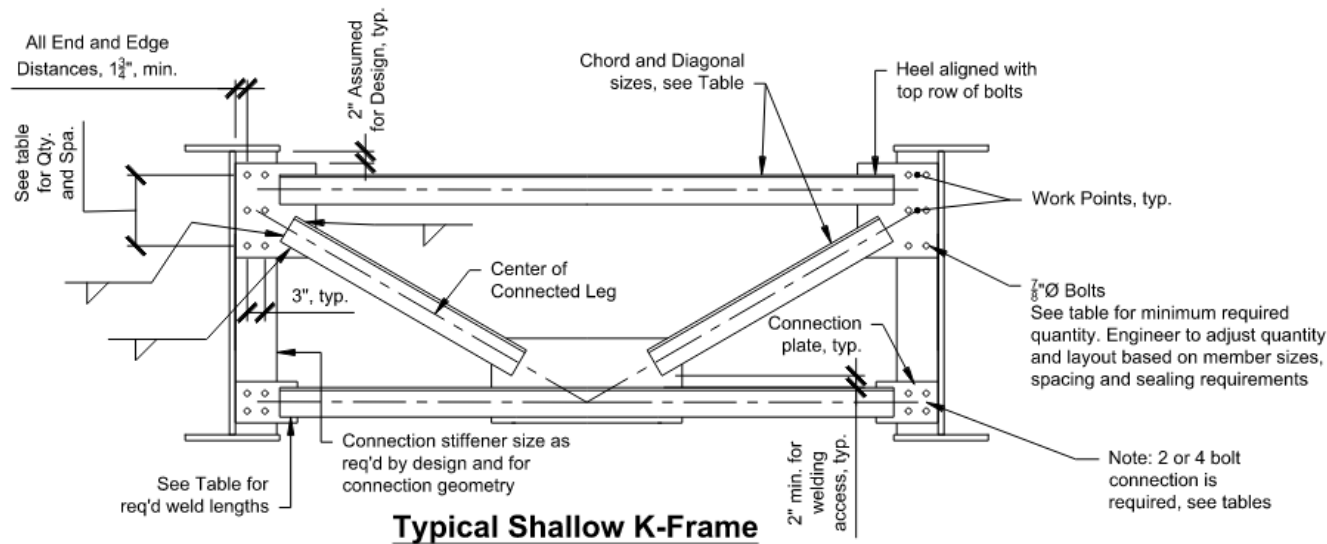
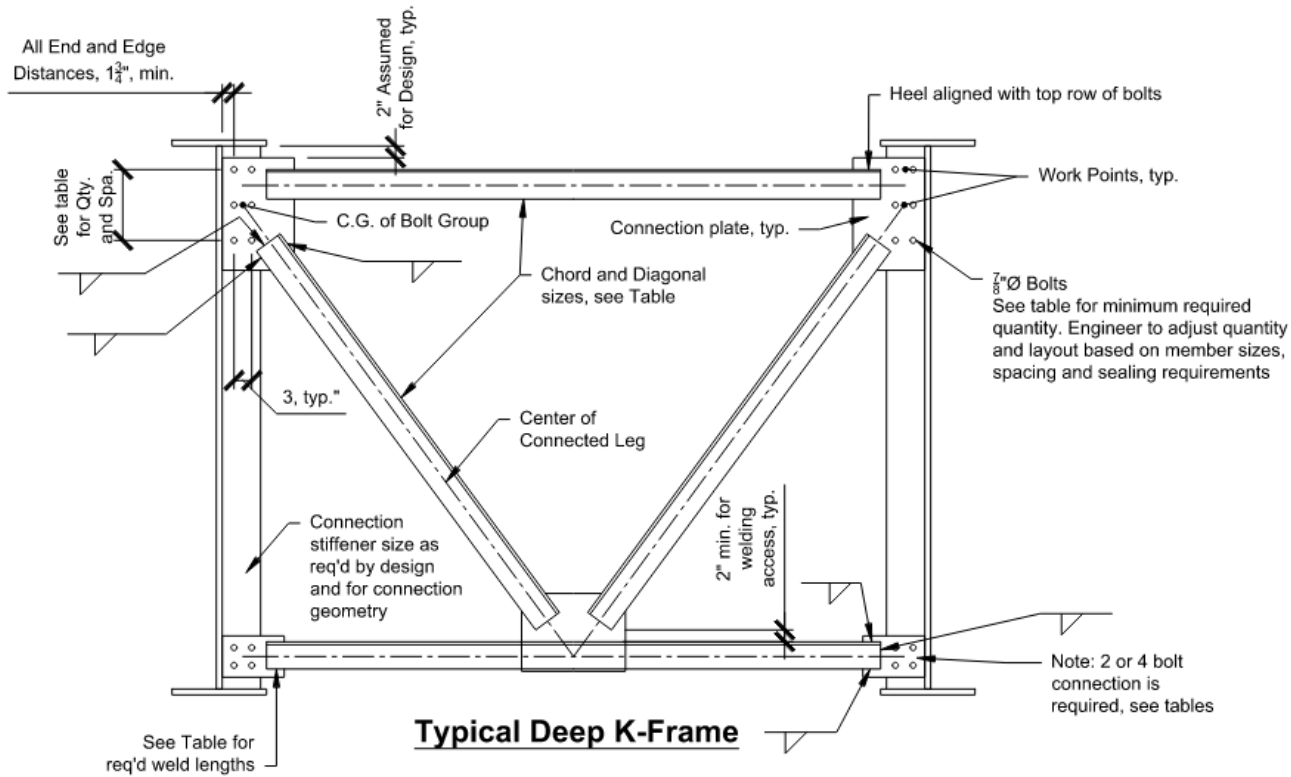

CROSS-FRAME DETAILS				
Beam Spacing, ft.	Span, ft. End-Int.-End	Type	Chord	Diagonal
8	117-150-117 through 164-210-164	K-Frame	L5X5X3/8	L5X5X3/8
	176-225-176 through 234-300-234	X-Frame	L5X5X3/8	L6x6x3/8
10	117-150-117 through 199-255-199	K-Frame	L5X5X3/8	L5X5X3/8
	211-270-211 through 234-300-234	X-Frame	L5X5X3/8	L6X6X3/8
12	All spans	K-Frame	L6X6X3/8	L5X5X3/8
14	141-180-141 through 234-300-234	K-Frame	L8X6X1/2	L5X5X3/8

CROSS-FRAME WELD DETAILS		
Angle Size	Toe Length	Heel Length
L5x5x3/8	2 in. min.	4 in.
L6x6x3/8	See notes regarding toe weld length	4 in.
L8x6x1/2		4

CROSS-FRAME BOLTED CONNECTION DETAILS					
Beam Spacing, ft.	Type	Top Connection		Bottom Connection	
		Total Num Bolts	Vertical Spacing	Total Num Bolts	Vertical Spacing
8	K-Frame	6	6 in.	2	3 in.
	X-Frame	6	6 in.	6	6 in.
10	K-Frame	6	6 in.	2	3 in.
	X-Frame	6	6 in.	6	6 in.
12	K-Frame	6	6 in.	2	3 in.
14	K-Frame	8	4.75	4	4.75

Notes:
1. For general notes, see **Cross-Frame & Diaphragm Details 1.**



CROSS-FRAME & DIAPHRAGM DETAILS 2

Issued January 2025
Revision 0

Sheet 23 of 32

CROSS-FRAME DETAILS				
Beam Spacing, ft.	Span, ft. End-Int.-End	Type	Chord	Diagonal
8	117-150-117 through 164-210-164	K-Frame	L5X5X3/8	L5X5X3/8
	176-225-176 through 234-300-234	X-Frame	L5X5X3/8	L6x6x3/8
10	117-150-117 through 199-255-199	K-Frame	L5X5X3/8	L5X5X3/8
	211-270-211 through 234-300-234	X-Frame	L5X5X3/8	L6X6X3/8
12	All spans	K-Frame	L6X6X3/8	L5X5X3/8
14	141-180-141 through 234-300-234	K-Frame	L8X6X1/2	L5X5X3/8

CROSS-FRAME DETAILS				
Beam Spacing, ft.	Span, ft. End-Int.-End	Type	Chord	Diagonal
8	117-150-117 through 164-210-164	K-Frame	L5X5X3/8	L5X5X3/8
	176-225-176 through 234-300-234	X-Frame	L5X5X3/8	L6x6x3/8
10	117-150-117 through 199-255-199	K-Frame	L5X5X3/8	L5X5X3/8
	211-270-211 through	X-Frame	L5X5X3/8	L6X6X3/8

with top row of bolts

Work Points, typ.

7/8" Ø Bolts

See table for minimum required quantity. Engineer to adjust quantity and layout based on member sizes and spacing.

CROSS-FRAME WELD DETAILS		
Angle Size	Toe Length	Heel Length
L5x5x3/8	2 in. min.	4 in.
L6x6x3/8	See notes regarding toe weld length	4 in.
L8x6x1/2		4

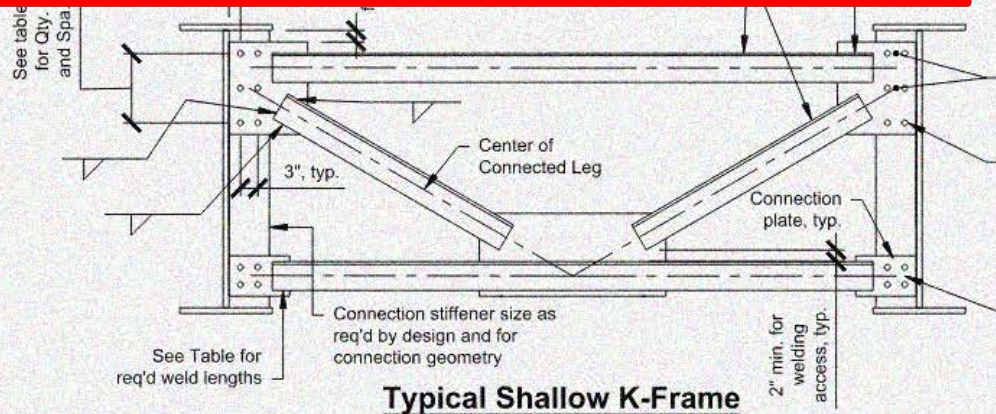

CROSS-FRAME BOLTED CONNECTION DETAILS					
Beam Spacing, ft.	Type	Top Connection		Bottom Connection	
		Total Num Bolts	Vertical Spacing	Total Num Bolts	Vertical Spacing
8	K-Frame	6	6 in.	2	3 in.
	X-Frame	6	6 in.	6	6 in.
10	K-Frame	6	6 in.	2	3 in.
	X-Frame	6	6 in.	6	6 in.
12	K-Frame	6	6 in.	2	3 in.
14	K-Frame	8	4.75	4	4.75

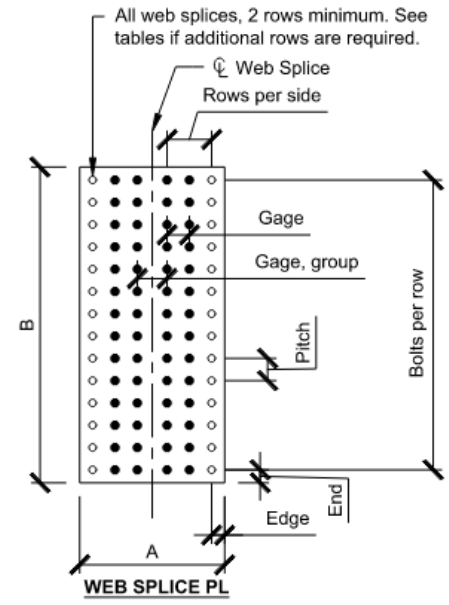
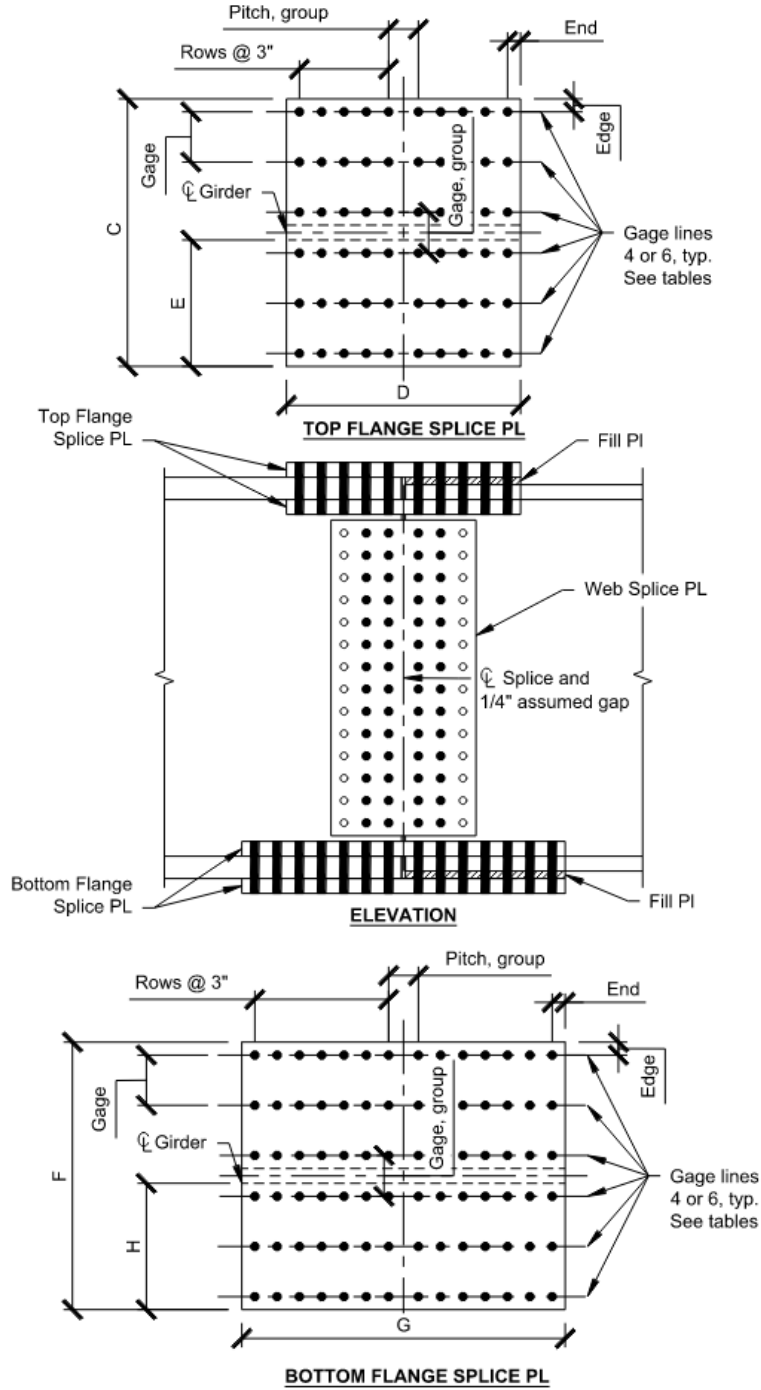

NOTES:

All bolted field splices designed using NSBA Splice Version 03_15. Design assumptions listed below. For bolt quantity and plate dimensions, see Sheets **Bolted Field Splice Dimensions 1 - 4**.

1. Bolts F3125 Grade A325, Type 3 weathering, 1 in. diameter in 1.125 in. diameter holes. All plates A709 Grade 50W.
2. Threads excluded from flange shear planes. Threads included in web shear planes.
3. Class B surface condition for slip resistance.
4. For continuous spans in which "Splice 0" is used to control the field section lengths, a large moment must be carried by the web (AASHTO LRFD 6.13.6.1.3c). If the combined tension due to the bottom flange force plus the web force, H_w , exceeds the compression capacity of the slab, these splices are designed as noncomposite and noted in the design tables.
5. Top and bottom flange bolt group dimension, "Gage, Group" exceeds the 7 in. maximum spacing for sealing for some splices (AASHTO LRFD 6.13.2.6.2). This is due to girder tension flange net section requirements at the splice, the choice of 1 in. diameter bolts, and enforced symmetry requirements for the inner flange splice plates. The engineer may choose to accept the proposed designs, or redesign the splice. Solutions could include using asymmetric inner plates, staggered bolts, or smaller diameter fasteners. If additional and smaller diameter bolts are used to decrease the "Gage, Group" dimension, check the net section. See AASHTO LRFD 6.10.1.8.

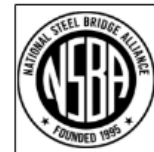

BOLTED FIELD SPLICE LAYOUT

Issued January 2025
Revision 0

Sheet 25 of 32

Spacing-Span	Web Splice Plates				Top Flange Plates, Outer				Top Flange Plates, Inner, 2 req'd.			Bottom Flange Plates, Outer				Bottom Flange Plates, Inner, 2 req'd.			Web Bolts					Top Flange Bolts					Bottom Flange Bolts					Composite Note
	Width, A	Length, B	Thk.	Edge / End Distance	Width, C	Length, D	Thk.	Edge / End Distance	Width, E	Length, D	Thk.	Width, F	Length, G	Thk.	Edge / End Distance	Width, H	Length, G	Thk.	Bolts per Row	Rows per Side	Pitch	Gage	Gage, group	Num Rows Ea Side	Pitch, group	Gage Lines	Gage	Gage, group	Num Rows Ea Side	Pitch, group	Gage Lines	Gage	Gage, group	
12-117-150 Splice 1	12.25	49	0.5	1.5 / 1.5	16	18.25	0.625	1.5 / 1.5	7	18.25	0.625	22	30.25	0.75	1.5 / 1.5	10	30.25	0.75	9	2	5.75	3	3.25	3	3.25	4	4	5	5	3.25	4	7	5	Composite
12-117-150 Splice 2	12.25	49	0.5	1.5 / 1.5	16	18.25	0.625	1.5 / 1.5	7	18.25	0.625	22	30.25	0.75	1.5 / 1.5	10	30.25	0.75	9	2	5.75	3	3.25	3	3.25	4	4	5	5	3.25	4	7	5	Composite
12-129-165 Splice 1	12.25	56.75	0.5	1.5 / 1.5	16	18.25	0.625	1.5 / 1.5	7	18.25	0.625	22	30.25	0.75	1.5 / 1.5	10	30.25	0.75	11	2	5.375	3	3.25	3	3.25	4	4	5	5	3.25	4	7	5	Composite
12-129-165 Splice 2	12.25	56.75	0.5	1.5 / 1.5	16	18.25	0.625	1.5 / 1.5	7	18.25	0.625	22	24.25	0.75	1.5 / 1.5	10	24.25	0.75	11	2	5.375	3	3.25	3	3.25	4	4	5	4	3.25	4	7	5	Composite
12-141-180 Splice 1	12.25	60.5	0.5	1.5 / 1.5	18	18.25	0.625	1.5 / 1.5	8	18.25	0.625	22	30.25	0.875	1.5 / 1.5	10	30.25	0.875	11	2	5.75	3	3.25	3	3.25	4	5	5	5	3.25	4	7	5	Composite
12-141-180 Splice 2	12.25	60.5	0.5	1.5 / 1.5	16	18.25	0.625	1.5 / 1.5	7	18.25	0.625	22	24.25	0.875	1.5 / 1.5	10	24.25	0.875	11	2	5.75	3	3.25	3	3.25	4	4	5	4	3.25	4	7	5	Composite
12-153-195 Splice 1	12.25	69	0.5	1.5 / 1.5	18	18.25	0.625	1.5 / 1.5	8	18.25	0.625	24	18.25	0.75	1.5 / 1.5	11	18.25	0.75	13	2	5.5	3	3.25	3	3.25	4	5	5	3	3.25	6	4	5	Composite
12-153-195 Splice 2	12.25	69	0.5	1.5 / 1.5	18	18.25	0.625	1.5 / 1.5	8	18.25	0.625	24	18.25	0.75	1.5 / 1.5	11	18.25	0.75	13	2	5.5	3	3.25	3	3.25	4	5	5	3	3.25	6	4	5	Composite
12-164-210 Splice 1	12.25	72	0.5	1.5 / 1.5	18	18.25	0.625	1.5 / 1.5	8	18.25	0.625	24	18.25	0.75	1.5 / 1.5	11	18.25	0.75	13	2	5.75	3	3.25	3	3.25	4	5	5	3	3.25	6	4	5	Composite
12-164-210 Splice 2	12.25	72	0.5	1.5 / 1.5	18	18.25	0.625	1.5 / 1.5	8	18.25	0.625	22	18.25	0.875	1.5 / 1.5	10	18.25	0.875	13	2	5.75	3	3.25	3	3.25	4	5	5	3	3.25	6	3.5	5	Composite
12-176-225 Splice 1	12.25	76.125	0.5	1.5 / 1.5	18	24.25	0.75	1.5 / 1.5	8	24.25	0.75	22	18.25	1	1.5 / 1.5	10	18.25	1	14	2	5.625	3	3.25	4	3.25	4	5	5	3	3.25	6	3.5	5	Composite
12-176-225 Splice 2	12.25	76.125	0.5	1.5 / 1.5	18	18.25	0.75	1.5 / 1.5	8	18.25	0.75	22	18.25	0.875	1.5 / 1.5	10	18.25	0.875	14	2	5.625	3	3.25	3	3.25	4	5	5	3	3.25	6	3.5	5	Composite
12-188-240 Splice 1	12.25	81.75	0.5	1.5 / 1.5	20	24.25	0.75	1.5 / 1.5	9	24.25	0.75	24	18.25	0.75	1.5 / 1.5	11	18.25	0.75	15	2	5.625	3	3.25	4	3.25	4	6	5	3	3.25	6	4	5	Composite
12-188-240 Splice 2	12.25	81.75	0.5	1.5 / 1.5	20	24.25	0.75	1.5 / 1.5	9	24.25	0.75	20	18.25	0.75	1.5 / 1.5	9	18.25	0.75	15	2	5.625	3	3.25	4	3.25	4	6	5	3	3.25	6	3	5	Composite
12-199-255 Splice 1	12.25	89.25	0.5	1.5 / 1.5	20	24.25	0.625	1.5 / 1.5	9	24.25	0.625	24	18.25	0.75	1.5 / 1.5	11	18.25	0.75	16	2	5.75	3	3.25	4	3.25	4	6	5	3	3.25	6	4	5	Composite
12-199-255 Splice 2	12.25	89.25	0.5	1.5 / 1.5	20	24.25	0.625	1.5 / 1.5	9	24.25	0.625	24	18.25	0.625	1.5 / 1.5	11	18.25	0.625	16	2	5.75	3	3.25	4	3.25	4	6	5	3	3.25	6	4	5	Composite
12-211-270 Splice 0	12.25	93	0.5	1.5 / 1.5	20	24.25	0.75	1.5 / 1.5	8	24.25	0.75	24	30.25	0.75	1.5 / 1.5	10	30.25	0.75	17	2	5.625	3	3.25	4	3.25	4	5	7	5	3.25	4	7	7	Composite
12-211-270 Splice 1	12.25	93	0.5	1.5 / 1.5	20	30.25	0.75	1.5 / 1.5	9	30.25	0.75	24	24.25	0.75	1.5 / 1.5	11	24.25	0.75	17	2	5.625	3	3.25	5	3.25	4	6	5	4	3.25	6	4	5	Composite
12-211-270 Splice 2	12.25	93	0.5	1.5 / 1.5	20	24.25	0.75	1.5 / 1.5	9	24.25	0.75	24	18.25	0.75	1.5 / 1.5	11	18.25	0.75	17	2	5.625	3	3.25	4	3.25	4	6	5	3	3.25	6	4	5	Composite
12-223-285 Splice 0	12.25	95.25	0.5	1.5 / 1.5	22	30.25	0.75	1.5 / 1.5	9	30.25	0.75	24	30.25	0.75	1.5 / 1.5	10	30.25	0.75	19	2	5.125	3	3.25	5	3.25	4	6	7	5	3.25	4	7	7	Composite
12-223-285 Splice 1	12.25	97	0.5	1.5 / 1.5	22	24.25	0.75	1.5 / 1.5	10	24.25	0.75	24	18.25	0.75	1.5 / 1.5	11	18.25	0.75	17	2	5.875	3	3.25	4	3.25	4	7	5	3	3.25	6	4	5	Composite
12-223-285 Splice 2	12.25	97	0.5	1.5 / 1.5	22	24.25	0.75	1.5 / 1.5	10	24.25	0.75	22	30.25	0.75	1.5 / 1.5	10	30.25	0.75	17	2	5.875	3	3.25	4	3.25	4	7	5	5	3.25	4	7	5	Composite
12-234-300 Splice 0	12.25	102.875	0.5	1.5 / 1.5	24	30.25	0.75	1.5 / 1.5	10	30.25	0.75	24	30.25	0.875	1.5 / 1.5	10	30.25	0.875	18	2	5.875	3	3.25	5	3.25	4	7	7	5	3.25	4	7	7	Composite
12-234-300 Splice 1	12.25	102.875	0.5	1.5 / 1.5	24	18.25	0.75	1.5 / 1.5	11	18.25	0.75	24	18.25	0.875	1.5 / 1.5	11	18.25	0.875	18	2	5.875	3	3.25	3	3.25	6	4	5	3	3.25	6	4	5	Composite
12-234-300 Splice 2	12.25	102.875	0.5	1.5 / 1.5	22	18.25	0.75	1.5 / 1.5	10	18.25	0.75	24	18.25	0.875	1.5 / 1.5	11	18.25	0.875	18	2	5.875	3	3.25	3	3.25	6	3.5	5	3	3.25	6	4	5	Composite

12 FT SPACING - 3 SPAN

NOTES:

- All dimensions / spacing shown in tables in inch units.



BOLTED FIELD SPLICE DIMENSIONS 3

Issued January 2025
Revision 0

Sheet 28 of 32

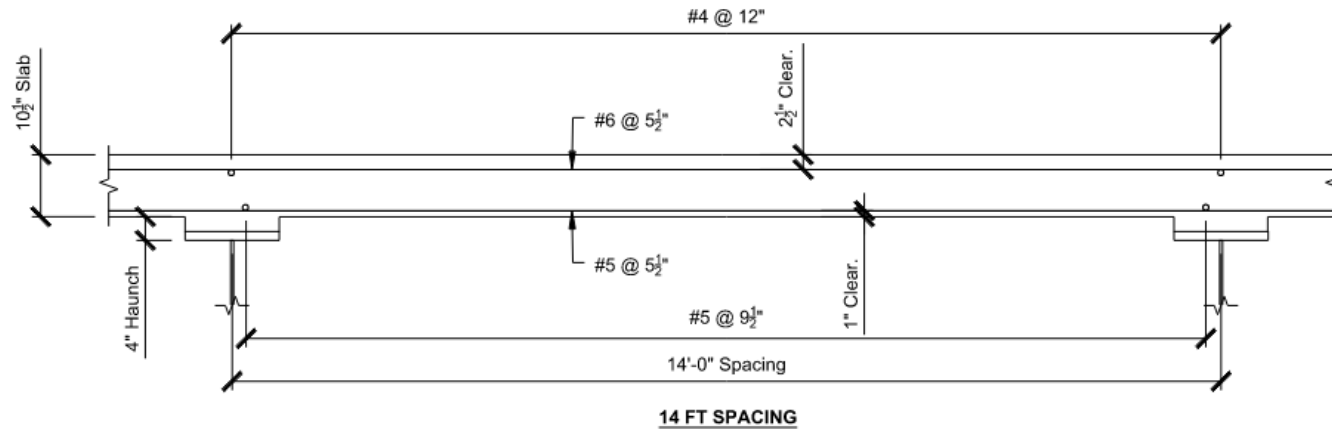
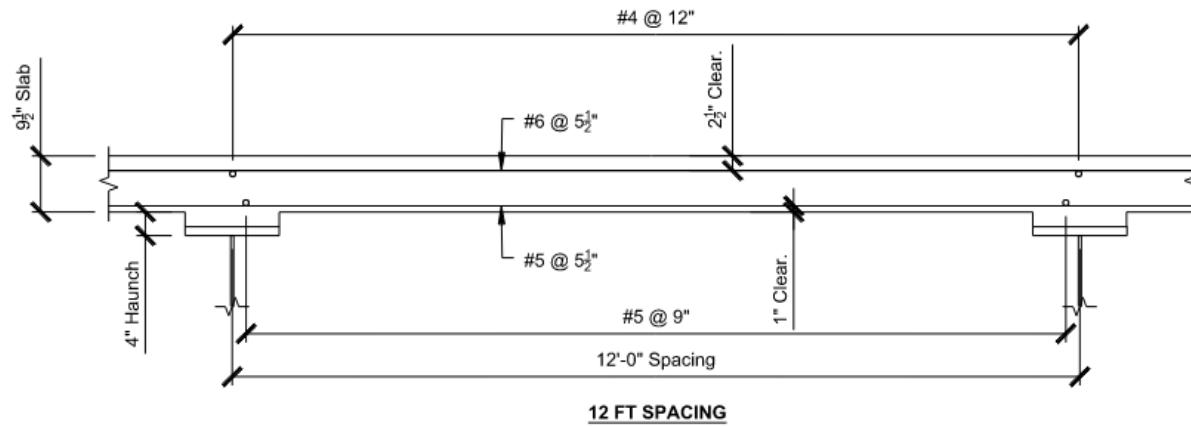
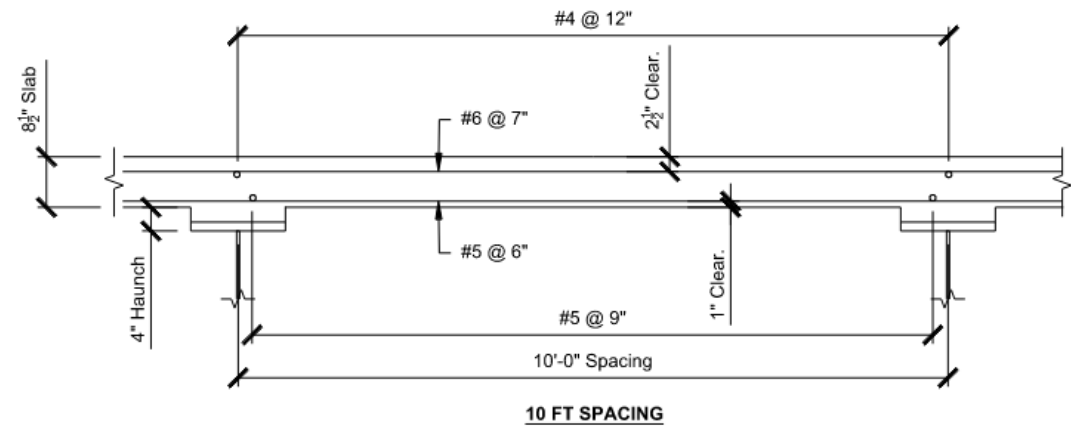
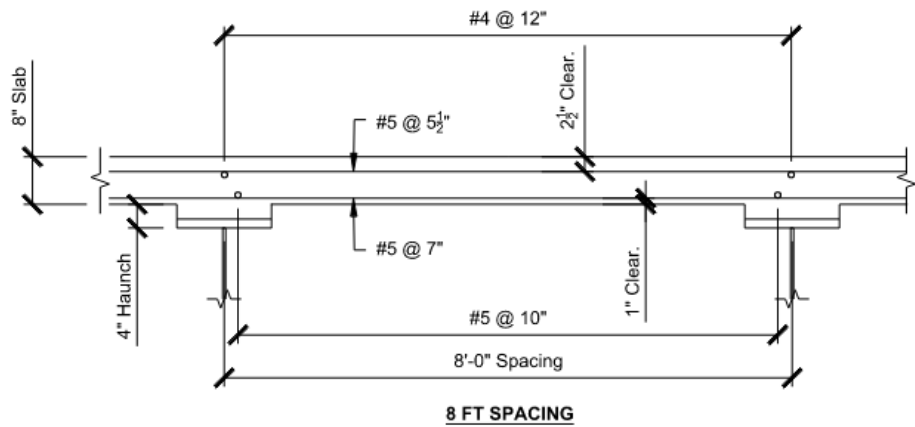

DECK DESIGN NOTES

1. Deck details are representative of slab designs for the beam spacings used in these plans.
2. The gross thickness shown is used for weight calculations. Structural capacity assumes a 1/2 in. loss in deck thickness due to wear.
3. The details on this sheet are for positive moment regions of the span and represent an acceptable transverse and longitudinal reinforcing steel design complying with AASHTO LRFD 9.7.3.
4. The slab thickness, cover, bar sizes and spacing are based on decks designed using the AASHTO equivalent strip method.

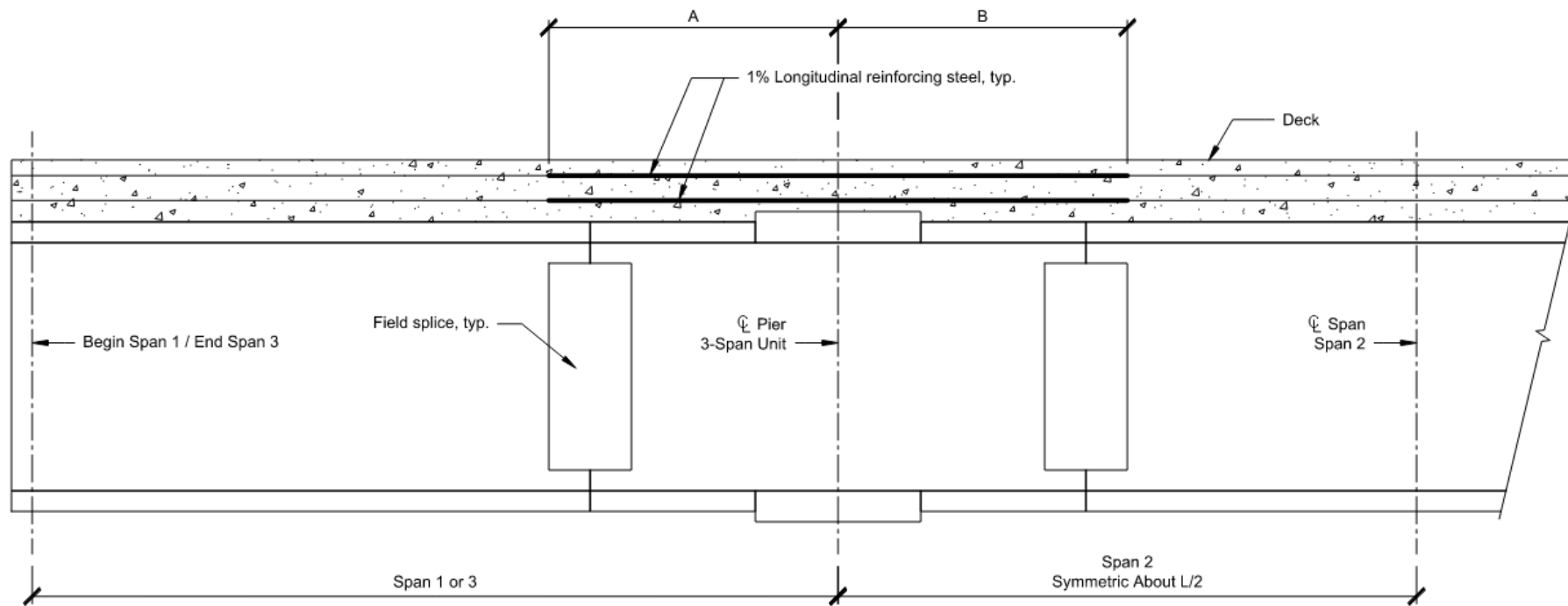

LONGITUDINAL REINFORCING STEEL TERMINATION LIMITS

Notes:

1. Dimension "A" defines the limit of required one percent longitudinal reinforcing steel extending from Pier 1 or 2 into either Span 1 or 3.
2. Dimension "B" defines the limit of required one percent longitudinal reinforcing steel extending from Pier 1 or 2 into Span 2.
3. Dimension "A" and "B" are at a minimum the distance to each field splice or as required by Note (4) below.
4. Longitudinal reinforcing steel is designed to meet the requirements of Service II Limit State, AASHTO LRFD 6.10.1.7 in the completed bridge only. The cutoff locations are approximate and are to be refined in final design.
5. Designer to determine if the factored deck casting and construction loads require this reinforcing steel to be extended.
6. For beam design, the longitudinal reinforcing steel was assumed to be exactly one percent and meeting the preferred two-thirds top mat placement. Sample reinforcing patterns for the positive and negative moment region longitudinal reinforcing steel are provided in the Deck Details, Sheet 30 and 31.

1% Longitudinal Steel, Distances A and B, ft.				
Versus Beam Spacing, ft.				
Span, ft. End-Int.-End	8 ft.	10 ft.	12 ft.	14 ft.
	Length A, B	Length A, B	Length A, B	Length A, B
117-150-117	43 38	38 38	38 38	38 38
129-165-129	49 42	40 40	40 40	40 40
141-180-141	53 45	47 43	43 43	43 43
153-195-153	58 52	54 47	47 47	47 47
164-210-164	61 56	59 51	59 51	56 51
176-225-176	67 61	61 54	59 54	61 54
188-240-188	71 64	70 62	69 58	67 58
199-255-199	73 69	74 67	73 65	72 61
211-270-211	78 70	81 66	78 72	78 67
223-285-223	82 79	83 77	82 73	73 73
234-300-234	86 80	86 80	86 80	78 80

Conclusions

- Modern, cost-effective, and comprehensive standard plans have been developed
- Simple spans from 80 – 300 ft and continuous spans as long as 300 ft are included
- Four unique beam spacings are covered
- Design of the final beams is performed / checked using NSBA LRFD SIMON
- Extensive checking of stability during deck casting, stresses from overhang brackets, and stresses / deflections under wind load are considered
- Many additional design elements are fully designed and detailed including splices, cross-frames, lateral bracing, and shear connectors
- Designs are “near final” and require only the adaptation to specific site requirements that may differ from the standard plans.

Thank You

FRANCESCO M RUSSO, PHD, PE
FOUNDER & PRINCIPAL

215.266.5623

Frank.Russo@RussoStructural.com

www.RussoStructural.com

