



# Steel Bridges: Beyond the Textbook

---

## Webinar 5 – Part 1: Steel Bridge Corrosion Protection Design Strategies – A Designer’s Perspective

June 23, 2026

Brandon Chavel, PhD, PE  
National Steel Bridge Alliance



# Steel Bridge Protection Design Strategies

- Make good design decisions early!
- Resources to be discussed today
  - NSBA Uncoated Weathering Steel Reference Guide
  - AGA Hot-Dip Galvanized Steel Bridge Design Guide
- Choose the right coating protection system for the right application!
- ALWAYS use good detailing practices – ALWAYS!!!



Uncoated  
Weathering Steel  
Reference  
Guide

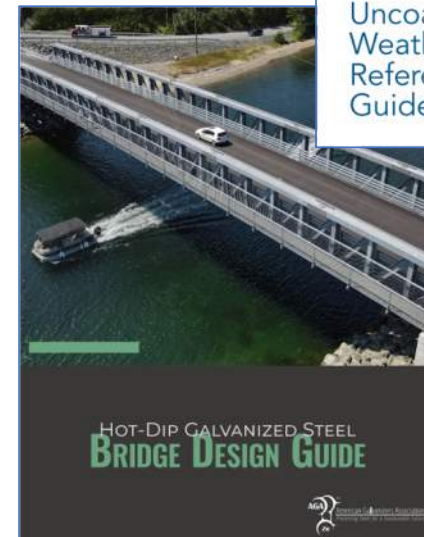

# Uncoated Weathering Steel Reference Guide

## - Guide Content

- Chapter 1 – Introduction
  - Chapter 2 – Design Recommendations
  - Chapter 3 – Fabrication and Construction
  - Chapter 4 – In-Service Inspection
  - Chapter 5 – Maintenance
  - Chapter 6 – Repair and Rehabilitation
- Recommendations given as minimum requirements, and improved performance

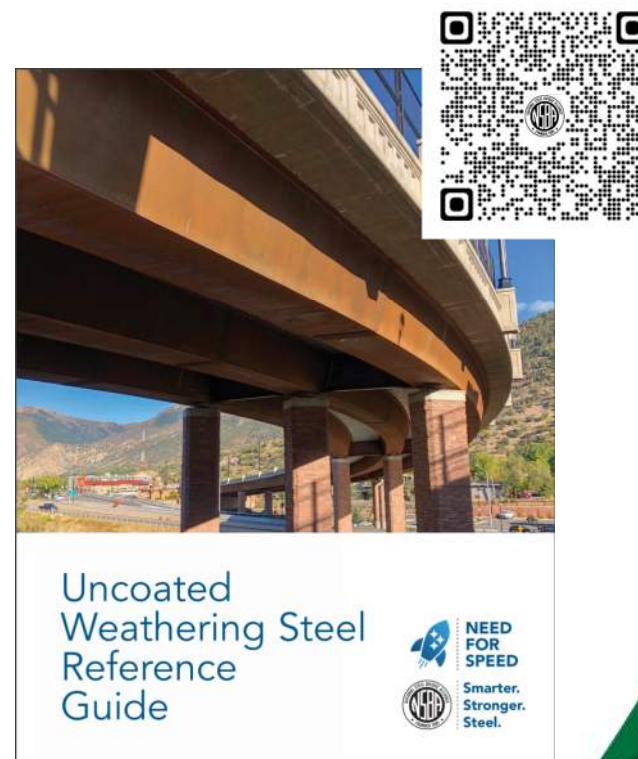

[aisc.org/uwsguide](http://aisc.org/uwsguide)

# Uncoated Weathering Steel Reference Guide

## - Guide Content

- Chapter 1 – Introduction
  - **Chapter 2 – Design Recommendations**
  - Chapter 3 – Fabrication and Construction
  - Chapter 4 – In-Service Inspection
  - **Chapter 5 – Maintenance**
  - Chapter 6 – Repair and Rehabilitation
- Recommendations given as minimum requirements, and improved performance

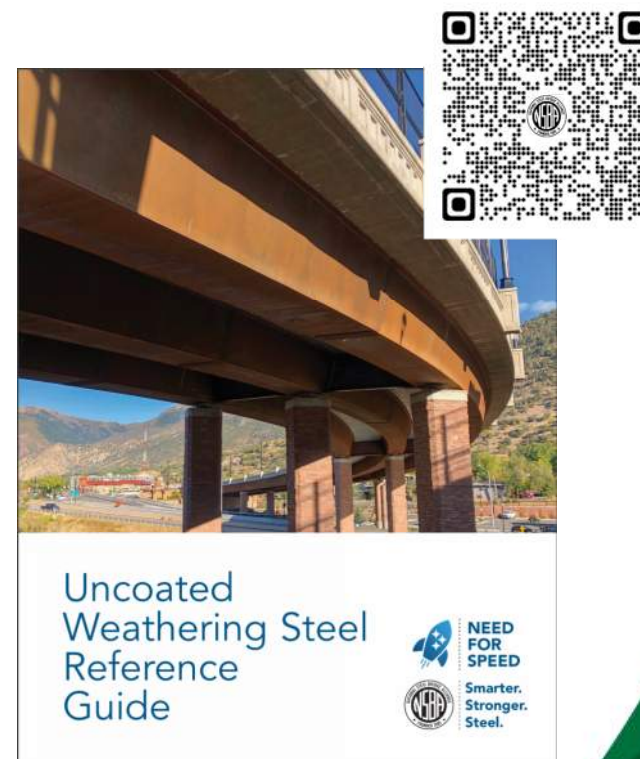

[aisc.org/uwsguide](http://aisc.org/uwsguide)

# Uncoated Weathering Steel Reference Guide

---

- **Design Recommendations**
  - **When to use UWS**
  - **And when to proceed cautiously:**
    - **Macro-environment**
      - **High Time of Wetness environments**
      - **Coastal environments**
    - **Micro-environment**
      - **Deicing salt / tunnel-like situation**
      - **Low vertical clearance over water**
      - **Vegetation / shelter**



Uncoated  
Weathering Steel  
Reference  
Guide



# Uncoated Weathering Steel Reference Guide

## - When to use UWS

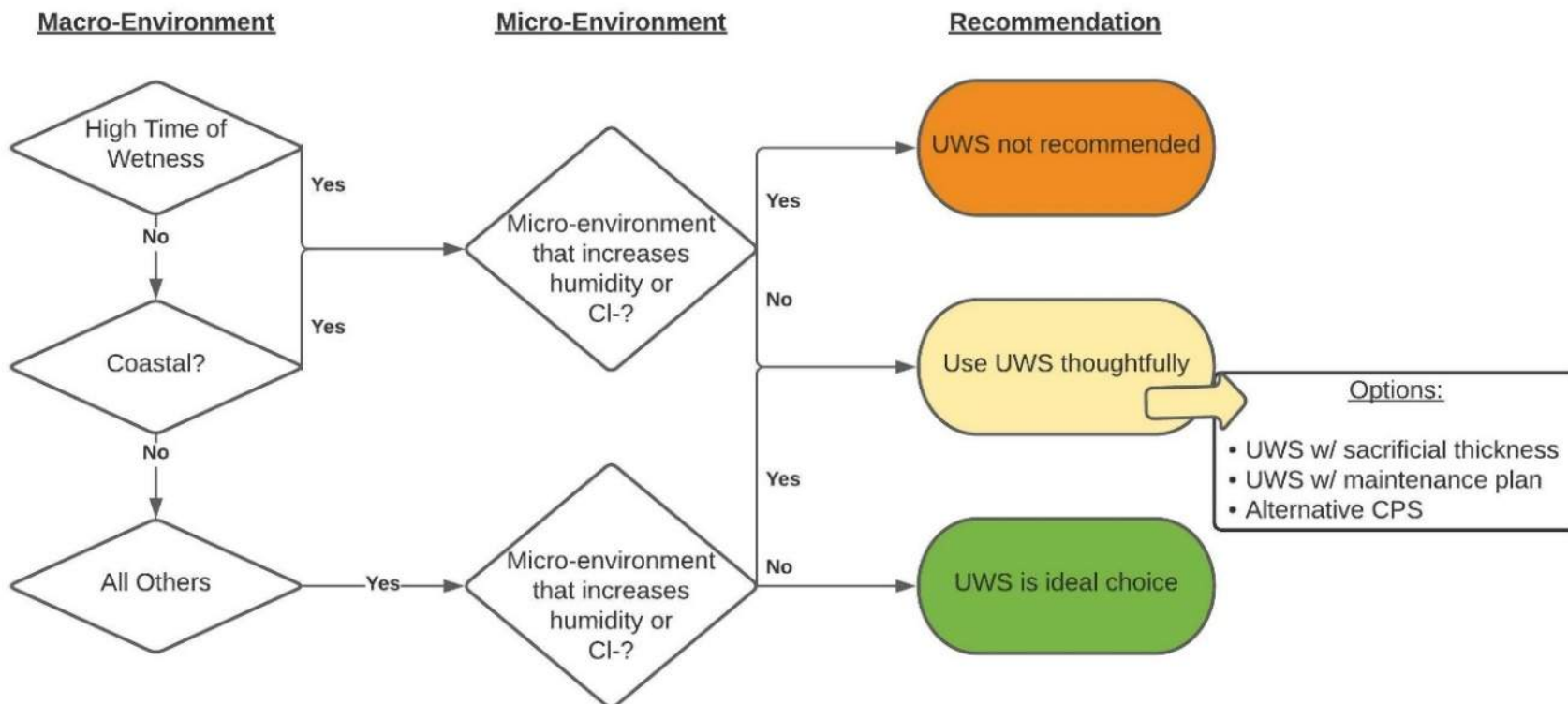

# Uncoated Weathering Steel Reference Guide

## - Tables of UWS Use

Micro-Environment	Macro-Environment		
	All Others	High Time of Wetness	Coastal
All Others	UWS is ideal choice	Use UWS thoughtfully	Use UWS thoughtfully
Highway Crossings with Extreme Salt Use	Use UWS thoughtfully	Use UWS thoughtfully	Use UWS thoughtfully
Water Crossings with Low Vertical Clearance	If minimal vegetation, use UWS thoughtfully; if dense vegetation, UWS not recommended	UWS not recommended	UWS not recommended
Sites with Dense Vegetation or Shelter	UWS is ideal choice, if vegetation can be maintained and, for water crossings, adequate vertical clearance over water provided	UWS not recommended	Depending on severity, UWS not recommended or UWS with sacrificial thickness recommended

# Uncoated Weathering Steel Reference Guide

## - Tables of UWS Use

*Opportunities for other coating systems....  
Galvanizing, Metallizing, or Paint*

Micro-Environment	All Others	High Time of Wetness	Coastal
All Others	UWS is ideal choice	Use UWS thoughtfully	Use UWS thoughtfully
Highway Crossings with Extreme Salt Use	Use UWS thoughtfully	Use UWS thoughtfully	Use UWS thoughtfully
Water Crossings with Low Vertical Clearance	If minimal vegetation, use UWS thoughtfully; if dense vegetation, UWS not recommended	UWS not recommended	UWS not recommended
Sites with Dense Vegetation or Shelter	UWS is ideal choice, if vegetation can be maintained and, for water crossings, adequate vertical clearance over water provided	UWS not recommended	Depending on severity, UWS not recommended or UWS with sacrificial thickness recommended

# Mico-environmental Considerations

---

- Low clearance waterways – current guidance thought to be conservative
- Tunnel-like environments
  - Understanding is evolving\*
- Heavy deicing salts + high traffic counts
- Dense vegetation around superstructure

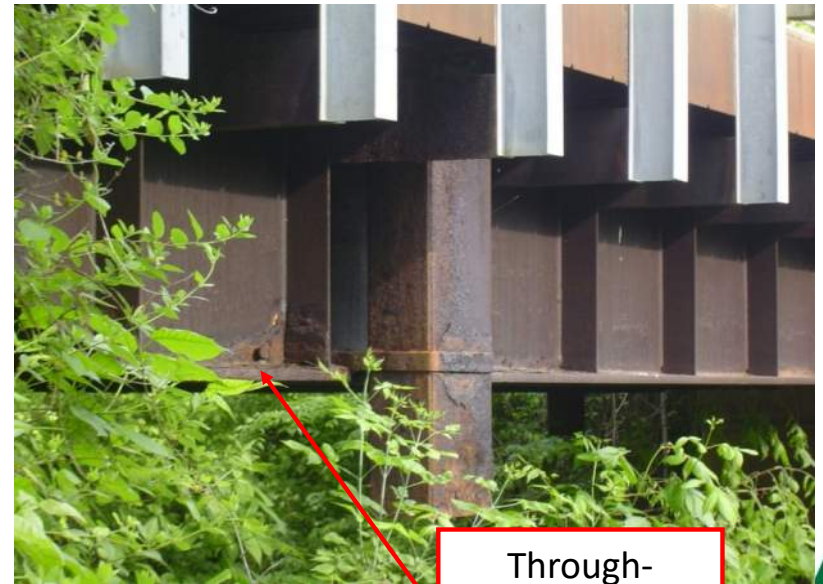

Through-  
thickness section  
loss

# Design Recommendations

- Eliminate joints wherever possible!
- Consider:
  - Integral abutment
  - Semi-integral abutments
  - Placing joints behind the back wall
  - Link slabs
  - others



Uncoated  
Weathering Steel  
Reference  
Guide



NSBA  
National Steel  
Bridge Alliance

Image credit: NSBA

# Design Recommendations

- Eliminate joints wherever possible!
- Consider:
  - Integral abutment
  - Semi-integral abutments
  - Placing joints behind the back wall
  - Link slabs
  - others
- Attention needs to be paid to the drainage system
- Experience is clear – water directly discharging on steel (coated or uncoated) is bad!

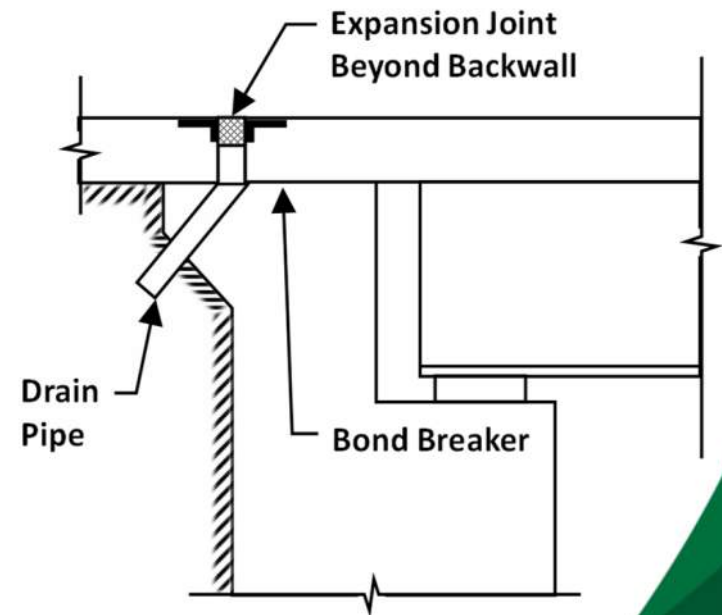

Uncoated  
Weathering Steel  
Reference  
Guide



# Design Recommendations

- Need an expansion joint?
- Virginia Abutments

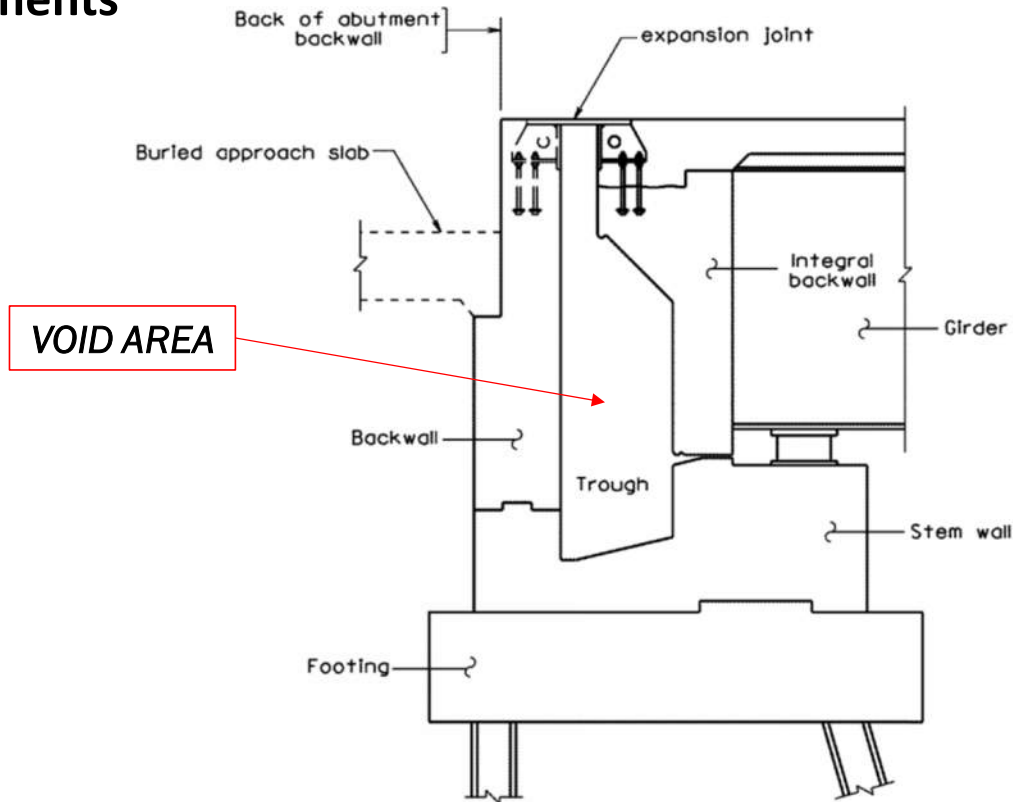

TABLE OF CONTENTS – ABUTMENTS		
CHAPTER 17		
FILE NO.	TITLE	DATE
<b>TABLE OF CONTENTS AND INTRODUCTION</b>		
17.TOC-1	Table of Contents - Chapter 17	30Apr2028
17.TOC-2	Table of Contents - Chapter 17	31Oct2025
17.TOC-3	Table of Contents - Chapter 17	30Apr2025
17.TOC-4	Table of Contents - Chapter 17	31Oct2025
17.TOC-5	Table of Contents - Chapter 17	31Oct2025
17.TOC-6	Table of Contents - Chapter 17	30Apr2026
17.TOC-7	Table of Contents - Chapter 17	30Apr2026
17.TOC-8	Table of Contents - Chapter 17	30Apr2026
17.00-1	Introduction - Chapter 17	30Apr2026
<b>GENERAL INFORMATION AND SELECTION CRITERIA</b>		
17.01-1	Abutment Types	28Apr2022
17.01-2	Abutment Types	30Apr2020
17.01-3	Abutment Types	30Apr2019
17.01-4	Abutment Types	30Apr2026
17.01-5	Abutment Types	30Apr2026
17.01-6	Abutment Types	30Apr2019
17.01-7	Use of MSE Walls and GRS Technology	31Oct2025
17.01-8	Supporting Abutment Spread Footings on MSE Walls	30Apr2026
17.01-9	Abutment Protection and Miscellaneous Requirements	30Apr2025
17.01-10	General Terminology	30Apr2019
17.01-11	Abutment Type Selection Criteria	30Apr2026
17.01-12	Abutment Type Selection Criteria	30Apr2026
17.01-13	Abutment Type Selection Criteria	30Apr2019
17.01-14	Abutment Type Selection Criteria	30Apr2019
17.01-15	Abutment Type Selection Criteria	30Apr2019
17.01-16	Abutment Type Selection Algorithm	30Apr2026
17.01-17	General Guidelines and Requirements for Jointless Abutments	31Oct2025
17.01-18	General Guidelines and Requirements for Jointless Abutments	30Apr2024
17.01-19	General Guidelines and Requirements for Jointless Abutments	30Apr2024
17.01-20	General Guidelines and Requirements for Jointless Abutments	30Apr2019
<b>GENERAL DESIGN REQUIREMENTS</b>		
17.02-1	General Information	29Oct2021
17.02-2	General Information	18May2016
17.02-3	Geotechnical Design Data Tables	30Oct2020
17.02-4	Architectural Treatment for Abutments	31Oct2018
* Indicates 11 x 17 sheet; all others are 8 1/2 x 11		
<b>ABUTMENTS</b>		
<b>TABLE OF CONTENTS – CHAPTER 17</b>		
		PART 2
		DATE: 30Apr2028
		SHEET 1 of 8
		FILE NO: 17.TOC-1

# Details to Avoid Corrosion

---

- Trapped debris retains moisture
- UWS: continuous moisture prevents patina formation
- Coated Steel: constant wetness and trapping of corrosive materials leads to issues



# Drainage on the Girders

## - Stiffener Clips

- The larger the clip, the better for drainage control
- Many states use 2" clips
- 3" may better to avoid clogging with debris

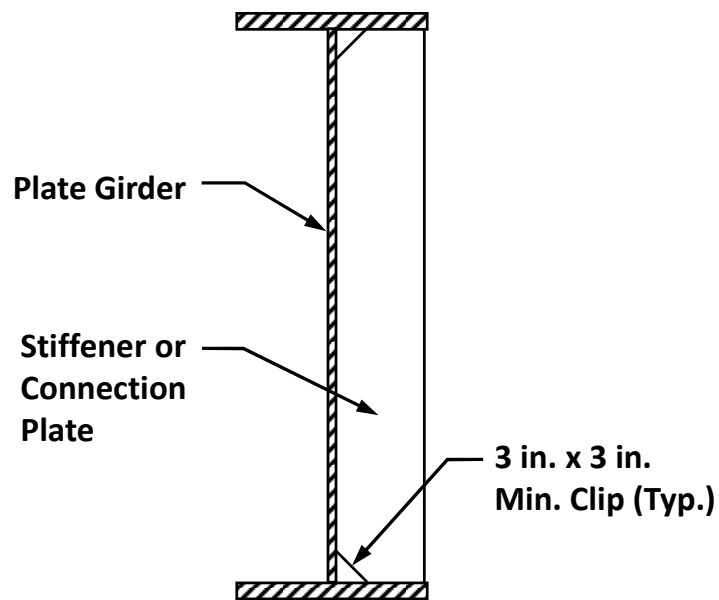

# Tactical Coating

---

- Coating beam ends near open joints is a common practice that has proven to be successful
- Beam ends encased in concrete should typically be coated
  - condensation and capillary action



# Drainage Control on UWS Bridges

## - Drip Bars

- Water flowing down flanges can collect and cause damage, staining
- Drip bars are one way of controlling this drainage
- Welded, or bonded with epoxy

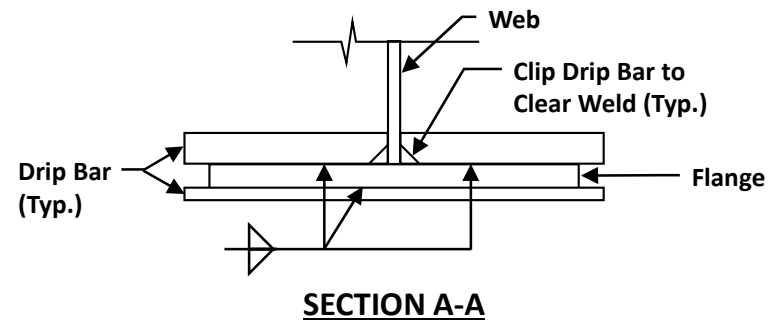
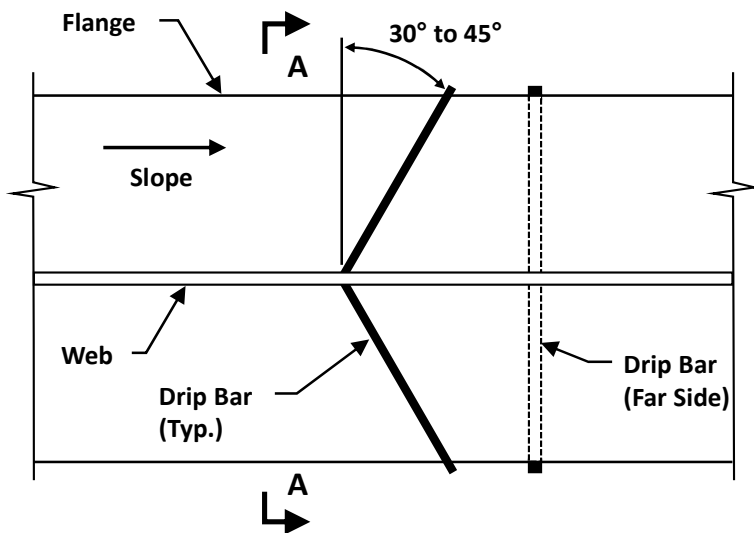

# Drainage Details

## - Drainage Details to try to avoid

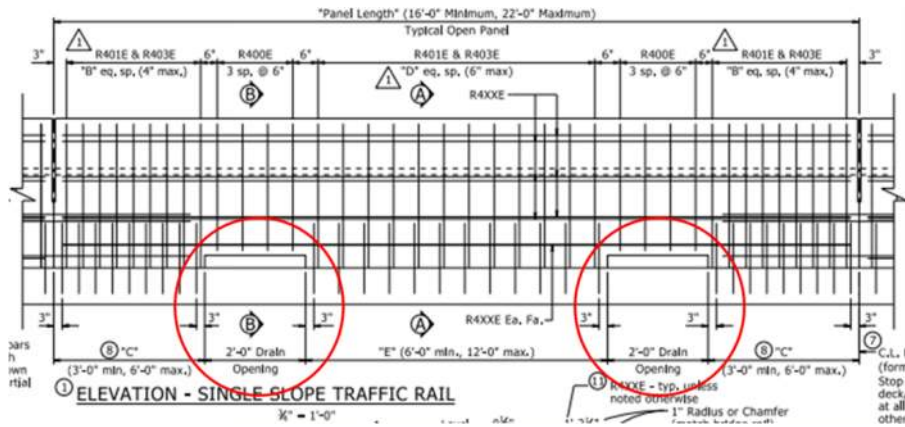

Drainage through the barrier

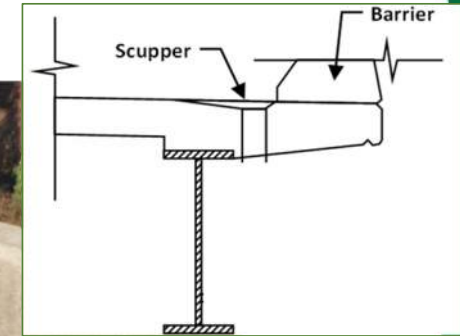

Drainage through the deck only  
no downspout

Image credit: Google Maps

# Drainage Details

## - Preferred Drainage Details

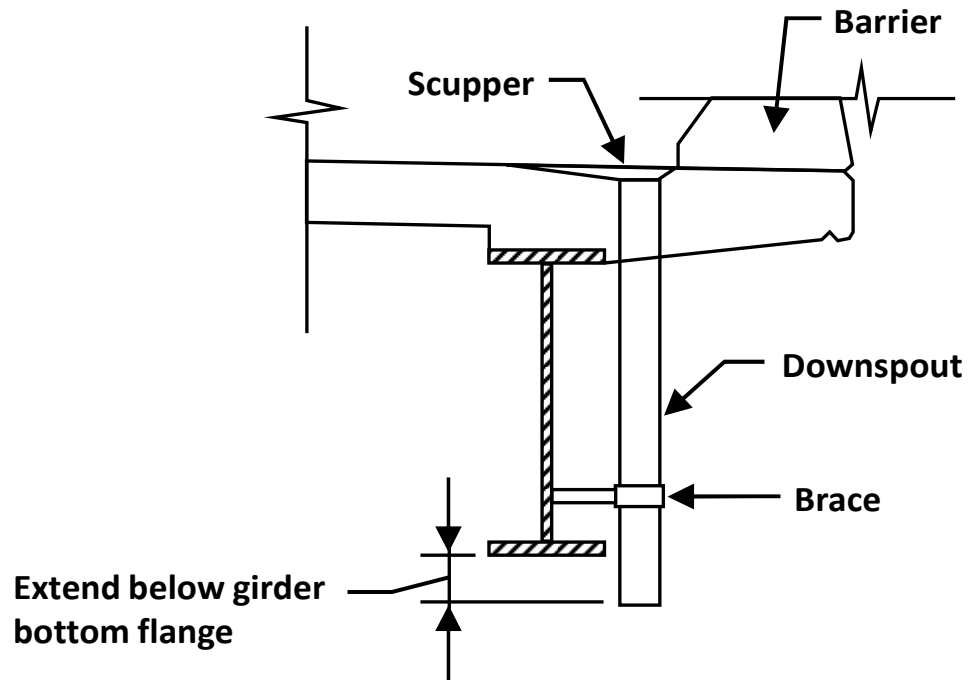

**Downspouts**

# Drainage Details

---

- Closed Drainage System



# Ohio DOT's take on UWS and "tunnel like"

- **ODOT BDM 308.2.2.1.d**
  - UWS is primary system
  - Use a coating system when **ALL** of these are met:
    - A. Vertical clearance is 20-ft or less
    - B. ADT is 50,000 or larger
    - C. ADTT is 20% or more
  - Tunnel like, when **ALL** these are met:
    - A. Vertical clearance is 20-ft or less
    - B. Bridges over interstates or four lane divided highways
    - C. ADTT = 10% or more under the bridge
    - D. Posted speed limit under the bridge is 55 mph or greater

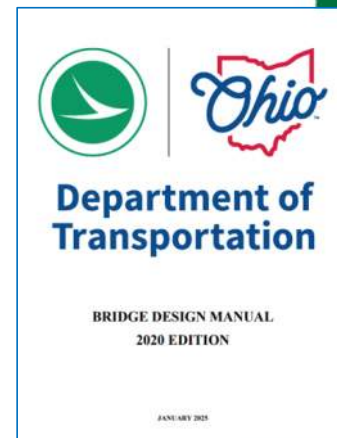

# Ohio DOT's take on UWS and "tunnel like"



- ODOT BDM 308.2.2.1.d
  - When "Tunnel like" – coat fascia girder

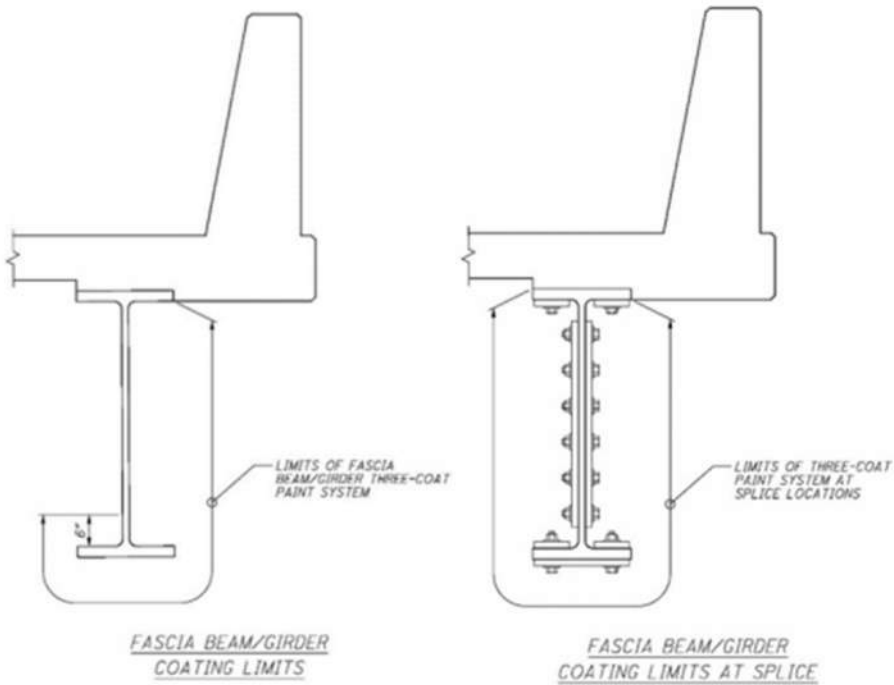

Figure 308-1

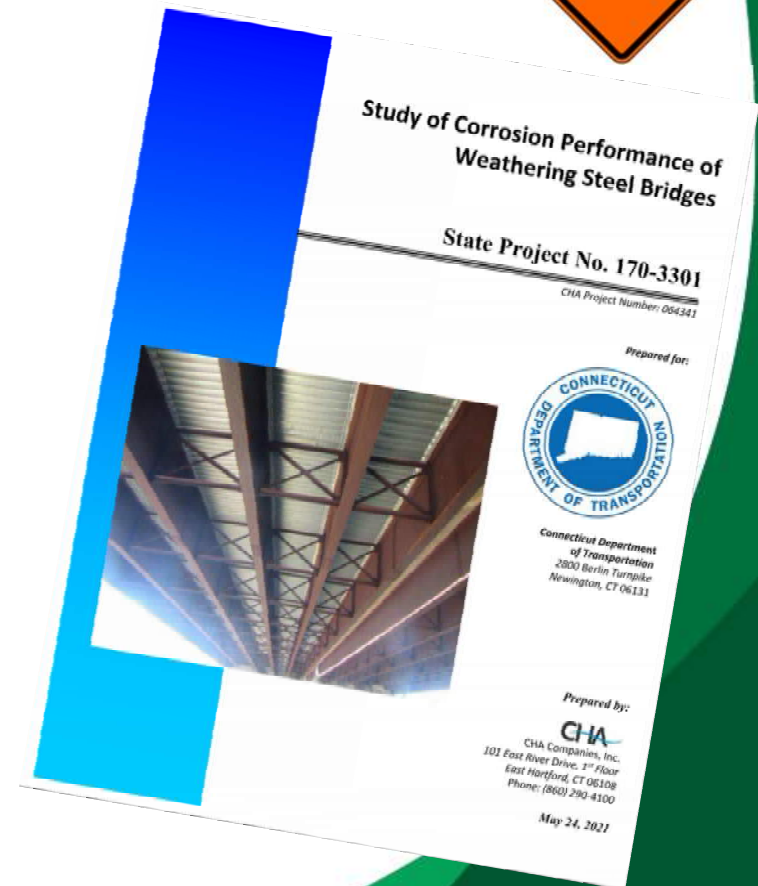

Image credit: Google Maps

# Connecticut DOT Study

## - UWS Study

- Considered 138 UWS bridges
- Bridges with older details have some issues
  - Expansion joint leaks
  - Average section loss of 0.093", or greater
- Structures with newer details performing well
  - No Expansion Joints
    - Integral Abutments
    - Deck over backwall
  - Girder ends coated
- General take away:
  - Issues result from leaky expansion joints and not so much salt spray from below



# Maintenance Practices

---

- Joint sealing
- Drainage system clearing
- Girder washing



# Design and Detail Considerations for Galvanizing

## - Guide Content

- Site/Application Specific Design
- Structural Design
- Detailing
- Fabrication and Construction
- HDG Appearance
- In-Service Inspection Recommendations
- Maintenance & Preservation

- <https://galvanizeit.org/education-and-resources/publications/hot-dip-galvanized-steel-bridge-design-guide>

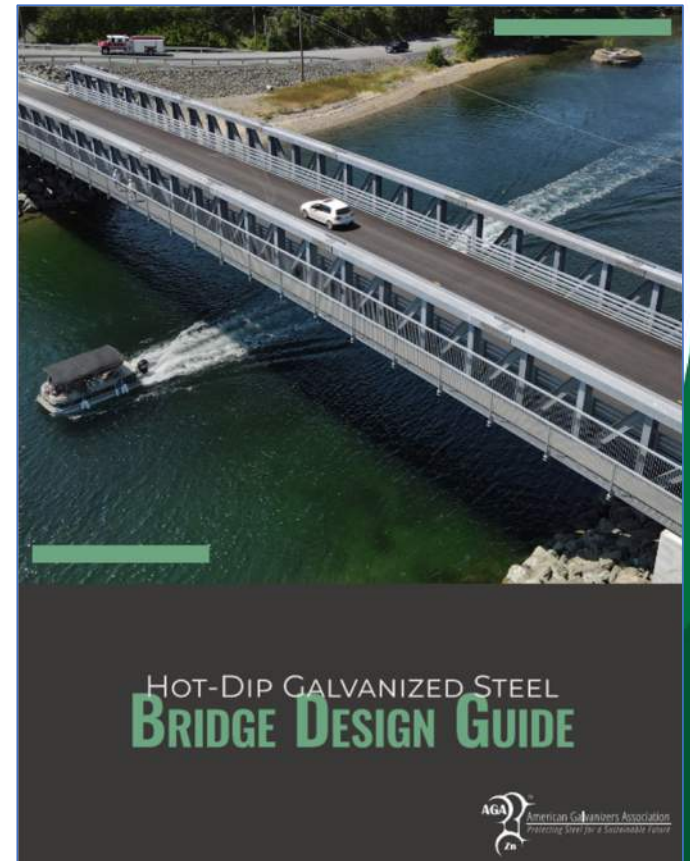

# Design and Detail Considerations for Galvanizing

## - Guide Content

- Site/Application Specific Design
- Structural Design
- **Detailing**
- Fabrication and Construction
- HDG Appearance
- In-Service Inspection Recommendations
- Maintenance & Preservation

- <https://galvanizeit.org/education-and-resources/publications/hot-dip-galvanized-steel-bridge-design-guide>

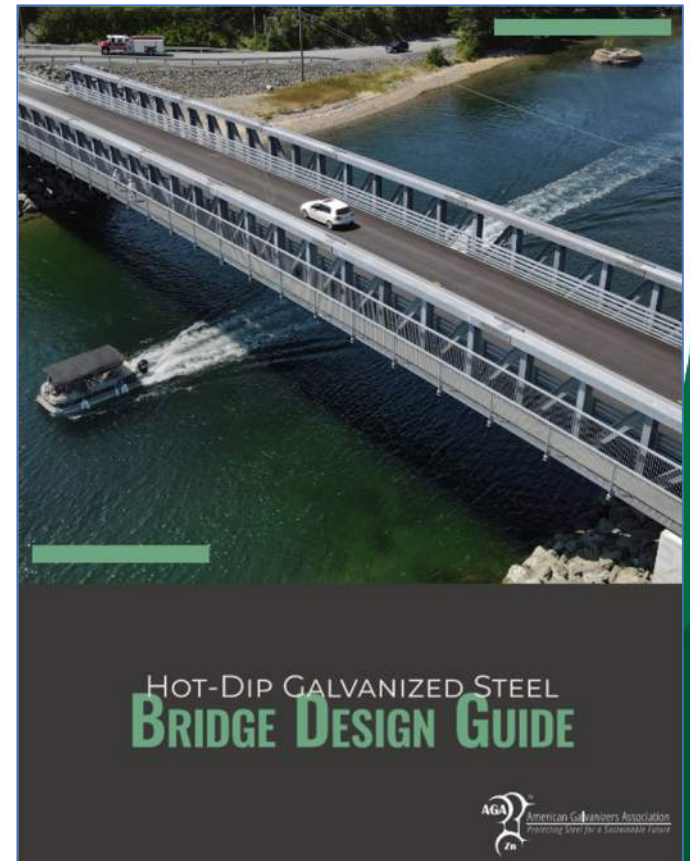

# Design and Detail Considerations for Galvanizing

## - Size Considerations

- Galvanizing kettles 50ft to 60ft, generally
- Use AGA's Galvanizer Locator
  - <https://galvanizeit.org/about-aga/galvanizer-locations>
- Longer than 60ft – Progressive Dip up to certain dimensions
- Use AGA's Progressive Dip Calculator/Charts
  - <https://galvanizeit.org/knowledgebase/article/progressive-dip-calculator>
  - <https://galvanizeit.org/knowledgebase/article/progressive-dip-charts>
- Be mindful of girder depth and weight
  - Crane capacity at a Galvanizer

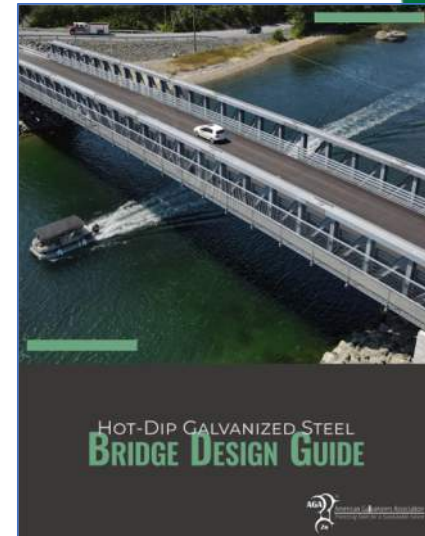
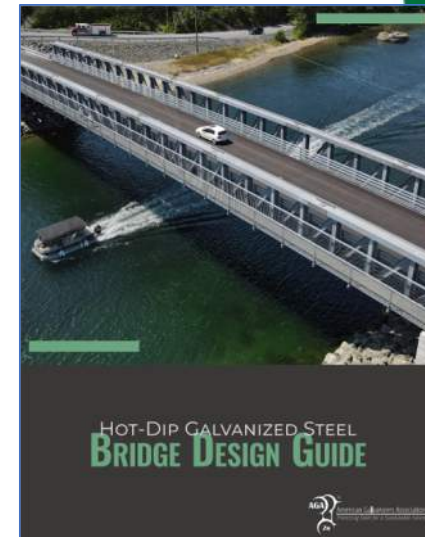

Image credit: DeLong's, Inc.

# Design and Detail Considerations for Galvanizing

---

- **Avoid Distortion – Fabricated welded girders**
  - Flange thickness to web thickness ratio should be no more than 3 to 1
  - Recommended to specify that girders be air cooled after hot-dip galvanizing, and not water quenched, to minimize additional stress from the cooling cycle
  - For cambered girders, recommend that they be laid on the strong axis and supported with as many blocks as possible
    - Prevent sagging or bowing



# Design and Detail Considerations for Galvanizing

## - Bolt hole clearances

- HDG is a coating of zinc over bare steel, so the original steel becomes slightly thicker
  - Could affect bolt hole clearance
  - A 7/8" Dia. bolt hole may need to be oversized
  - A 1" Dia. bolt hole, HDG dia. is same as standard size hole

NOMINAL BOLT DIAMETER ( $d_b$ ) [in]	STANDARD CLEARANCE HOLE DIAMETER [in]	HOLE DIAMETER FOR MINIMIZING REAMING AFTER HDG [in]	MAXIMUM CLEARANCE HOLE DIAMETER [in]
1/4	5/16	3/8	3/8
1/2	9/16	5/8	5/8
5/8	11/16	3/4	13/16
3/4	13/16	7/8	15/16
7/8	15/16	1	1-1/16
1	1-1/8	1-1/8	1-1/4
$d_b \geq 1-1/8$	$d_b + 1/8$	$d_b + 1/8$	$d_b + 5/16$

TABLE 8: CLEARANCE HOLE GUIDELINES

Image credit: AGA

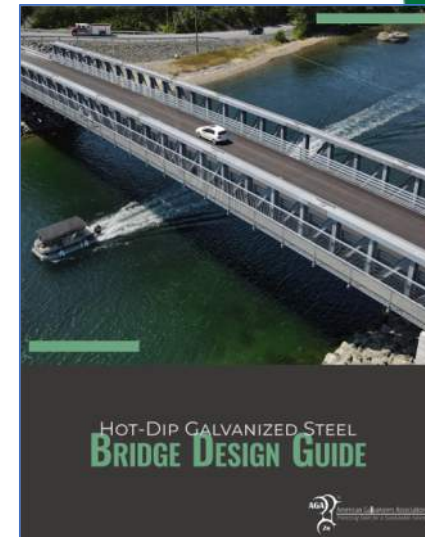

# Design and Detail Considerations for Galvanizing

- Venting and Drainage for HDG
  - Clipped corners of stiffener plates are required

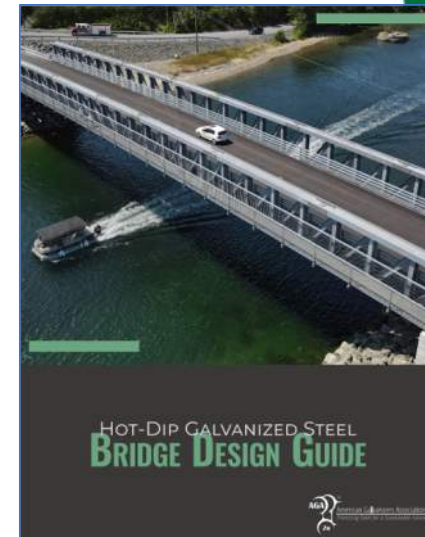

# Design and Detail Considerations for Galvanizing

- **Venting and Drainage for HDG**
  - Cross-frames welded to gussets overlap
  - Given typical thickness, area of overlap, and weld holdback
    - Weld blowout issues are typically prevented
    - Contact AGA as needed

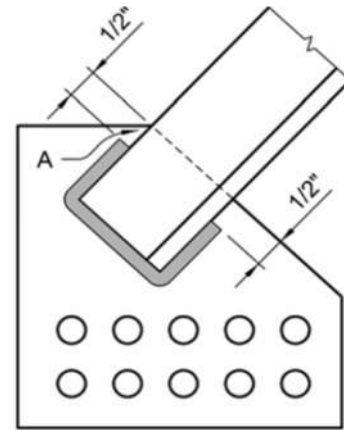
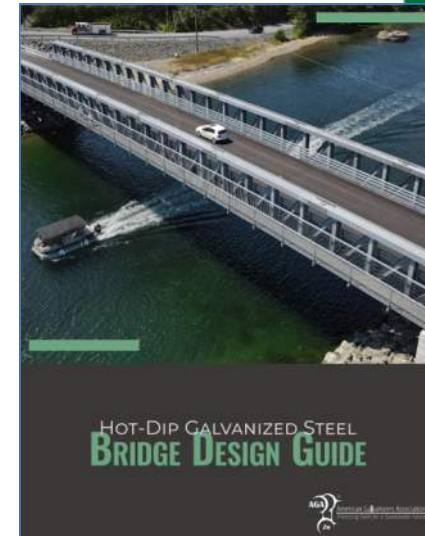

FIGURE 10: EXAMPLE BRIDGE CROSS FRAME DESIGN WITH WELD HOLDBACKS CORNERS

Image credit: AGA



# Steel Bridge Protection Design Strategies

- **Summary:**
- **Make good design decisions early!**
- **Important Resources:**
  - **NSBA Uncoated Weathering Steel Reference Guide**
  - **AGA Hot-Dip Galvanized Steel Bridge Design Guide**
- **Contact the industry with questions!**
  - **NSBA, AGA, SSSBA, Fabricators, Galvanizers**
- **ALWAYS use good detailing practices – ALWAYS!!!**

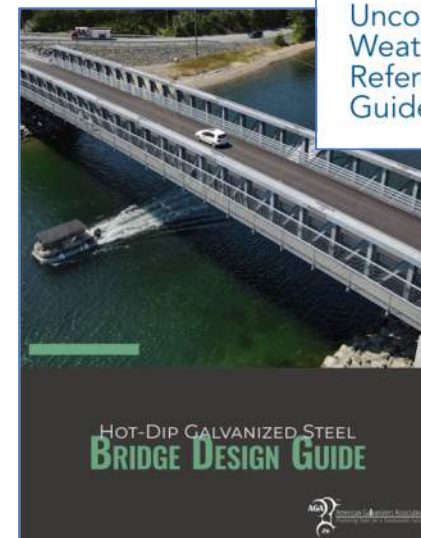
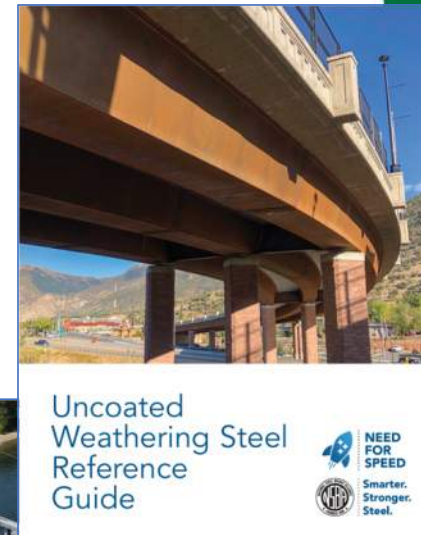

# Steel Bridge Protection Design Strategies

---

Brandon Chavel  
Vice President - Bridges  
American Institute of Steel Construction /  
National Steel Bridge Alliance  
E-mail: [chavel@aisc.org](mailto:chavel@aisc.org)  
Phone: 312.805.2137





# Steel Bridges: Beyond the Textbook

---

## Webinar 5 – Part 1: Steel Bridge Corrosion Protection Design Strategies – A Designer’s Perspective

June 23, 2026

Brandon Chavel, PhD, PE  
National Steel Bridge Alliance

